

# TOSHIBA

INSTALLATION MANUAL  
MANUEL D'INSTALLATION  
INSTALLATIONS-HANDBUCH  
MANUALE DI INSTALLAZIONE  
MANUAL DE INSTALACIÓN  
MANUAL DE INSTALAÇÃO  
INSTALLATIEHANDLEIDING  
ΕΓΧΕΙΡΙΔΙΟ ΕΓΚΑΤΑΣΤΑΣΗΣ

BRANCH PIPE KIT  
KIT DE TUYAU DE BRANCHEMENT  
AUSRÜSTUNG FÜR DIE ZWEIFLEITUNG  
KIT DEI TUBI DI RACCORDO  
JUEGO DE TUBOS DE BIFURCACIÓN  
KIT DE TUBOS DE RAMAL  
ΑΦΤΑΚΡΙΠΣΕΤ  
ΚΙΤ ΣΩΛΗΝΑ ΔΙΑΚΛΑΔΩΣΗΣ

Model/Modèle/Geräte/Modello/Modelo/Modelo/Model/Μοντέλο

## RBC-TWP30E2 RBC-TWP50E2



Please read this Installation Manual carefully before installing the Air Conditioner.

- This Manual describes the installation method of the indoor unit.
- For installation of the outdoor unit, follow the Installation Manual attached to the outdoor unit.

Veillez lire attentivement ce Manuel d'installation avant d'installer le climatiseur.

- Ce manuel décrit la procédure d'installation de l'unité intérieure.
- Pour installer l'unité extérieure, reportez-vous au Manuel d'installation fourni avec l'unité extérieure.

Bitte lesen Sie dieses Handbuch sorgfältig, bevor Sie mit der Installation des Klimagerätes beginnen.

- In diesem Handbuch wird die Installation der Raumeinheit beschrieben.
- Um die Außeneinheit zu installieren, folgen Sie den Anweisungen in dem Handbuch, das der Außeneinheit beiliegt.

Prima di installare il condizionatore d'aria, leggere con attenzione questo manuale d'installazione.

- Questo manuale descrive il metodo d'installazione dell'unità interna.
- Per l'installazione dell'unità esterna, fare riferimento al manuale d'installazione fornito insieme all'unità esterna.

Lea atentamente este Manual de instalación antes de proceder a la instalación del aparato de aire acondicionado.

- Este manual describe el método de instalación de la unidad interior.
- Para la instalación de la unidad exterior, consulte el Manual de instalación que acompaña a la unidad exterior.

Leia atentamente o presente Manual de Instalação antes de instalar o sistema de ar condicionado.

- O presente manual descreve o método de instalar a unidade interior.
- Para a instalação de uma unidade exterior, siga o Manual de Instalação que acompanha a unidade exterior.

Lees deze installatiehandleiding zorgvuldig door voordat u de airconditioner gaat installeren.

- Deze handleiding beschrijft de installatiemethode van de binneneenheid.
- Zie voor de installatie van de buitenunit, de installatiehandleiding bij de buitenunit.

Παρακάτω διαβάστε προσεκτικά το Εγχειρίδιο Εγκατάστασης πριν από την εγκατάσταση του Κλιματιστικού.

- Το παρόν Εγχειρίδιο περιγράφει τη μέθοδο εγκατάστασης της εσωτερικής μονάδας.
- Για την εγκατάσταση της εξωτερικής μονάδας, ακολουθήστε το Εγχειρίδιο Εγκατάστασης που συνοδεύει την εξωτερική μονάδα.

### **ADOPTION OF NEW REFRIGERANT**

This Air Conditioner is a new type which adopts a new refrigerant HFC (R410A) instead of the conventional refrigerant R22 in order to prevent destruction of the ozone layer.

---

### **UTILISATION DU NOUVEAU REFRIGERANT**

Ce climatiseur est d'un type inédit qui utilise le nouveau réfrigérant HFC (R410A) au lieu du réfrigérant traditionnel R22, afin d'éviter la destruction de la couche d'ozone.

---

### **EINFÜHRUNG EINES NEUEN KÜHLMITTELS**

Dies ist ein neuartiges Klimagerät. Anstatt des herkömmlichen Kühlmittels R22 verwendet es das neue ozonschichtschonende HFC Kühlmittel R410A.

---

### **ADOZIONE DI UN NUOVO REFRIGERANTE**

Questo condizionatore d'aria è di un tipo nuovo che adotta un nuovo refrigerante HFC (R410A) al posto del refrigerante convenzionale R22, per prevenire la distruzione dello strato di ozono dell'atmosfera terrestre.

---

### **ADOPCIÓN DE NUEVO REFRIGERANTE**

Este aparato de aire acondicionado es un modelo reciente que incorpora el nuevo refrigerante HFC (R410A) en lugar del refrigerante convencional R22 para así evitar daños en la capa de ozono.

---

### **ADOPÇÃO DO NOVO REFRIGERANTE**

Este sistema de ar condicionado é um modelo novo que adopta um novo refrigerante HFC (R410A) em vez do refrigerante convencional R22 para evitar a destruição da camada de ozono.

---

### **TOEPASSING VAN EEN NIEUW KOELMIDDEL**

Deze airconditioner is een nieuwe type dat werkt met een nieuw koelmiddel HFC (R410A) in plaats van met het conventionele koelmiddel R22, om de aantasting van de ozonlaag te reduceren.

---

### **ΥΙΟΘΕΤΗΣΗ ΝΕΟΥ ΨΥΚΤΙΚΟΥ**

Το παρόν Κλιματιστικό είναι νέος τύπος που υιοθετεί νέο ψυκτικό HFC (R410A) στη θέση του συμβατικού ψυκτικού R22 προκειμένου να βοηθήσει στην προστασία του όζοντος.

## CONTENTS

<b>1</b> PRECAUTIONS FOR SAFETY .....	1	<b>5</b> PIPING THERMAL INSULATION .....	10
<b>2</b> COMPONENT .....	2	<b>6</b> TEST RUN .....	10
<b>3</b> REFRIGERANT PIPING .....	3	<b>7</b> DELIVERY TO CUSTOMER .....	10
<b>4</b> WIRING .....	5		

## SOMMAIRE

<b>1</b> PRECAUTIONS DE SECURITE .....	11	<b>5</b> ISOLATION THERMIQUE DE TUYAUTERIE .....	20
<b>2</b> COMPOSANTS .....	12	<b>6</b> ESSAI DE FONCTIONNEMENT .....	20
<b>3</b> TUYAUTERIE DE FLUIDE FRIGORIGENE .....	13	<b>7</b> LIVRAISON AU CLIENT .....	20
<b>4</b> CABLAGE .....	15		

## INHALT

<b>1</b> SICHERHEITSMASSNAHMEN .....	21	<b>5</b> ANWEISUNGEN ZUR WÄRMEDÄMMUNG IM ROHRSYSTEM .....	30
<b>2</b> KOMPONENTEN .....	22	<b>6</b> TESTLAUF .....	30
<b>3</b> KÜHLMITTELROHRSYSTEM .....	23	<b>7</b> LIEFERUNG AN DEN KUNDEN .....	30
<b>4</b> VERKABELUNG .....	25		

## INDICE

<b>1</b> PRECAUZIONI PER LA SICUREZZA .....	31	<b>5</b> ISOLAMENTO TERMICO DELLE TUBAZIONI .....	40
<b>2</b> COMPONENTE .....	32	<b>6</b> ACCENSIONE DI PROVA .....	40
<b>3</b> TUBAZIONE PER IL REFRIGERANTE .....	33	<b>7</b> CONSEGNA AL CLIENTE .....	40
<b>4</b> CABLAGGI .....	35		

## CONTENIDO

<b>1</b> PRECAUCIONES PARA SEGURIDAD .....	41	<b>5</b> AISLAMIENTO TÉRMICO DE LAS TUBERÍAS .....	50
<b>2</b> COMPONENTE .....	42	<b>6</b> PRUEBA DE FUNCIONAMIENTO .....	50
<b>3</b> TUBERÍAS DE REFRIGERANTE .....	43	<b>7</b> ENTREGA AL CLIENTE .....	50
<b>4</b> CABLEADO .....	45		

## ÍNDICE

<b>1</b> PRECAUÇÕES DE SEGURANÇA .....	51	<b>5</b> ISOLAMENTO TÉRMICO DOS TUBOS .....	60
<b>2</b> COMPONENTE .....	52	<b>6</b> TESTE .....	60
<b>3</b> TUBAGEM DO REFRIGERANTE .....	53	<b>7</b> ENTREGA AO CLIENTE .....	60
<b>4</b> INSTALAÇÃO ELÉCTRICA .....	55		

## INHOUD

<b>1</b> VEILIGHEIDSVORSCHRIFTEN .....	61	<b>5</b> THERMISCHE ISOLATIE VAN DE LEIDINGEN .....	70
<b>2</b> COMPONENTEN .....	62	<b>6</b> WERKINGSTEST .....	70
<b>3</b> KOELLEIDING .....	63	<b>7</b> AFLEVERING AAN DE KLANT .....	70
<b>4</b> BEDRADING .....	65		

## ΠΕΡΙΕΧΟΜΕΝΑ

<b>1</b> ΠΡΟΦΥΛΑΞΕΙΣ ΓΙΑ ΤΗΝ ΑΣΦΑΛΕΙΑ .....	71	<b>5</b> ΘΕΡΜΙΚΗ ΜΟΝΩΣΗ ΣΩΛΗΝΩΣΕΩΝ .....	80
<b>2</b> ΕΞΑΡΤΗΜΑΤΑ .....	72	<b>6</b> ΔΟΚΙΜΑΣΤΙΚΗ ΛΕΙΤΟΥΡΓΙΑ .....	80
<b>3</b> ΣΩΛΗΝΩΣΕΙΣ ΨΥΚΤΙΚΟΥ .....	73	<b>7</b> ΠΑΡΑΔΟΣΗ ΣΤΟΝ ΠΕΛΑΤΗ .....	80
<b>4</b> ΚΑΛΩΔΙΩΣΕΙΣ .....	75		

# 1 PRECAUTIONS FOR SAFETY

The two indoor units of TOSHIBA simultaneous twin packaged air conditioning system are the same units. Set and install the main and sub units taking the installation site into consideration. (Be certain to use the new refrigerant R410A in the indoor units.) The indoor unit connected to the remote controller switch will be the main unit.

- Ensure that all Local, National and International regulations are satisfied.
- Read indoor, outdoor installation manual and this manual carefully before Installation.
- The precautions described below include the important items regarding safety. Observe them without fail.
- After the installation work, perform a trial operation to check for any problem.
- Follow the Owner's Manual to explain how to use and maintain the unit to the customer.
- Turn off the main power supply switch (or breaker) before the unit maintenance.
- Ask the customer to keep the Installation Manual together with the Owner's Manual.

## CAUTION

### New Refrigerant Air conditioner Installation

- **THIS AIR CONDITIONER ADOPTS THE NEW HFC REFRIGERANT (R410A) WHICH DOES NOT DESTROY OZONE LAYER.**
- The characteristics of R410A refrigerant are; easy to absorb water, oxidizing membrane or oil, and its pressure is approx. 1.6 times higher than that of refrigerant R22. Accompanied with the new refrigerant, refrigerating oil has also been changed. Therefore, during installation work, be sure that water, dust, former refrigerant, or refrigerating oil does not enter the refrigerating cycle.
- To prevent charging an incorrect refrigerant and refrigerating oil, the sizes of connecting sections of charging port of the main unit and installation tools are changed from those for the conventional refrigerant.
- Accordingly the exclusive tools are required for the new refrigerant. (R410A)
- For connecting pipes, use new and clean piping designed for R410A, and please care so that water or dust does not enter. Moreover, do not use the existing piping because there are problems with pressure-resistance force and impurity in it.
- The two indoor units of TOSHIBA simultaneous twin packaged air conditioning system are the same units.
- Set and install the main and sub units taking the installation site into consideration.  
(Be certain to use the new refrigerant R410A in the indoor units.)  
The indoor unit connected to the remote controller switch will be the main unit.

## CAUTION

### Wiring

- **TO DISCONNECT THE APPLIANCE FROM MAIN POWER SUPPLY**
- This appliance must be connected to the main supply by means of a switch with a contact separation of at least 3mm.
- The remote controller switch cannot be connected to both of the two indoor units (main and sub units).  
Connect it only to the indoor unit that will become the main indoor unit (Unit A). Connecting the remote controller switch to the sub indoor unit will cause malfunction.

## CAUTION

### Refrigerant Piping (Branch piping system is used for refrigerant piping)



- Compared with R22, pressure of R410A is about 1.6 times. Unless the piping is installed correctly, gas leak may be caused during operation such as pressure boosting. Conduct a leak test of the pipe connecting parts correctly.
- In case the actual length of the piping exceeds the standard piping length, accurately add the refrigerant referring to Additional Refrigerant Amount.
- Thermal insulation materials for the branch pipes are not supplied as accessories. Provide thermal insulation correctly using fitting covers or other materials sold on the market. For further information, read Refrigerant Piping and Piping Thermal Instruction on this manual.  
Improper thermal insulation work will result in a failure and a claim.

### ⚠ WARNING

- **Ask an authorized dealer or qualified installation professional to install/maintain the air conditioner.**  
Inappropriate installation may result in water leakage, electric shock or fire.
- **Turn off the main power supply switch or breaker before attempting any electrical work.**  
Make sure all power switches are off. Failure to do so may cause electric shock.
- **Connect the connecting cable correctly.**  
If the connecting cable is connected in a wrong way, electric parts may be damaged.
- **When moving the air conditioner for the installation into another place, be very careful not to enter any gaseous matter other than the specified refrigerant into the refrigeration cycle.**  
If air or any other gas is mixed in the refrigerant, the gas pressure in the refrigeration cycle becomes abnormally high and it resultantly causes pipe burst and injuries on persons.
- **Do not modify this unit by removing any of the safety guards or by by-passing any of the safety interlock switches.**
- **Exposure of unit to water or other moisture before installation may cause a short-circuit of electrical parts.**  
Do not store it in a wet basement or expose to rain or water.
- **After unpacking the units, examine them carefully if there are possible damage.**
- **Do not install in a place that might increase the vibration of the unit.**
- **To avoid personal injury (with sharp edges), be careful when handling parts.**
- **Perform installation work properly according to the Installation Manual.**  
Inappropriate installation may result in water leakage, electric shock or fire.
- **When the air conditioner is installed in a small room, provide appropriate measures to ensure that the concentration of refrigerant leakage occur in the room does not exceed the critical level.**
- **Install the air conditioner securely in a location where the base can sustain the weight adequately.**
- **Perform the specified installation work to guard against an earthquake.**
- **If the air conditioner is not installed appropriately, accidents may occur due to the falling unit.**
- **If refrigerant gas has leaked during the installation work, ventilate the room immediately.**  
If the leaked refrigerant gas comes in contact with fire, noxious gas may generate.
- **After the installation work, confirm that refrigerant gas does not leak.**  
If refrigerant gas leaks into the room and flows near a fire source, such as a cooking range, noxious gas might generate.
- **Electrical work must be performed by a qualified electrician in accordance with the Installation Manual. Make sure the air conditioner uses an exclusive power supply.**  
An insufficient power supply capacity or inappropriate installation may cause fire.
- **Use the specified cables for wiring connect the terminals securely fix. To prevent external forces applied to the terminals from affecting the terminals.**
- **Conform to the regulations of the local electric company when wiring the power supply.**  
Inappropriate grounding may cause electric shock.
- **Do not install the air conditioner in a location subject to a risk of exposure to a combustible gas.**  
If a combustible gas leaks, and stays around the unit, a fire may occur.

## 2 COMPONENT

The following parts are supplied as accessories of the branch pipes. Check them when opening the carton box.

Part		Quantity	Shape	Use
Installation Instructions		1	This booklet	For installation works
Branch pipe	Gas side	1		For refrigerant pipe branching and collection
	Liquid side	1		
Noise filter		2		For connection on the P.C. board

# 3 REFRIGERANT PIPING

## Tolerance of pipe length and pipe head

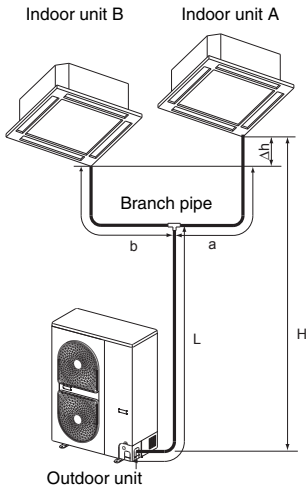

Model (RAV-)	Pipe Length (One Direction)			Height Difference			Remarks
	Full length $L + a$ or $L + b$	Branch piping $a, b$	Difference of branch piping length $b - a$ , or $a - b$	Outdoor Unit - Indoor Unit H		Between Indoor Units $\Delta h$	
				Outdoor Unit Installed Above Indoor Unit	Outdoor Unit Installed Below Indoor Unit		
110*AT 140*AT 160*AT	Below 50 m (actual length)	Below 15 m (actual length)	Below 10 m	Below 30 m	Below 30 m	Below 0.5 m	Less than 10 bends

### CAUTION

Ensure that the shortest pipe length complies with the following:

$$L + b \geq 5 \text{ m}$$

$$a \geq b$$

### CAUTION

When planning a layout for Units A and B, comply with the following:

1. The lengths after branching ("a" and "b") should be equal if feasible. Install Units A and B so that the difference of the branching lengths becomes less than 10m if the lengths cannot be equal due to the branch pipe position.
2. Install Units A and B on the same level. If Units A and B cannot be installed on the same level, the difference in level should be limited to 0.5 m or less.
3. Be certain to install Units A and B in the same room. Units A and B cannot be operated independently each other.

## Piping materials and sizes

Use copper tube of Copper and copper alloy seamless pipes and tubes, with 40 mg/10 m or less in the amount of oil stuck on inner walls of pipe and 0.8 mm in pipe wall thickness for diameters 6.4, 9.5 and 12.7 mm and 1.0 mm, for diameter 15.9 mm. Never use pipes of thin wall thickness such as 0.7 mm.

In parentheses ( ) are wall thickness

Model (RAV -)		110*AT	140*AT, 160*AT
Pipe side	Gas side	Main piping	Ø15.9 (1.0)
		Branch piping	Ø12.7 (0.8)      Ø15.9 (1.0)
	Liquid side	Main piping	Ø9.5 (0.8)
		Branch piping	Ø6.4 (0.8)      Ø9.5 (0.8)

## Branch pipe

Now the refrigerant pipe is installed using branch pipes supplied as accessories.

- Bend and adjust the refrigerant piping so that the branch pipes and pipe after branching become horizontal.
- Fix the branch pipes onto a wall in a ceiling or onto a column.
- Provide a straight pipe longer than 500 mm in length as the main piping of the branches.

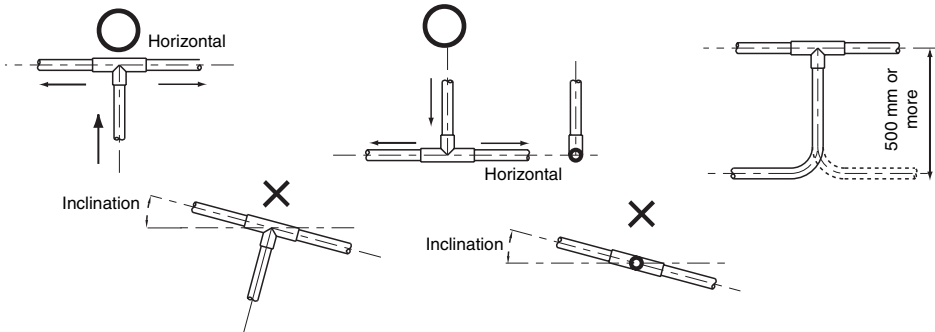

## Air Purging

For the complete information, read the installation instructions for outdoor units of air conditioner.

## Additional Refrigerant Amount

<Formula for Calculating Additional Refrigerant Amount>

Do not remove the refrigerant even if the additional refrigerant amount becomes minus result as a result of calculations by the following formula and operate the air conditioner as it is.

$$\begin{aligned} \text{Additional refrigerant amount (kg)} &= \text{Main piping additional refrigerant amount (kg)} + \text{Branch piping additional refrigerant amount (kg)} \\ &= A \times (L - 18) + B \times (a + b - 4) \end{aligned}$$

- A: Additional refrigerant amount per meter of actual main piping length (kg)  
 B: Additional refrigerant amount per meter of actual branch piping length (kg)  
 L: Actual length of main piping (m)  
 a, b: Actual length of branch piping (m)

	Standard piping length		Additional refrigerant amount per Meter (kg/m)	
	Main piping	Branch piping	A	B
110*AT	18m	2m	0.040	0.020
140*AT 160*AT	18m	2m	0.040	0.040

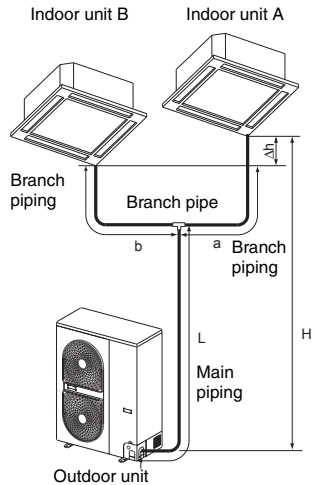

## CAUTION

1. Be certain to write the additional refrigerant amount, pipe length (actual length), head and other specification on the nameplate put on the outdoor unit for recording.
2. Seal the correct amount of additional refrigerant in the system.

## Gas Leak Test

- Use a leak detector manufactured specially for the HFC refrigerant (R410A, R134a, etc.) when testing R410A. The sensitivity of leak detectors for previous HCFC refrigerants (such as R22) lowers to about 1/40 when used with HFC refrigerants and these detectors cannot be used.

# 4 WIRING

1. **Using the specified cables, ensure to connect the wires, and fix wires securely so that the external tension to the cables do not affect the connecting part of the terminals.**

Incomplete connection or fixation may cause a fire, etc.

Be certain to install wires by connecting them to terminals of the same numbers according to the following wiring diagram.

2. **Be sure to connect earth wire. (Grounding work)**

Do not connect the earths wire to gas pipe, city water pipe, lightning rod, or the earth wire of telephone.

Incomplete grounding causes an electrical shock.

3. **For electric work, strictly follow the Local Regulation in each country, Indoor, outdoor, and this Installation Manual, and use an exclusive circuit.**

Capacity shortage of power circuit or incomplete installation may cause an electrical shock or a fire.

## Indoor Unit P.C electrical parts

**This work is unnecessary for concealed duct type, under ceiling type and 4-way air discharge cassette type (0 to 3 series).**

This work is necessary for each indoor unit.

1. Disconnect the read wire between remote controller terminal and CN41 (RC) connector on the P.C.board.

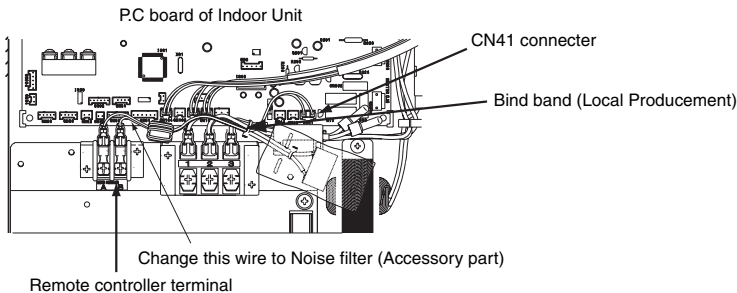

2. Connect the Noise Filter between remote controller terminal and CN41 (RC) connector on the P.C.board.
3. Bind this wire and main terminal wire by bind band.

## Internal And External Connection Wiring

1. Install wires from the outdoor unit to the main unit as in usual wiring.  
(Wires (1), (2), (3) and ground wire.)
2. Install wires (1), (2) and ground wire only when installing connection wires from the master unit to the sub unit.

## Remote Controller wiring

1. Installing connection wires from the master unit to the sub unit.
2. Install jumper wires between the main unit and sub unit. The jumper wires of the remote controller have no polarities. The remote controller circuits are low voltage circuits. These circuits must not be made to directly contact internal and external wires or contained in the same conduit tubes that house internal and external wires.  
(Otherwise malfunction will be caused by noise)



## Wiring Diagram

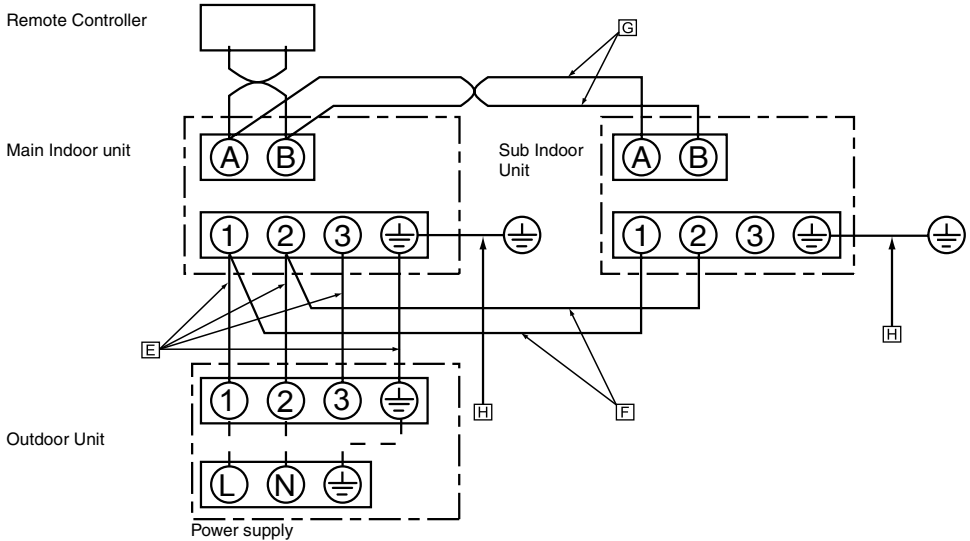

## Wiring Specification

Specification of Wires Between Units and Numbers of Wires.

Outdoor unit - indoor unit (main unit) [E]	No. of wires	4 (Include ground wire)
	Wire diameter	H07RN-F or 245IEC66 1.5 mm <sup>2</sup> or more
Indoor unit (main unit) - indoor unit (sub unit) [F]	No. of wires	2
	Wire diameter	H07RN-F or 245IEC66 1.5 mm <sup>2</sup> or more
Remote controller wiring [G]	No. of wires	2
	Wire diameter	Between 0.5 mm <sup>2</sup> and 2 mm <sup>2</sup> (up to 200 m)
Grounding wire of indoor sub unit [H]		H07RN-F or 245IEC66 1.5 mm <sup>2</sup> or more

Procure necessary parts and perform all connection work locally.

### NOTES

When using the equipment at the first time, it will take a lot of time that the remote controller accepts an operation after power was on. However, it is not a trouble.

#### Automatic address

While automatic addressing, the operation can not be performed on the remote controller.

For automatic addressing, Max. 10 minutes (generally, approx. 5 minutes) are required.

#### When power will be turned on after finish of automatic addressing;

It will require Max. 10 minutes (generally, approx. 3 minutes) that outdoor unit starts operation after power was on.

# When installing the RAV-SM1603AT-E

## Wiring Diagram

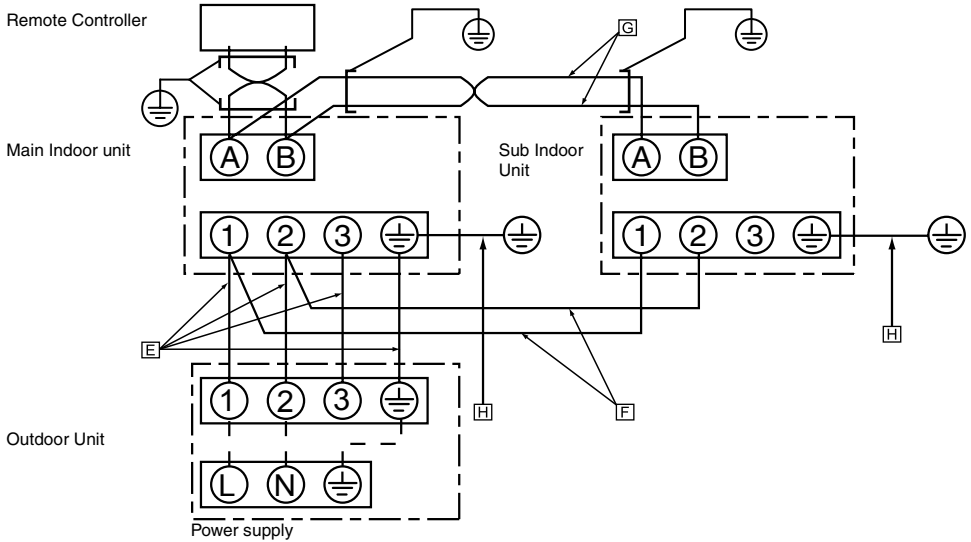

## Wiring Specification

Specification of Wires Between Units and Numbers of Wires.

Outdoor unit - indoor unit (main unit) [E]	No. of wires	4 (Include ground wire)
	Wire diameter	H07RN-F or 245IEC66 1.5 mm <sup>2</sup> or more
Indoor unit (main unit) - indoor unit (sub unit) [F]	No. of wires	2
	Wire diameter	H07RN-F or 245IEC66 1.5 mm <sup>2</sup> or more
Remote controller wiring [G]	No. of wires	2 (Shield wire)
	Wire diameter	Between 0.5 mm <sup>2</sup> and 2 mm <sup>2</sup> (up to 200 m)
Grounding wire of indoor sub unit [H]		H07RN-F or 245IEC66 1.5 mm <sup>2</sup> or more

Procure necessary parts and perform all connection work locally.

## NOTES

When using the equipment at the first time, it will take a lot of time that the remote controller accepts an operation after power was on. However, it is not a trouble.

### Automatic address

While automatic addressing, the operation can not be performed on the remote controller.

For automatic addressing, Max. 10 minutes (generally, approx. 5 minutes) are required.

### When power will be turned on after finish of automatic addressing;

It will require Max. 10 minutes (generally, approx. 3 minutes) that outdoor unit starts operation after power was on.

**WARNING**

For simultaneous twin systems, perform the following to conform to EMC standards.

1. Be sure to use shield wire for remote controller wiring.
2. Connect earth wire independently to each indoor unit.
3. Attach the ferrite core (white) supplied with the outdoor unit to indoor/outdoor connecting wires.
  - Pass indoor/outdoor connecting wires ① and ② through the supplied ferrite core and wind them making a single turn, and then connect them to the terminals of the outdoor unit. Connect the indoor/outdoor connecting wire ③ and the earth wire directly to the outdoor unit terminals.
4. Attach the clamp filter (gray) supplied with the outdoor unit to the outdoor fan motor lead wire.
  - Attach the supplied clamp filter securely to the fan motor lead wire (lower) in the electric parts box of the outdoor unit.

- For how to install the indoor unit, refer to the Installation Manual supplied with the indoor unit.

**1. Attaching the ferrite core**

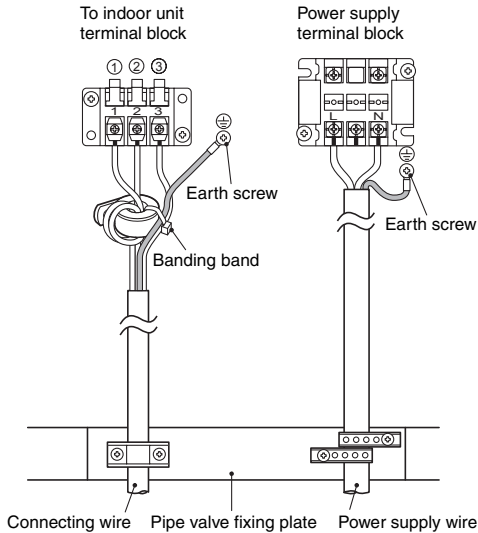

\* Clamp the indoor/outdoor connecting wire ③ and the earth wire together with the ferrite core with the supplied banding band.

**Stripping length power cord and connecting wire**

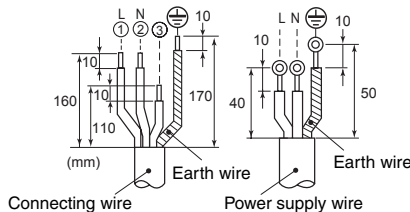

## 2. Attaching the clamp filter

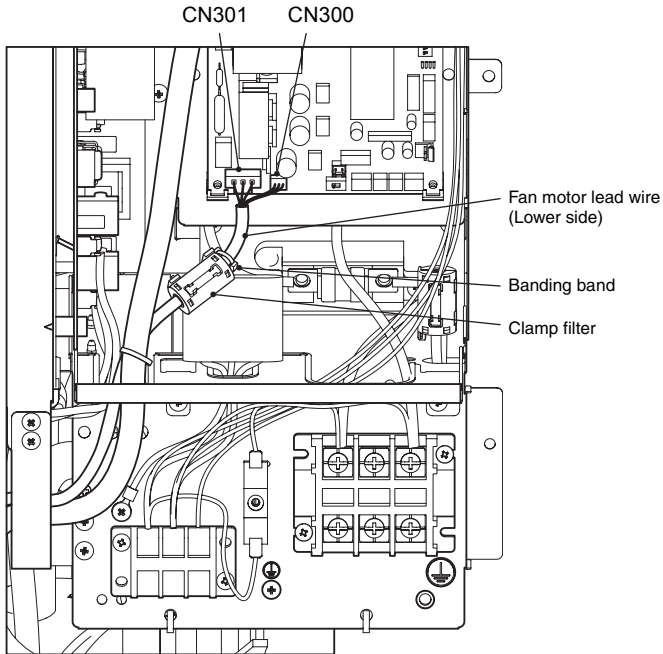

Attach the clamp filter supplied with the outdoor unit to the lower outdoor fan motor lead wire.

- Make sure that the claw of the clamp filter is securely locked.
- Pass the banding band supplied with the outdoor unit through the upper hole of the clamp filter to clamp it together with the fan motor lead wire.
- The fan motor lead wires are connected to the connectors CN301 and CN300 on the P.C. board of the outdoor unit.

# 5 PIPING THERMAL INSULATION

---

## Thermal insulation was produced locally.

Be certain to thermally insulate the piping both on the liquid and gas sides.

- Use thermal insulating materials for piping higher than 120 degree in heat resistance.  
Example: EPT - Ethylene, propylene, terpolymer
- Thermally insulate the branch pipe sections using fitting covers (for tees) more than 10mm in thickness or processing thermal insulation materials as follows.  
(Thermal insulation materials for the branch pipes are not supplied as accessories.)
- Seal the branch pipe sections tightly without producing gaps

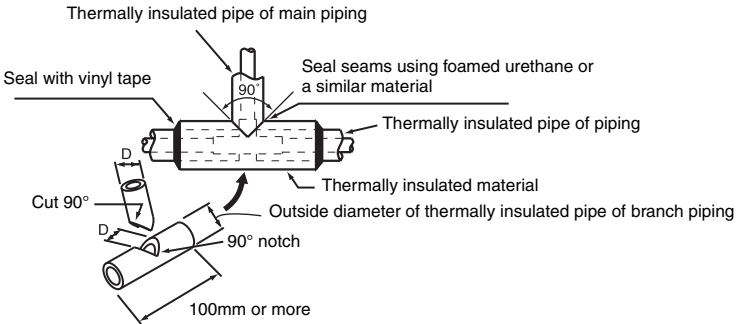

# 6 TEST RUN

---

Be certain to conduct a test run in accordance with the procedures contained in the operating and installation instructions supplied with the indoor units.

# 7 DELIVERY TO CUSTOMER

---

- Make certain to hand over the instruction manual supplied with the indoor units to the customer.
- Deliver the system after thoroughly explaining the contents of the instruction manual.  
It is important to explain to the customer in details about simultaneously starting and stopping the two indoor units by operating one remote controller switch.

