

TOSHIBA

FILE No. A10-2007-1
Revision 1: Oct., 2021

Central Control Device

SERVICE MANUAL

Central Remote Controller

Model name:

TCB-SC640U-E

TCB-SC640U-TR

TCB-SC640U-ME

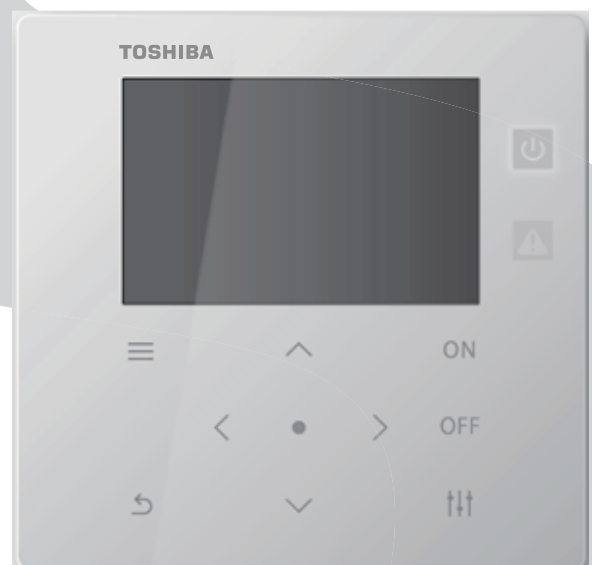





Contents

Safety Precautions	3
1 Product Overview	5
2 System Configuration	8
3 Initial Settings	9
4 Troubleshooting	21
5 Check Code List	26
Installation Manual	27
Owner's Manual	61



Safety Precautions

- This section explains safety precautions you must follow in order to prevent harm to the user and other persons and damage to property.
- "Display Description" explains the classification of the degree of harm or damage that may occur if the unit is handled incorrectly, while "Symbol Description" indicates the meanings of symbols.





Display Description	Symbol Description
 WARNING Indicates "Content that is expected to result in death or serious injury (*1) to the user in the case of incorrect handling".	 ○ indicates prohibited actions. Specifically prohibited contents are indicated with a picture and/or text in or near the symbol.
 CAUTION Indicates "Content that is expected to result in minor injury (*2) to the user or damage to property (*3) in the case of incorrect handling".	 ● indicates instructions which must be followed. The actual contents of the instructions are indicated with a picture and/or text in or near the symbol.

* 1: Serious injury refers to lasting after effects such as blindness, injury, burns (high temperature / low temperature), electric shock, bone fracture, or poisoning, etc. and injuries that require hospitalization/long-term outpatient treatment.
 * 2: Minor injury refers to injuries, burns, or electric shocks, etc. that do not require hospitalization or long-term outpatient treatment.
 * 3: Damage to property refers to extended damage related to houses, household goods, livestock, or pets, etc.

WARNING

- 
Turning off the circuit-breaker
 - **Set the circuit-breaker to "OFF" before starting work**
Failing to do so may result in a high-voltage electric shock, leading to death or injury.
- 
Prohibited
 - **Do not turn on the circuit-breaker when the cover is removed**
Doing so may result in a high-voltage electric shock leading to death or injury.

CAUTION

- 
Check earth connection
 - **Check that the earth wire (*) is connected to the unit earth terminal before beginning troubleshooting and repair work**
If the earth wire is not connected, there is the risk of electric shock in the event of an electric leakage occurring.
- 
Modification prohibited
 - **Do not modify the product**
Also, do not disassemble or modify the parts.
Doing so may cause fire, electric shock, or injury.
- 
Children must be kept away
 - **Only qualified engineers should be allowed on a troubleshooting or repair work site. Children and all other third parties must be kept away**
There is a risk of injury from tools or disassembled parts.
Inform the customer that children and other third parties must be kept away from the work site.
- 
Insulation
 - **After connecting a crimp terminal to a cut lead wire, place the closed-end facing up and clean it**
If connections are not properly processed, electrical leakage, ignition or other accident could occur on the customer's premises.
- 
Wiring Precautions During Assembly
 - **After repairs are complete, be sure to reassemble the disassembled parts and connect and route the wires to restore the equipment to its original state. Make sure internal wires are not trapped in the cabinets, panels, or other parts**
An assembly or wire connection problem may result in a short circuit, ignition or other accident on the customer's premises.



Insulation check

- **After the work is completed, be sure to test between the live and dead metal parts (earth terminal) with an insulation resistance tester (500 V) to confirm that the insulation resistance is 2 MΩ or higher**

A low insulation resistance value may result in a short circuit, electric shock or other accident on the customer's premises.



Risk of electric shock

- **If you have to inspect a circuit that is energized, for example, take precautions such as wearing rubber gloves to avoid direct contact with a live part**

Touching a live part may result in an electric shock.



Check after repair

- **Check that there are no abnormalities after completing the repair work**

Failure to perform this check may result in fire, electric shock, or injury.

Turn off the earth leakage breaker before performing an inspection.

- **After completing the repair work, perform a test run and check that there are no abnormalities such as smoke or unusual noise**

Failure to perform this check may result in fire or electric shock.

Perform a test run after installing the front panel and cabinets.



Repair and reinstallation work

- **Installation and reinstallation work should be performed by your vendor or a qualified electrician**

Attempting to carry out installation work on your own, and doing so incorrectly, may result in electric shock or fire.

1 Product Overview

1-1. Product Specifications

Specifications

Power supply	220-240 V AC 50/60Hz
Consumed current	0.06 A
Operating temperature and humidity ranges	0~40°C 10~90% (no condensation)
Dimensions	H: 120 x W: 120 x D: 20 (+ 50.6) mm
Weight	550 g
Number of connected units	Max. 64 groups (64 units)
LCD	Full-dot liquid crystal with backlights
External output	2 points (Run, Alarm)
External input	3 points (ON,OFF, Emergency system, Night Operation, Locking, Thermo OFF, Power peak cut)

Outline Drawing

(Unit: mm)

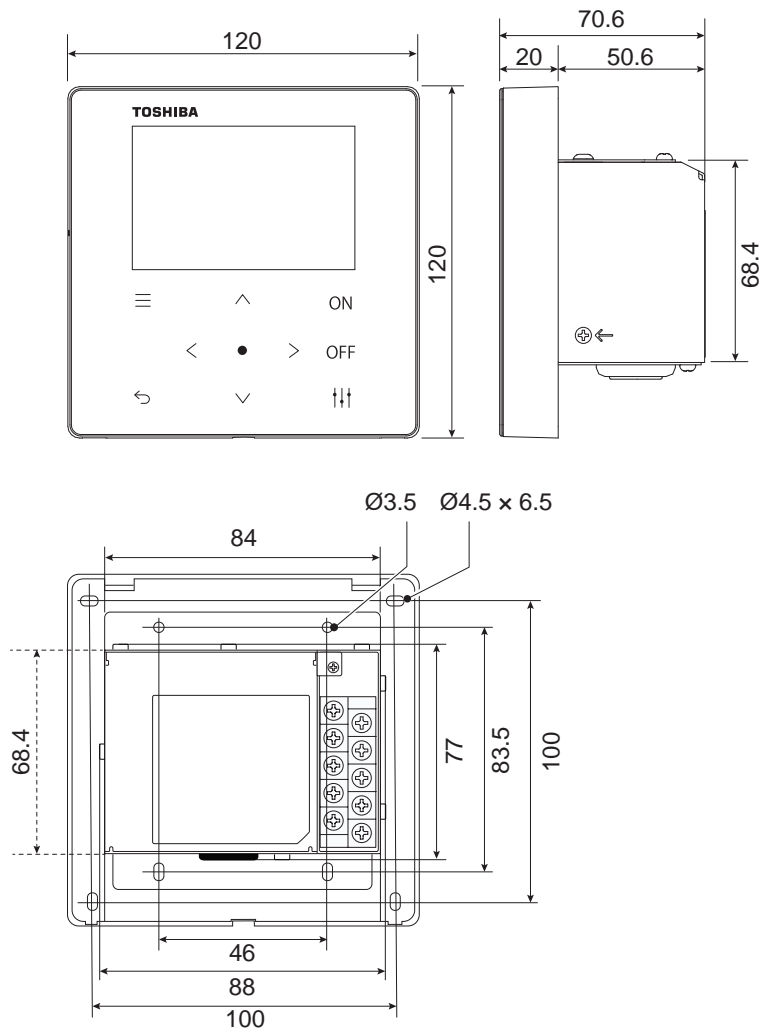

1-2. Air conditioner

1-2-1. Function list

Main functions		
Control	ON/OFF	
	Operation Mode	
	Set temperature	
	Fan speed	
	Louver	
	Key lock	
	Ventilation ON/OFF	
	Ventilation mode	
	Ventilation Fan speed	
	Energy saving operation	
	Filter Sign Reset	
	Monitor	ON/OFF
		Operation Mode
Set temperature		
Fan speed		
Louver		
Key lock		
Ventilation ON/OFF		
Ventilation mode		
Ventilation Fan speed		
Energy saving operation		
Filter Sign		
Check code		
Notice code		

Main functions		
Operating Schedule	Setting target: Zone	
	Setting unit: Day of week	
	Setting range: 6 weeks	
	Special day: 2 options	
	Setting time: 00:00 to 23:59	
	Setting content	ON/OFF
		Set temperature
		Operation mode
		Key lock
	Maximum number of schedules per day: 8	
Energy-saving Schedule	Setting target: Zone	
	Setting unit: Day of week	
	Setting range: 1 weeks	
	Setting time: 00:00 to 23:59	
	Setting content	Save rate
	Maximum number of schedules per day: 8	
External input	Number of points	3
	Functions	ON
		OFF
		Emergency system
		Night Operation
		Locking
		Thermo OFF
		Power peak cut
External output	Number of points	2
	Functions	Run
		Alarm

1-2-2. Monitoring Controls

Refer to the Owner's Manual (P.20 to 23) regarding monitoring controls of air conditioners.

1-2-3. Schedule Functions

Refer to the Owner's Manual (P.24 to 31) for the operating procedure of the schedule functions.

1-3. Air to Water Heat Pump

1-3-1. Function list

Main functions	
Control	ON/OFF
	Operation Mode
	Set temperature
	Key lock
Monitor	ON/OFF
	Operation Mode
	Set temperature
	Key lock
	Check code

Main functions			
Operating Schedule	Setting target: Zone		
	Setting unit: Day of week		
	Setting range: 6 weeks		
	Special day: 2 options		
	Setting time: 00:00 to 23:59		
	Setting content	ON/OFF	
		Set temperature	
		Operation mode	
		Key lock	
	Maximum number of schedules per day: 8		
External input	Number of points	3	
	Functions	ON	
		OFF	
		Emergency system	
		Night Operation	
		Locking	
External output	Number of points	2	
	Functions	Run	
		Alarm	

1-3-2. Monitoring Controls

Refer to the Owner's Manual (P.35 to 38) regarding monitoring controls of air to water heat pump.

1-3-3. Schedule Functions

Refer to the Owner's Manual (P.39 to 46) for the operating procedure of the schedule functions.

2 System Configuration

2-1. Air conditioner only

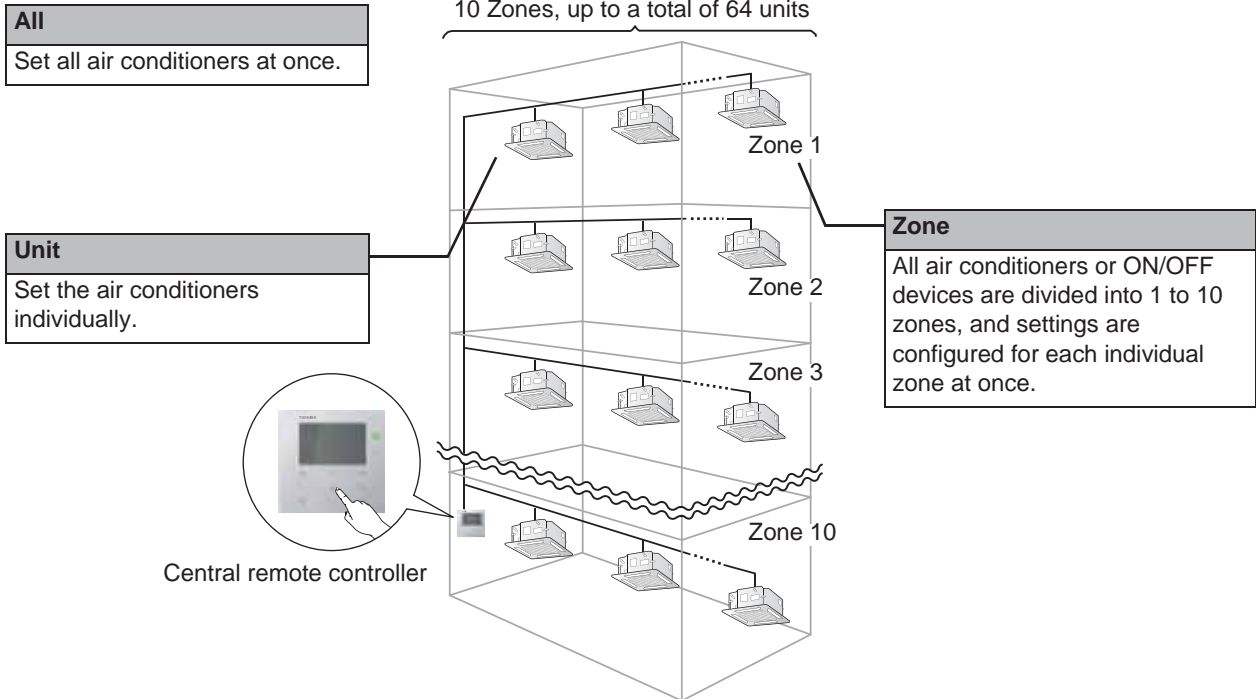

- Control can be exerted in three different units: All, Zone, and Unit.
- Up to 10 zones can be controlled.
- Up to 64 units (air conditioners and ON/OFF devices) can be controlled.
- ON/OFF device: A device whose set temperature and operation mode cannot be controlled or monitored.
The major devices include the light settings, Total Heat exchange unit, and ventilating fan.

2-2. Air conditioner and Air to Water Heat Pump

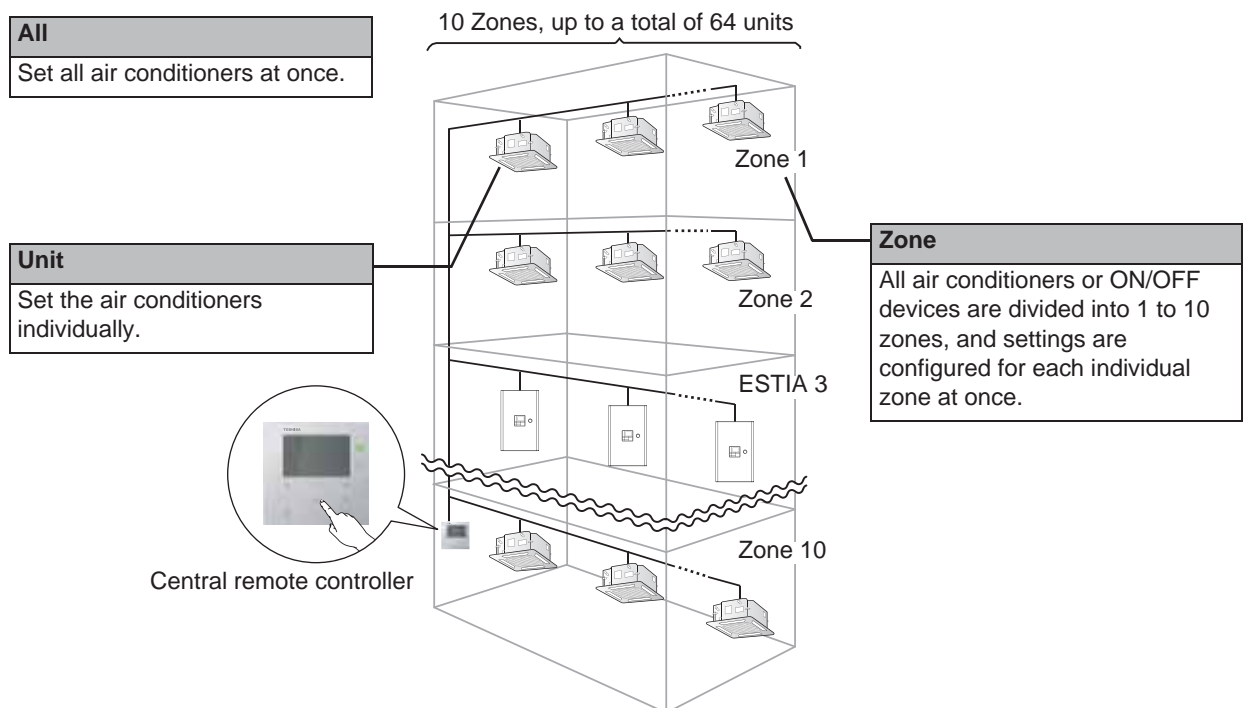

3 Initial Settings

3-1. Installation Work

Setting up the main unit. Refer to the Installation Manual provided with the product for the setup procedures.

3-2. Central Remote Controller Test Run

- Set according to the following procedure before use.
This allows the unit to monitor and operate the air conditioners.

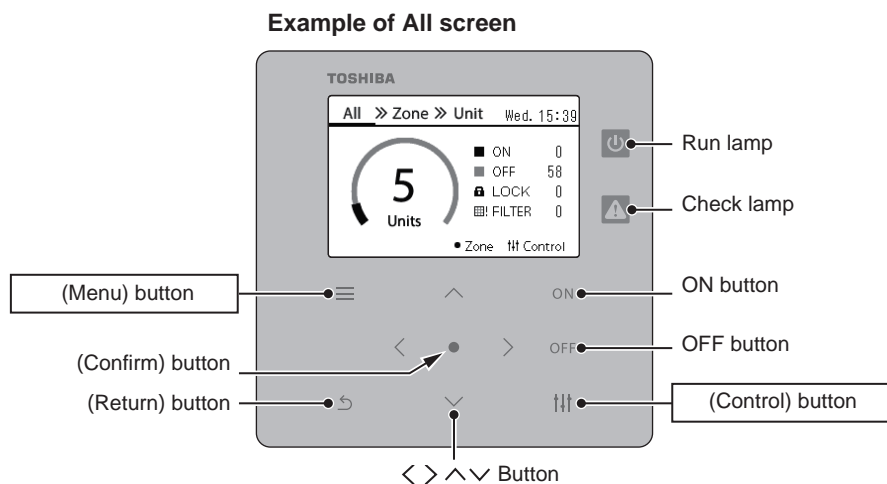

1 Turn on all connected equipment

- Indoor unit, outdoor unit, air to air heat exchanger, general purpose equipment control interface, etc.

2 Turn on the power of the Central Remote Controller

- A Central control address must be assigned to the indoor units to be controlled.
<Preparation for Central control address settings>
- A Central Remote Controller or wired remote control is required to set the Central control address.
- Set the Central control address after finishing the test run of the indoor unit.
- * If you wish to configure the settings with the Central Remote Controller, you must first complete initial communication with all connected indoor units and outdoor units. Wait at least 10 minutes after turning on the power to the air conditioner before configuring the settings.

NOTE

- If you configure the Central control address settings before initial communication with the outdoor units is fully completed, the address may not be set for some units.
- For the TCC-LINK model, perform the following settings.
Connect the U3 and U4 terminals in the outdoor unit (centre unit) to the relay connectors.

3 Register the indoor units to the unit

Press the [≡] and [↑↑] buttons simultaneously for 4 seconds or more on the All screen to move to "How to Display the "Servicing Menu" Screen (P.11-2)". Perform "Obtain Address (If you will not change the Central control address (P.12-1 to 2))" of "Address Settings".

After performing "If you will not change the Central control address (P.12-2)", check that there is no error in the displayed number of connected units, line address-indoor address, and Central control address (*1), then perform "If you will not change the Central control address (P.12-3)".

*1 If there is an error

- Check the power supply and wiring.
- To change the address, use the local remote controller or the unit ("To change the Central control address (P.13-3 to 4)").
- Repeat the setting in this section (3.Register the indoor units to the unit) from the beginning.

4 Assign indoor units to zones 1 to 10

Perform "Change the Zone to which the Indoor Unit Belongs (Zone Settings) (P.15-1 to 4)".

Return to the All screen and check if the displayed number of units matches the number registered in the zone (*2).

*2 Indoor units that are not registered in a zone are not included in the number of units on the All screen.

5 Operation confirmation

Check whether the indoor units can be operated from the Central Remote Controller.

Also, check whether the operation of the local remote controller is reflected on the Central Remote Controller.

6 Preparation for delivery

If an inspection code occurs during operation check, perform "Installation Manual (Delete check history (P.23))".

This completes the test run for the controller.

For other detailed settings, refer to "Owner's Manual" and "Installation Manual (P.16 to 33)".

Example of Obtain Address screen

Line address	Indoor address	Central control address	
Obtain Address (1/2) ↑ Next	001-006	006	001-014 014
	001-007	007	001-015 015
	001-008	008	001-016 016
	001-009	009	001-017 017
	001-010	010	001-018 018
	001-011	011	001-019 019
	001-012	012	001-020 020
	001-013	013	001-021 021

Example of zone setting (Central control Address) screen

Number of units that have been set
Central control address Zone No.

Zone Settings <64> (1/4) ↑ Next			
001	1	000	1
002	1	010	1
003	1	011	3
004	1	012	3
005	2	013	10
006	2	014	10
007	2	015	10
008	2	016	10

3-3. Address Settings

How to Display the "Servicing Menu" Screen

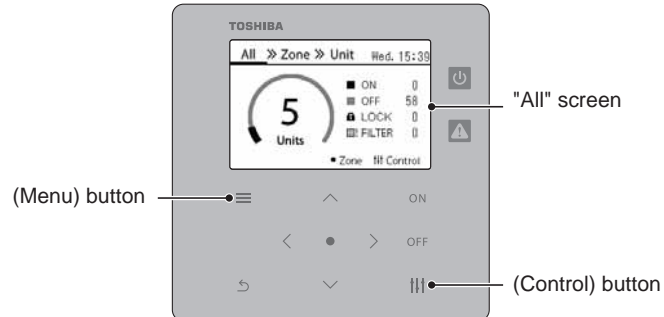

1 Display the "All" screen

2 Press [≡] (Menu) and [|||] (Control) together for more than 4 seconds

The "Servicing Menu" screen appears.

Servicing Menu(1/2)
1. Address Settings
2. Zone Settings
3. Display settings
4. Check/Notice Settings
5. External Input Settings

Servicing Menu(2/2)
6. CRC Mode Change Conf.
7. DN setting
8. Communication Conf.
9. Communication Check
10. Register Contact Info

3 Press [^] and [v] to select the item, then press [●] (Confirm)

Register/Check Indoor Unit (Address Settings)

Address Settings
1. Obtain Address
2. Address Display
3. Address Auto-setting

1 Select "Address Settings" on the "Servicing Menu" screen and press [●] (Confirm)

The "Address Settings" screen appears.

2 Press [^] and [v] to select the item, then press [●] (Confirm)

The screen of the selected item appears.

Obtain Address

Register the indoor unit to the unit.

◆ If you will not change the Central control address

Set the Central control address with the local remote controller in advance.

If you will change the Central control address with the central controller, see "To change the Central control address (P.13)".

Obtain Address
Obtain the address?
Yes
No

1 Select "Obtain Address" on the "Address Setting" screen and press [●] (Confirm)

The "Obtain Address" confirmation screen appears.

2 Press [^] and [v] to select "Yes", then press [●] (Confirm)

"Obtaining address... ⌚" appears, and after a while, the "Indoor unit list" screen appears.

- This operation will take several minutes.
- On the "Obtain Address" confirmation screen, press [↵] (Return) or select "No" and press [●] (Confirm) to return to the "Address Settings" screen.

Indoor unit list screen

Obtain Address	(1/2)	tit	Next
001-006	006	001-014	014
001-007	007	001-015	015
001-008	008	001-016	016
001-009	009	001-017	017
001-010	010	001-018	018
001-011	011	001-019	019
001-012	012	001-020	020
001-013	013	001-021	021

3 On the "Indoor unit list" screen, check that there is no error in the number of connected units and the displayed address, then press [↵] (Return)

The "Address Confirm" confirmation screen appears.

- Press [^] and [v] or [↑↓] (Control) to switch pages.

Obtain Address	(1/2)	tit	Next
Confirm			
this address?			
Yes			
No			
001-012	012	001-020	020
001-013	013	001-021	021

4 Press [^] and [v] to select "Yes", then press [●] (Confirm)

After the "Address Settings ⌚" screen, return to the "Servicing Menu" screen.

This completes "Obtain Address".

- Select "No" and press [●] (Confirm) to return to the "Servicing Menu" screen without registering indoor units.

◆ To change the Central control address

Address Settings
1. Obtain Address
2. Address Display
3. Address Auto-setting

Obtain Address
Obtain the address?
Yes
No

1 Select "Obtain Address" on the "Address Settings" screen and press [●] (Confirm)

The "Obtain Address" confirmation screen appears.

2 Press [▲] and [▼] to select "Yes", then press [●] (Confirm)

"Obtaining address... ⌚" appears, and after a while, the "Indoor unit list" screen appears.

- This operation will take several minutes.
- On the "Obtain Address" confirmation screen, press [↵] (Return) or select "No" and press [●] (Confirm) to return to the "Address Settings" screen.

Indoor unit list screen

Obtain Address	(1/2)	#	Next
001-006	006	001-014	014
001-007	007	001-015	015
001-008	008	001-016	016
001-009	009	001-017	017
001-010	010	001-018	018
001-011	011	001-019	019
001-012	012	001-020	020
001-013	013	001-021	021

3 Press [◀] [▲] [▼] [▶] to select the indoor unit whose Central control address you want to change, then press [●] (Confirm)

The "Central control address list" screen appears.

- In the screen, black is "cursor" and grey is "assigned Central control address".
- The Central control address can be set within the following range.
Models that support TU2C-LINK: 1 to 128
Models that do not support TU2C-LINK: 1 to 64

Central control address list screen

Obtain Address	(1/2)	#	Next
001-006			
001	002	003	004
009	010	011	012
017	018	019	020
025	026	027	028
029	030	031	032
● Confirm			

4 Press [◀] [▲] [▼] [▶] to select the Central control address, then press [●] (Confirm)

Return to the "Indoor Unit List" screen.

5 After changing the Central control address, press [↵] (Return) on the "Indoor Unit List" screen

The "Address Confirm" confirmation screen appears.

Obtain Address	(1/2)	#	Next
Confirm			
this address?			
Yes			
No			
001-012	012	001-020	020
001-013	013	001-021	021

6 Press [▲] and [▼] to select "Yes", then press [●] (Confirm)

"Registering the address... ⌚" → "Obtaining address... ⌚" appears and the display returns to the "Indoor Unit List" screen.

- This operation will take several minutes.
- Select "No" and press [●] (Confirm) to return to the "Servicing Menu" screen without registering the changed address.

7 Check that the displayed address is the address changed in steps 3 to 4, and press [↵] (Return)

The "Address Confirm" confirmation screen appears.

8 Press [▲] and [▼] to select "Yes", then press [●] (Confirm)

After the "Address Settings ⌚" screen, return to the "Servicing Menu" screen.

This completes "Obtain Address".

- This operation will take several minutes.

When Light commercial is Set for 1 to 28 Lines

When registering a Light commercial that is set for 1 to 28 lines, before doing "Obtain Address", use "Communication Conf." to change the method to obtain indoor unit addresses for Central control address mode.

Servicing Menu(2/2)
6. CRC Mode Change Conf.
7. DN setting
8. Communication Conf.
9. Communication Check
10. Register Contact Info

- 1 In the "Servicing Menu" screen, select "Communication Conf." and then press [●] (Confirm).**

The "Communication Conf." screen is displayed.

Communication Conf.
No 12345678
SW1 00000001
SW2 00000000
SW3 10000000
0:OFF 1:ON

- 2 Press [<] [^] [v], and [>] to put the cursor on SW2-8.**

Communication Conf.
No 12345678
SW1 00000001
SW2 0000000 8
SW3 10000000
0:OFF 1:ON

- 3 Press [Λ] to set a value of 1, and then press [●] (Confirm).**

The data is confirmed, and the "Servicing Menu" screen returns.

- 4 Perform "Obtain Address (◆ If you will not change the Central control address (P.12))".**

About L20 (Duplicated central control addresses) Warnings

"When you connect the Central Control Device, set a central control address (DN03) for each indoor unit. Central control addresses require that you register separate numbers for each indoor unit, but if you mistakenly register the same central control address for different indoor units, an L20 (duplicate central control address) warning will be detected by Central Control Device or the local remote control.

With TU2C-LINK, the Central Control Device detects an L20. With TU2C-LINK, the remote controls belonging to the individual indoor units detect an L20.

The Central Control Device, which is incompatible with TU2C-LINK, may not be able to detect an L20, depending on conditions*, if the indoor unit is compatible with TU2C-LINK. Be sure to do a one-to-one test for the Central Control Device and indoor units. There are some models on which you can check for duplications on the central control address list screen, depending on the model of the Central Control Device."

*Conditions: When the same central control address is set for indoor units using different coolant systems in a system of outdoor units and indoor units that are compatible with TU2C-LINK and a Central Control Device that is incompatible with TU2C-LINK.

3-4. Zone Settings

Change the Zone to which the Indoor Unit Belongs (Zone Settings)

Zone Settings
1. Central control Address
2. Line Address
3. Delete zone setting

1 On the "Servicing Menu" screen, select "Zone Settings" and press [●] (Confirm)

The "Zone Settings" screen appears.

- The indoor unit list display can be selected from the Central control address order or the Lineage Address order.

◆ When Central control Address is selected 2 Select "Central control Address" using [^] and [v] then press [●] (Confirm)

Zone Settings <64> (1/4) # Next			
001	1	009	1
002	1	010	1
003	1	011	3
004	1	012	3
005	2	013	10
006	2	014	10
007	2	015	10
008	2	016	10

The "Address list" screen appears.

- Press [↑↓] (Control) to go to the next page.

3 Press [<] [^] [v] [>] to select the address, then press [●] (Confirm)

The "Zone list" screen appears.

Zone Settings <64> (1/4) # Next			
001	1	009	1
002	1	010	1
003	1	011	3
004	1	012	3
005	2	013	10
006	2	014	10
007	2	015	10
008	2	016	10

4 Press [<] [^] [v] [>] to select a zone No., then press [●] (Confirm)

The display returns to the "Address List" screen.

- The selected zone No. appears to the right of the address.
- The number inside < > is the number of units for which the zone No. is set.
- Up to 64 units can be set.
- Air conditioners and Air to Water Heat Pump cannot be set in the same zone.
- If there is both a water temperature control unit and a room temperature control unit, set them in different zones.
If they are set in the same zone, it will not be possible to apply batch settings by zone or to set the temperature based on a schedule.

To Change the Group Zone of Multiple Indoor Units

◆ When "Central control Address" is selected

Zone Settings <64> (1/8) †† Next			
001	1	009	2
002	1	010	2
003	1	011	2
004	1	012	2
005	1	013	2
006	1	014	2
007	1	015	2
008	1	016	2

1 Perform steps 1 to 2 in "Change the Zone to which the Indoor Unit Belongs (Zone Settings) (P.15)".

The "Address List" screen is displayed.

- You can set either "Central control Address" or "Line Address".

2 Put the cursor on the first address, and then press [≡] (Menu) and [●] (Confirm) at the same time.

Multiple units are selected.

- If you press [↵] (Return), the selection of multiple units is cancelled, and the cursor returns to the first address.

Zone Settings <64> (1/8) †† Next			
001	1	009	2
002	1	010	2
003	1	011	2
004	1	012	2
005	1	013	2
006	1	014	2
007	1	015	2
008	1	016	2

001 ~ 009

1	2	3	4	5
6	7	8	9	10

Del ● Confirm

3 Select the last address by using [<], [^], [v], and [>], and then press [●] (Confirm).

The "Zone List" screen is displayed.

Zone Settings <64> (1/8) †† Next			
001	5	009	5
002	5	010	2
003	5	011	2
004	5	012	2
005	5	013	2
006	5	014	2
007	5	015	2
008	5	016	2

4 Select a zone number by using [<], [^], [v], and [>], and then press [●] (Confirm).

The "Address List" screen returns.

- The selected zone no. is displayed to the right of the address.
- The number in < > is the number of units for which the zone No. is set.
- You can make the settings for up to 64 units.
- An error screen is displayed if you set 65 or more units.

Set the indoor unit as being out of the scope of management.

Zone Settings <64> (1/4) # Next			
001	1	009	1
002	001-002	001	1
003	1	2	3
004	3	4	5
005	6	7	10
006	8	9	10
007	10	Del	10
008	2	016	10

On the "Zone List" screen, select "Del" then press [●] (Confirm)

The display returns to the "Address List" screen.

- The zone number is deleted and will not be included in the number of units on the All screen.

Delete zone setting

IMPORTANT

After "Delete zone setting", the number of controlled / monitored units will be 0. Reset any zone.

Delete zone setting
Delete all.
Is it OK?
Yes
No

1 On the "Zone Settings" screen, select "Delete zone setting" then press [●] (Confirm)

The "Delete zone setting" confirmation screen appears.

2 Press [^] and [v] to select "Yes", then press [●] (Confirm)

"It has been deleted" appears and the display returns to the "Zone Settings" screen.

3-5. Other Functions

Connection Confir. List

You can confirm the operating status of central control addresses 1 to 128.

Servicing Menu(2/2)	
6. CRC Mode Change Conf.	
7. DN setting	
8. Communication Conf.	
9. Communication Check	
10. Register Contact Info	

1 In "Servicing Menu", select "Communication Check" and then press [●] (Confirm).

The "Communication Check" screen is displayed.

Communication Check	
1. Connection Confir. List	
2. Communication Quality	

2 Select "Connection Confir. List" by using [^] [v], and then press [●] (Confirm)

The "Connection Confir. List" screen is displayed.





Connection Confir. List (1/8)					
001	1	OFF	009	2	OFF
002	1	OFF	010	2	■!
003	1	OFF	011	2	■!
004	1	OFF	012	2	OFF
005	1	OFF	013	2	OFF
006	1	OFF	014	2	OFF
007	1	OFF	015	2	OFF
008	1	OFF	016	2	■!

3 Change the page by using [^] and [v].

The order of display priority is as follows.

Check > Notice > FILTER > Lock > ON > OFF

Operation status
Zone No.
Central control address

Icon	Description
Blank	Central control address to which an air conditioner is not connected.
OFF	Unit is not operating.
ON	Unit is operating.
	Key lock is set. (The number inside the icon indicates the lock number that is set.)
	The filter sign is displayed.
	A notice code is being issued.
	An abnormality is occurring.

DN Setting

DN setting
For use during servicing.
Change settings?
Yes
No

1 In the "Servicing Menu" screen, select "DN setting" and then press [●] (Confirm).

The "DN setting" screen is displayed.

2 Select "Yes" using [^] and [v], and then press [●] (Confirm).

The "DN setting" screen is displayed.

- You can select either "Central control Address order" or "Line Address order" to display the list of indoor units.

3 Select "Central control Address" by using [^] and [v], and then press [●] (Confirm).

The "Address List" screen is displayed.

- Press [↑↓] (Control) to go to the next page.

DN setting
1. Central control Address
2. Line Address

◆ When Central control address is selected

DN setting	(1/4) ↑↓ Next
001	009
002	010
003	011
004	012
005	013
006	014
007	015
008	016

4 Select an address by using [<], [^], [v], and [>], and then press [●] (Confirm).

The "Change Data" screen is displayed.

DN setting	
Code (DN)	Data
1F	0028

5 Select an item code (DN) or data by using [<] and [>], and then change the values by using [^] and [v].

6 Press [●] (Confirm).

The "Change DN setting" screen is displayed.

DN setting
Change other data settings?
Yes
No

7 Select "No" using [^] and [v], and then press [●] (Confirm).

The "Hourglass ⌚" screen is displayed, and then the "Servicing Menu" screen is displayed again.

- This operation requires several minutes.
- Select "Yes", and then press [●] (Confirm) to return to the "Change Data" screen.

NOTE

After setting items via "DN Setting," be sure to follow procedure 7. After selecting "Yes" and pressing the Return button to finish this setting, it is possible that the central remote controller may not be rebooted and that the setting values of the local remote controller and the central remote controller may not match.

Settings to Connect a Machine That Has No Remote Control

When you use a remote-less unit to connect indoor units that are compatible with TU2C-LINK, you need to use one of the following methods to do remote-less settings for the indoor unit.

- On the wired remote controller change DN [103] from 0 (with remote controller) → 1 (remote-less)
- On the energy-saving neo remote controller change DN [103] from 0 (with remote controller) → 1 (remote-less)

* If these settings are not done, a Check Code E03 (Indoor - Remote controller communication error) is detected.

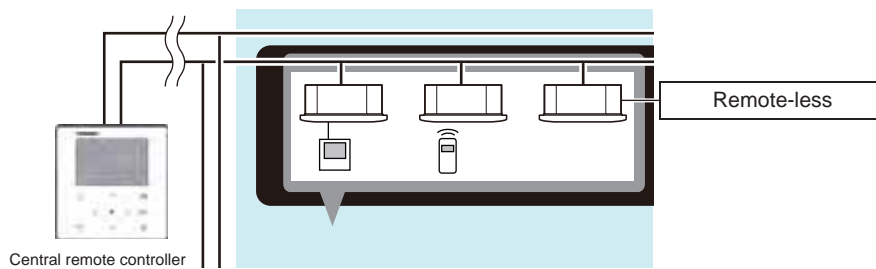

4 Troubleshooting

	Situation/Question	Cause	Response to Situation/Question
1	LCD does not display.	Power does not turn on.	Check whether the power has been cut off at the circuit breakers.
2	LCD is dark.	The backlight is off.	The backlight turns off when there are no operations for an extended period. Touch a key to turn it on. The lighting time can be changed in "Menu" → "Screen Display Settings" → "Backlight".
3	Air conditioners cannot be operated.	The address of the air conditioner being operated is different.	Confirm the address shown on the local remote control of the air conditioner you want to operate with the address of the air conditioner being operated at the device.
4		Zone setting is incorrect.	Do an "All start", if operation is then possible, the zone that is set may be incorrect. Confirm whether the zone setting is correct.
5		The device is in Local Control Mode.	When the device is set to Local Control Mode, if "Key lock" is set from some other Central Control Device, then the device operations are restricted, in the same way as the local remote control.
6	I want to turn off the power.	—	There is no main power switch on the main unit, so turn off the circuit breaker.
7	I want to do a restart.	—	Press the reset button on the left side of the main unit.
8	Air conditioner settings are changing by themselves.	The set temperature is being changed from a local remote control or from some other Central Control Device.	Check whether operations are being done from a local remote control or from some other Central Control Device. If you want to prohibit operations from a local remote control, set "Key lock (P.52 in Owner's Manual)".
9		Air conditioner was stopped by the schedule settings of the local remote control.	Even after being operated by the device, the air conditioner is stopped by the schedule of the local remote control. The most recent operations have priority if there are operations from both the device and the local remote control.
10		Air conditioner is set to stop by a signal from an external input.	If the air conditioner is set to stop by a signal from an external input by an external linking function, then the air conditioner stops automatically when the signal is input.
11		Schedule function of the device is operating.	When the "Weekly display" screen is updated to a new week, all the initial settings become "○(ON)" and operations are done according to the schedule set for each day of the week.
12	Schedule does not operate.	Schedule settings have been turned off.	Confirm whether "Operating Sch Enable/Void" or "Operating Sch settings" has been disabled in "Schedule settings".
13		The air conditioner set in the schedule is not the same as the actual air conditioner.	The schedule settings may be set for separate zones. Confirm whether the air conditioner whose schedule you want to set is set for the selected zone.
14		A special day schedule is set.	On days set as a special day, operations are executed according to the schedule set in "Sp1" or "Sp2", not the schedule set for the day of the week.
15	No cooling or no heating.	"Power peak cut" is set in "External Input Settings".	Demand control is a control that restricts performance of the outdoor unit to reduce power consumption. Because of this, reaching the set temperature may take some time.
16		"Thermo OFF" is set in "External Input Settings".	Forced thermo off is a control that stops operation of outdoor units. Because of this, the indoor units operate in Fan mode.
17		"Energy saving operation" or "Energy Saving Schedule" is set.	The "Energy saving operation" and "Energy Saving Schedule" controls restrict the performance of the air conditioners. Because of this, reaching the set temperature may take some time.

	Situation/Question	Cause	Response to Situation/Question
18	Settings displayed on the local remote control and the settings displayed on the device do not match.	The air conditioner being operated is not the same as the actual air conditioner.	Operate some other air conditioner and confirm whether the actual air conditioner is being operated.
19		The types of unit registered to the zone are different.	Reboot the whole system. Check the line address, indoor address, and central control address, and confirm that the zones to which the Air to Water Heat Pump and air conditioner are registered are correct. The Air to Water Heat Pump and air conditioner cannot be set to the same zone.
20	When the power is shut down and then restored while operation of the local remote control is prohibited, then the prohibition of using the local remote control is released.	The settings in "Communication Conf." in "Servicing Menu" are incorrect.	Set "Communication Conf." in "Servicing Menu" as shown below. Set "0" for SW2-1 to maintain prohibition of using the local remote control when the power is shut down and then restored while operation of the local remote control is prohibited.
21	I want to reset the filter sign even though the filter sign is not displayed.	—	If you clean the filters before the filter sign is displayed, you can reset the filter sign to reset the accumulated time.
22	I want to combine operations with another central control devices.	—	If the models support TU2C-LINK, then combining operations with all the Central Control Devices, including this device, and a maximum of 20 units, is possible. To combine operations, set a central controller ID in "Servicing Menu" → "Communication Conf.". (Please refer to the "Installation Manual (P.29 to 30)" for details.)
23	I want to combine use of multiple Central control devices.	—	If the models support TU2C-LINK, then combining operations with all the Central Control Devices, including this device, and a maximum of 20 units, is possible. To combine operations, set a central controller ID in "Servicing Menu" → "Communication Conf.". (Please refer to the "Installation Manual (P.29 to 30)" for details.)
24	Control by optional board in outdoor unit for connecting to multiple indoor units does not work.	Functions on optional boards for outdoor units are disabled when a central remote controller is connected.	Use either a central remote controller or the optional board for outdoor units.
25	Air conditioners do not turn ON/OFF even though the ON link signal/OFF link signal is input.	Link signal has been being input since the system started.	If the link signal has been being input since start up, then link controls are not executed, which is because their status is confirmed by detecting the rising/falling edge of the link signal. Set the link signal to be OFF at start-up.
26	The order that air conditioners are displayed is strange.	The initial setting is to be displayed in ascending order of central control addresses.	You can select either "Central control Address" or "Line Address" to display air conditioners in "Servicing Menu" → "Display settings" → "Unit Order Setting".
27	The value for the reference temperature is strange.	The reference temperature is the temperature for compensating the inlet temperature for controlling room temperature of the air conditioners.	It is different from the actual room temperature because the amount of compensation differs depending on the operation mode (cooling or heating).
28	Operations using local remote control are not possible.	"Key lock" is set.	Check the setting for "Key lock (P.52 in Owner's Manual)" on the central remote controller. To release it, change the "Key lock" setting to "Unlock".

	Situation/Question	Cause	Response to Situation/Question
29	Indoor units do not operate according to their settings even though operations such as ON/OFF are set. They change back after some time passes.	Communications with air conditioners is not normal.	Confirm whether abnormalities were detected in communications with the air conditioners.
30		Indoor unit is set as a follower unit.	Change the header / follower settings of the air conditioners to be the same.
31		Operation settings for temperature range are set at the air conditioner.	If a temperature outside the set temperature range is set, the temperature is set to the upper- or lower-limit temperature of the range.
32		Incorrect address is set at the central remote controller or the address was changed from the local remote control.	Perform "Obtain Address (P.12)" to re-register the air conditioners.
33		The central controller is connecting the Air to Water Heat Pump via the old controller mode.	The Air to Water Heat Pump cannot be controlled or monitored with the old controller mode.
34		Because the central controller is in the old controller mode, the indoor unit's address is within the TU2C-LINK-specific range.	If the central controller is in the old controller mode, set the indoor unit's address to one within the range indicated below. <ul style="list-style-type: none"> • Central control address:1-64 • Line address:1-31 • Indoor address:1-64
35	An inspection code other than S01 is displayed on the central remote controller screen.	An error was detected at an air conditioner.	Check the inspection display on the multi-outdoor board or the local remote control. Follow the service guides for the various air conditioners to check the parts and wiring and identify the problem.
36	"No connected indoor unit" is displayed.	All of the air conditioners are disconnected or their power is not on.	Even if only 1 air conditioner cannot communicate, then "No connected indoor unit" is displayed. Check the power and transmission wiring of the air conditioner, and then perform "Obtain Address".
37	What is the maximum number of air conditioners I can connect?	—	A maximum of 128 air conditioners can be connected, but only 64 units can be monitored and controlled.
38	Can I turn on and off lighting equipment, ventilating fans, and air conditioners of other manufacturers?	—	You can do this if you connect a general-purpose device control interface.
39	Can I incorporate use of a schedule timer that is sold separately?	—	No, you cannot.
40	Can I incorporate use of a touch-panel type air conditioner control system?	—	Yes, you can. But, it needs to be confirmed.
41	Can I incorporate use of a BACnet system?	—	Yes, you can. But, it needs to be confirmed.
42	Can I incorporate use of a LONwork system?	—	Yes, you can. But, it needs to be confirmed.
43	Can I incorporate use of a remote monitoring system?	—	Yes, you can. But, it needs to be confirmed.
44	Can I connect devices in the AI-NETwork series?	—	No, you cannot. Use an air conditioner control system that supports the AI-NETwork series.
45	Can I change the names of the zones?	—	You can change them at "Menu" → "Zone Name Settings".
46	How many characters can I set for a zone name?	—	You can set 9 byte characters.

	Situation/Question	Cause	Response to Situation/Question
47	How many check codes can be saved?	—	Up to 300 can be saved. If there are 301 or more, the check code histories are deleted in order from the oldest.
48	Can I delete the check codes?	—	You can delete them from "Check/Notice Settings" in "Servicing Menu".
49	Are any special operations needed to turn off the power to the controller?	—	You do not need to do any special operations.
50	Does turning off the controller stop the air conditioners?	—	Air conditioners that are connected to a local remote control or wireless adapter do not stop when the controller is turned off. Air conditioners that are not connected to a local remote control or wireless adapter do stop.
51	Can I turn off all the indoor units simultaneously?	—	Yes, you can. In the "All" screen, do the OFF operation. Or, you can turn them all off by doing an external input of all stop from the central remote controller.
52	Can I monitor the operating status of the outdoor units?	—	No, you cannot.
53	Do the operations set to the air conditioners have a priority order?	—	The most recent has priority.
54	Is it possible to connect an indoor unit that has no remote control?	—	It is possible. Refer to "Settings to Connect a Machine That Has No Remote Control (P.20)".
55	I forgot the administrator's password.	—	In the "All" screen, press and hold [5] + [Λ] + [V] at the same time for 4 seconds; the "Admin. Password Initialization" screen is displayed, and you can initialize the password. After initialization, the password is set to "0000". Set a suitable password from the "Settings Menu".
56	I want to confirm the software version.	—	You can confirm it at "Menu" → "Information".
57	I cannot access "Servicing Menu".	A button was pressed while the backlight was off.	While the backlight is off, when you press a button, the only operation is that the backlight turns on. Press and hold [≡] + [↑↓] at the same time for 4 seconds while the backlight is on.
58	The reference temperature of the Air to Water Heat Pump is displayed as "----".	The Air to Water Heat Pump is under water temperature control.	When the Air to Water Heat Pump is set to water temperature control, the reference temperature is not displayed. When it is set to room temperature control, the reference temperature is displayed.
59	The Air to Water Heat Pump has become an ON/OFF device and an S01 error has occurred.	The central controller is set to old controller mode.	The Air to Water Heat Pump cannot be controlled or monitored with the old controller mode. Set the Central controller ID (Installation Manual P.29-30).
60	Temperature setting of the Air to Water Heat Pump at time of schedule operation	—	Via "Schedule settings," make the set temperature for ZONE2 no higher than that for ZONE1. If the set temperature for ZONE2 were set higher than that for ZONE1, the setting will automatically be changed via the controller at the scheduled time so that the set temperature for ZONE2 does not exceed that for ZONE1.
61	When you want to operate air conditioners and Air to Water Heat Pumps at the same time from the simultaneous display screen	—	In the settings process "Servicing Menu" → "All Unit ON/OFF Setting" (Installation Manual P.33), select "ALL Units."

	Situation/Question	Cause	Response to Situation/Question
62	When you want to operate ZONE1, ZONE2, and DHW at the same time	—	In the settings process "Servicing Menu" → "Air to Water Setting" (Installation Manual P.33), select "Zone1/2 and DHW ON/OFF."
63	When the number of indoor units is reduced after the central control address has been changed from the central remote controller.	—	If SMMS-u is connected, switch on the power to the indoor unit and outdoor unit again and perform the "Obtain Address" procedure again.
64	Regarding the "ZONE" for the central remote controller and the "ZONE" for the Air to Water Heat Pump	—	The central remote controller "ZONE" indicates the control group for the air conditioner and Air to Water Heat Pump, not the "ZONE" of the Air to Water Heat Pump.

5 Check Code List

Check Code display	Check Code Names
S01	Communication error between air conditioner and BMS
S02	BMS-IFLSV Communication error
S03	Group terminal unit error
S04	BMS-IFWH Communication error
S05	-
S06	BMS-IFWH Communication error
S07	BMS-IFDD Communication error
S08	Communication error
S09	Communication error
S10	-
S11	-
S12	Other error
S13	-
S14	Start failure
S15	File access error
S16	IP address setup error
S17	File load error
S18	-
S19	-
S20	-
S21	Mail transmission error
S22	Internal communication error 1
S23	Setting file read error
S24	-
S25	Schedule file read error
S26	Schedule file write error
S27	Daily report/Monthly report file read error
S28	Daily report/Monthly report file write error
S29	Application error
S30	System error
S31	Internal communication error 2
S32	Alarm activation
S33	System controller address duplication error

* For the check codes other than above, refer to the check code list of the air conditioner.

Installation Manual

For commercial use

Central Remote Controller

TU2C-LINK / TCC-LINK compatible

Model name

TCB-SC640U-E
TCB-SC640U-TR
TCB-SC640U-ME



Multilingual installation manuals and owner's manual



[Български] Изтегляне на Ръководство за монтаж и Ръководство на потребителя / [Česky] Stažení Instalační příručky a Uživatelské příručky / [Dansk] Download af installationsvejledning og brugervejledning / [Deutsch] Installationshandbuch und Bedienungsanleitung herunterladen / [Ελληνικά] Λήψη εγχειριδίου εγκατάστασης και εγχειριδίου κατόχου / [English] Installation manual and Owner's manual Download / [Español] Descarga del Manual de instalación y del Manual del propietario / [Eesti] Paigaldusjuhendi ja kasutusjuhendi allalaadimine / [Suomi] Asennusohjeiden ja käyttöohjeiden lataaminen / [Français] Téléchargement du manuel d'installation et du manuel du propriétaire / [Hrvatski] Preuzimanje Instalacijskog priručnika i Vlasničkog priručnika. / [Magyar] Telepítési kézikönyv és Felhasználói kézikönyv letöltése / [Italiano] Download del Manuale di installazione e del Manuale dell'utilizzatore / [] / [Latviešu] Uzstādīšanas rokasgrāmatas un lietotāja rokasgrāmatas lejupielāde / [Norsk] Nedlasting av installasjonsveiledning og bruksanvisning / [Nederlands] Installatiehandleiding en Handleiding downloaden / [Polski] Pobieranie Instrukcji instalacyjnej oraz Instrukcji użytkownika / [Português] Download do Manual de instalação e Manual do Proprietário / [Română] Descărcarea Manualului de instalare și a Manualului proprietarului / [Русский] Скачать Руководство по установке и Руководство пользователя / [Slovensky] Stiahnutie Montážnej príručky a Uživatelskej príručky / [Slovenščina] Prenos navodil za montažo in navodil za uporabo / [Svenska] Nedladdning av installationshandbok och bruksanvisning / [Türkçe] Kurulum kılavuzu ve Kullanıcı kılavuzu indirme / [中文] 安装手册和用户手册下载 / [عربی] دليل التثبيت ودليل المالك تنزيل





<https://www.toshiba-carrier.co.jp/global/manual/tcb-sc640u.htm>

Contents

1	Safety Precautions	3
2	Specifications	4
3	Installation	6
	3-1. Power, Signal, and Earth Line Connections	6
	Connect the power supply wire and the ground wire	6
	Connect the signal wires	6
	3-2. How to Install	13
4	Central Remote Controller Test Run	14
5	"Servicing Menu" Settings	16
	Register/Check Indoor Unit (Address Settings)	17
	Change the Zone to which the Indoor Unit Belongs (Zone Settings)	20
	To Change the Group Zone of Multiple Indoor Units	21
	Set the indoor unit as being out of the scope of management.	22
	Changing the Display Method (Display settings)	23
	Delete the History and Set the Notice Code (Check/Notice Settings)	25
	Changing the External Input Function (External Input Settings)	26
	Switch Operation Mode (CRC Mode Change Conf.)	28
	Change the Indoor Unit Data (DN setting)	28
	Change Communication Configuration (Communication Conf.)	29
	Check the Connection Status of the Indoor Units (Communication Check)	31
	Register Contact Information when an Error Occurs (Register Contact Info)	32
	ALL Unit ON/OFF Setting	33
	Air to Water Setting	33



1 Safety Precautions

- Read these "Safety Precautions" carefully before installation.
- The precautions described below include important items regarding safety. Observe them without fail.
- Understand the following details (indications and symbols) before reading the body text, and follow the instructions.
- After the installation work has been completed, perform a trial operation to check for any problems. Explain how to use and maintain the unit to the customer.
- Ask customer to keep this Manual at accessible place for future reference.



Display Description	Symbol Description
 WARNING Indicates "Content that is expected to result in death or serious injury (*1) to the user in the case of incorrect handling".	 ⓧ indicates prohibited actions. Specifically prohibited contents are indicated with a picture and/or text in or near the symbol.
 CAUTION Indicates "Content that is expected to result in minor injury (*2) to the user or damage to property (*3) in the case of incorrect handling".	 ⓘ indicates instructions which must be followed. The actual contents of the instructions are indicated with a picture and/or text in or near the symbol.

*1: Serious injury refers to lasting after effects such as blindness, injury, burns (high temperature / low temperature), electric shock, bone fracture, or poisoning, etc. and injuries that require hospitalization/long-term outpatient treatment.
 *2: Minor injury refers to injuries, burns, or electric shocks, etc. that do not require hospitalization or long-term outpatient treatment.
 *3: Damage to property refers to extended damage related to houses, household goods, livestock, or pets, etc.

⚠ WARNING

 Prohibited	Do not modify the unit. A fire or an electric shock may occur.	 Compulsory	<ul style="list-style-type: none"> • Ask an authorized dealer or qualified installation professional to install or reinstall this unit. Inappropriate installation may result in electric shock or fire. • Electrical work must be performed by a qualified electrician in accordance with this installation manual. The work must satisfy all local, national and international regulations. Inappropriate work may result in electric shock or fire. • Be sure to turn off all main power supply switches before starting any electrical work. Failure to do so may result in electric shock.
 Compulsory	Always connect to ground Improper grounding may result in an electric shock. Before connecting the power, carry out Class D grounding according to the "Engineering Standard for Electric Work" and the "Internal Wiring Regulations".		

⚠ CAUTION

 Prohibited	Do not install in the following locations <ul style="list-style-type: none"> • Locations where combustible gas may leak • Locations with high humidity or water • Dusty locations • Locations in direct sunlight and locations subject to high temperatures • Locations within 1 m from televisions or radios • Outdoors, under awnings, or other locations exposed to rain and dew • Locations exposed to outside air containing corrosive gases or salinity • Locations with frequent vibrations 	 Compulsory	<ul style="list-style-type: none"> • In installation work, use wiring with the correct ampacity. Failure to do so may result in excessive heat or fire. • Use specified cables and connect them securely, and do not subject connecting terminals to external force. Doing so may result in broken cables, excessive heat or fire. • Always install a circuit breaker on the primary side of the power supply. • When attaching to a metal lath, wire lath or wooden structure with metal boards, attach it to the control panel, etc. without attaching it to the wall.
---	---	---	--

2 Specifications

Product name	Central Remote Controller
Model Name	TCB-SC640U-E, TCB-SC640U-TR, TCB-SC640U-ME
Power supply	220-240 V AC 50/60 Hz
Consumed current	0.06 A
Number of connected units	Up to 64 units
External contact inputs	3
External contact outputs	2
Operating temperature/humidity range	0°C to 40°C, 10% to 90% RH (no condensation)
Dimensions	H120xW120xD20 (+50.6) (Embedded dimensions shown in parenthesis)
Mass	550 g

■ Outline Drawing

(Unit: mm)

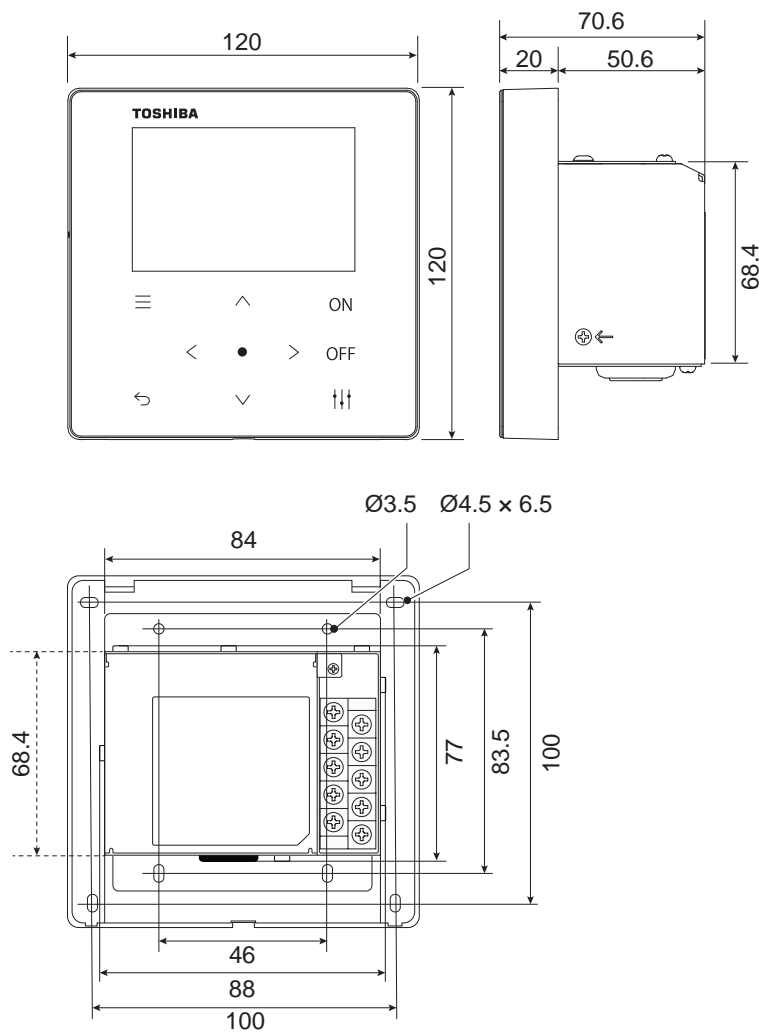

■ Component Names

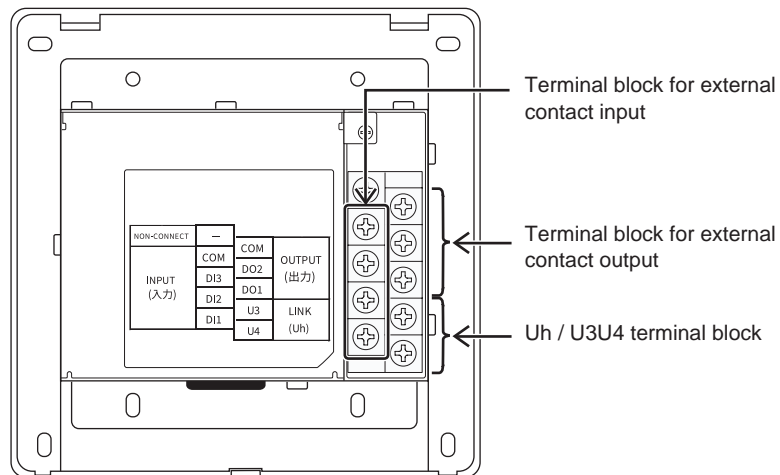

Name	Functions
Terminal block for external contact output	Connect the external contact output
Terminal block for external contact input	Connect the external contact input
Uh / U3U4 terminal block	Connect the central control wiring

■ Before Installation

Confirm that all the parts listed below are included in the package.

Included items

No.	Component name	Q'ty	Remark
1	Central Remote Controller main unit	1	
2	Owner's Manual	1	
3	Installation Manual	1	
4	Fixing screw	4	M4×20
5	Fixing screw	4	M3.8×16

Wiring specifications

Use the following wiring material to connect signal wires and power supply wires. (Locally procured)

No.	Wiring	Wire type / wire diameter / wire length
1	For Uh / U3U4 terminal	Refer to "Design of Control Wiring" (P.8~P.11).
2	For power supply	0.75 mm ² , up to 50 m
3	For digital I/O	2-core cable 0.3 mm ² , up to 100 m

3 Installation

3-1. Power, Signal, and Earth Line Connections

Connect the power, signal and earth lines to the specified terminal blocks.

REQUIREMENT

Attach round crimp terminals to all TU2C-LINK / TCC-LINK wiring and tighten the screws securely. After tightening, check that the wiring cannot come out.

Connect the power supply wire and the ground wire

- (1) Remove 3 cover fixing screws pointed to by arrows and open the cover
- (2) Insert cross notches in the rubber bushing in order to pass the power supply cable
- (3) Pass the power supply cable through the rubber bushing and the clamp, and connect the power supply wire and the ground wire to the specified terminal block
- (4) Close the cover and secure with 3 cover fixing screws

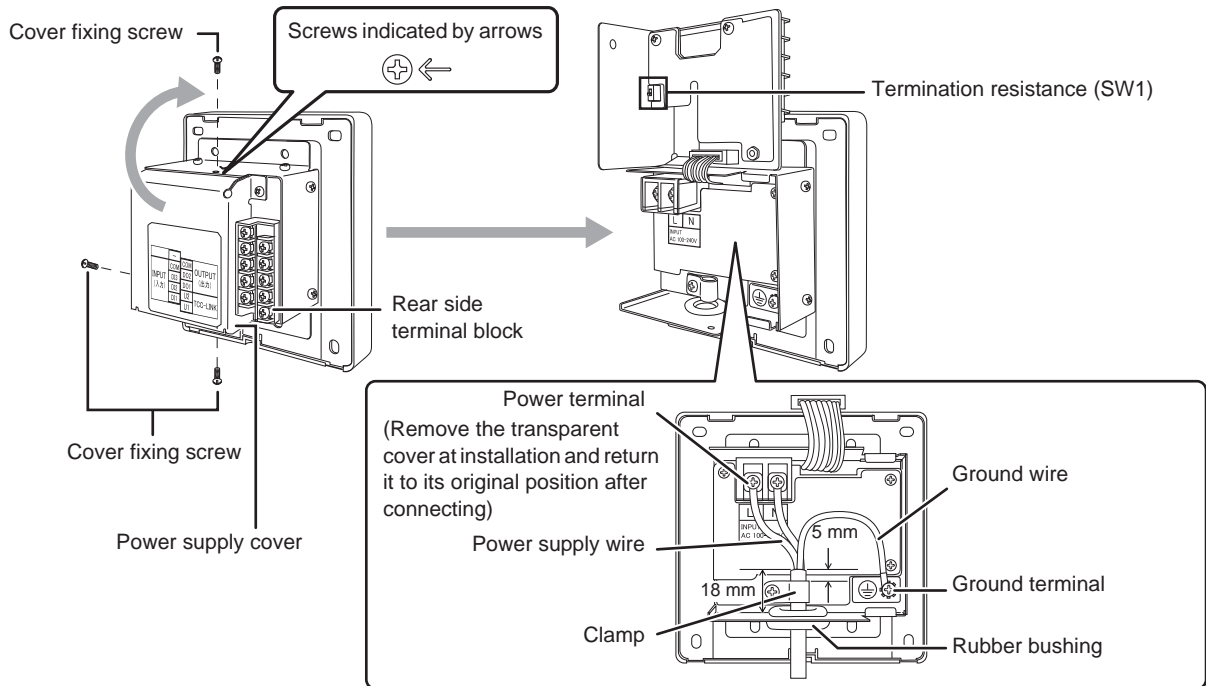

Connect the signal wires

Connect the TU2C-LINK / TCC-LINK signal wire (Uh / U3U4) to the terminal block

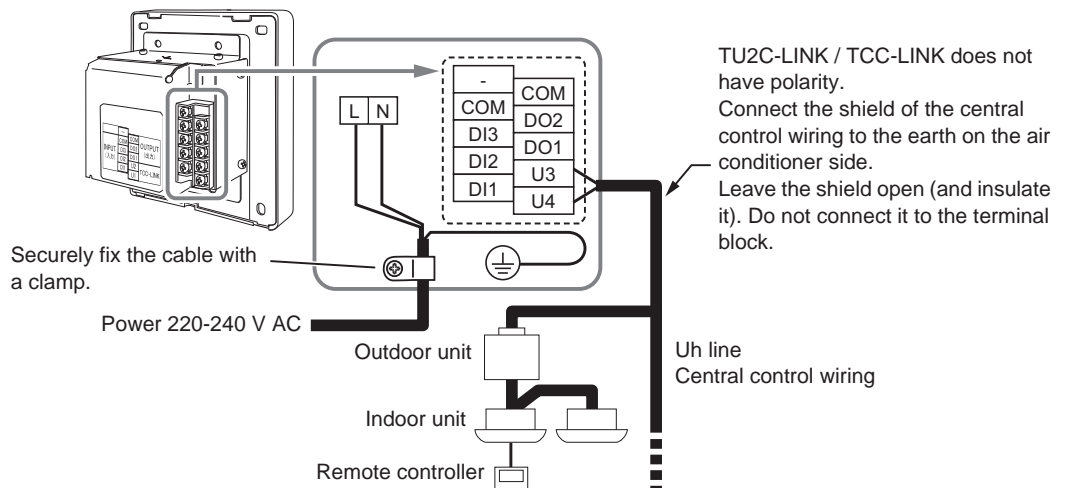

■ About Stripping Length

(Unit: mm)

Power supply wire stripping length

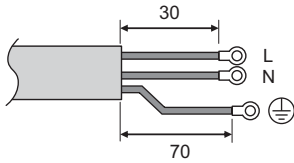

Attach a round crimp terminal to each wire of the power supply wire.

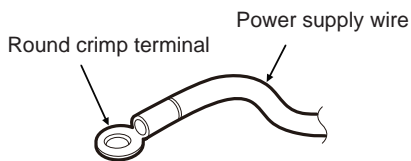

Central control wiring stripping length

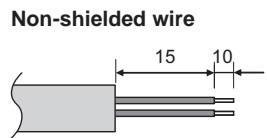
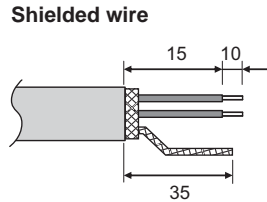

Digital I/O cable stripping length

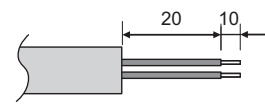

Termination resistance setting

- TU2C-LINK / TCC-LINK termination resistance setting<For TCC-LINK>

Leave just 1 line of the termination resistance in the interface board of the outdoor unit (centre unit) ON, and turn all the others OFF. (Refer to the wiring diagram attached to the outdoor unit for the position of SW.)

<For TU2C-LINK>

For the central control wiring (Uh line), set the termination resistance that is farthest away on the wiring between this central controller and the other unit (VRF light commercial, air to air heat exchanger, general purpose control interface, air to water heat pump) to ON.

Refer to the manual of each model for the termination resistance setting method.

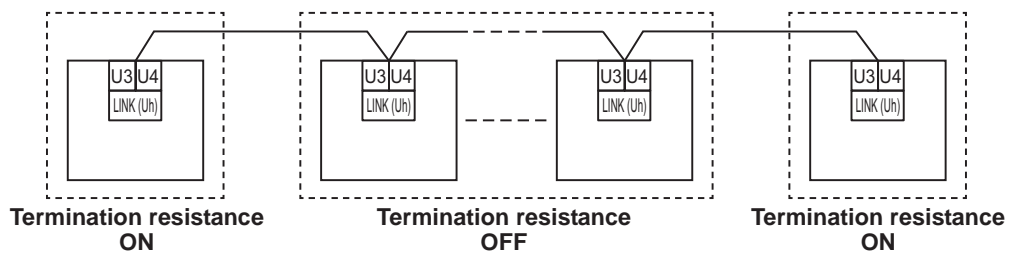

Shield grounding process

- Central control wiring shielded wireWhen using the central remote controller with one unit, open the shielded wire of the central control wiring and perform insulation processing.
When using the central remote controller with multiple units, connect the shield of the central control wiring to the closed end and open the shield at the final end of the central remote controller to perform insulation processing. Perform the central control wiring shield grounding on the air conditioner side.

REQUIREMENT

- Be sure to install a circuit breaker or all-pole isolating switch (with a contact breaking distance of at least 3 mm) on the primary side of the power supply.
- Fasten the screws to the terminal block with torque of 0.5 N•m.

■ Design of Control Wiring

Communication method and model name

The TU2C-LINK model (U series) can be used together with previous models (other than U series).

For details of the model and communication method, see the following table.

Communication method	TU2C-LINK (U series)	TCC-LINK (other than U series)
Outdoor unit	MMY-MUP*** ↑ _____ U series model	Other than on the left (MMY-MAP***, MCY-MAP***, etc.)
Indoor unit	MM*-UP*** ↑ _____ U series model	Other than on the left (MM*-AP***, etc.)
Wired remote controller	RBC-AMSU** ↑ _____ U series model	Other than on the left
Wireless remote controller receiver	RBC-AXRU** ↑ _____ U series model TCB-AXRU** ↑ _____ U series model	Other than on the left
Central control device	***_***U** ↑ _____ U series model	Other than on the left

When the connected outdoor unit is Super Multi u series (U series)

Follow the wiring specifications in the table below even when there is a mix of U series and non-U series in the connected indoor units or remote controllers.

Wiring specifications

Item	Communication line
	Central control wiring (Uh line)
Wire diameter	1.0 to 1.5 mm ² (up to 1000 m)
	2.0 mm ² (up to 2000 m)
Wire type	2-core, non-polar
Wire types that can be used	Shielded wire

REQUIREMENT

When wiring the control wiring between indoor and outdoor units (Uv line)/control wiring between outdoor units (Uc line) and the central control wiring (Uh line), use the same wire type and diameter for each line. Using a mixture of different wire types and diameters may cause a communication error.

System diagram

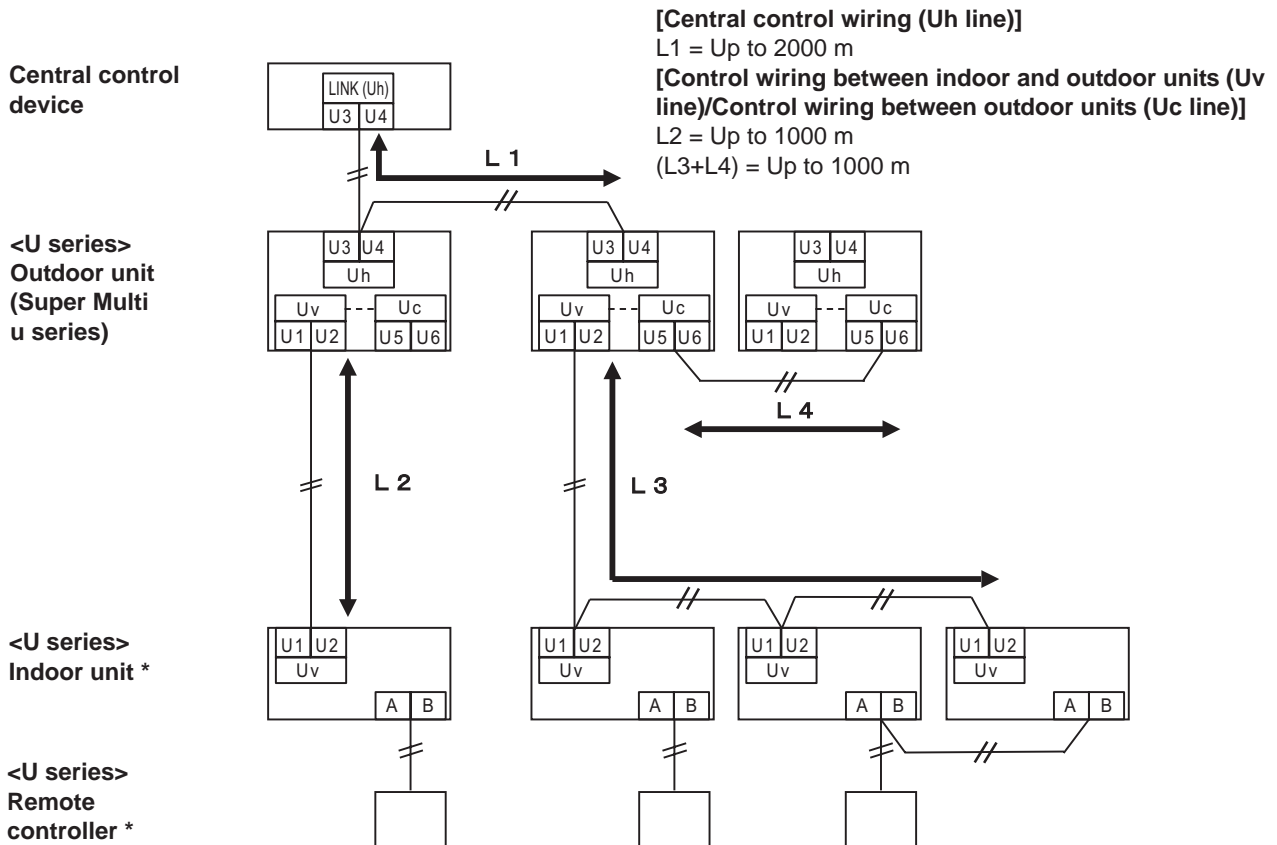

* The wiring specifications in the system diagram above are the same even when the indoor unit or remote controller are other than the U series.

When the connected outdoor units are other than Super Multi u series (U series)

Wiring specifications

Item	Communication line
	Control wiring between indoor and outdoor units and central control wiring
Wire diameter	1.25 mm ² (up to 1000 m)
	2.0 mm ² (up to 2000 m)
Wire type	2-core, non-polar
Wire types that can be used	Shielded wire

REQUIREMENT

When wiring the control wiring between indoor and outdoor units/central control wiring and the control wiring between outdoor units, use the same wire type and diameter for each line.

Using a mixture of different wire types and diameters may cause a communication error.

System diagram

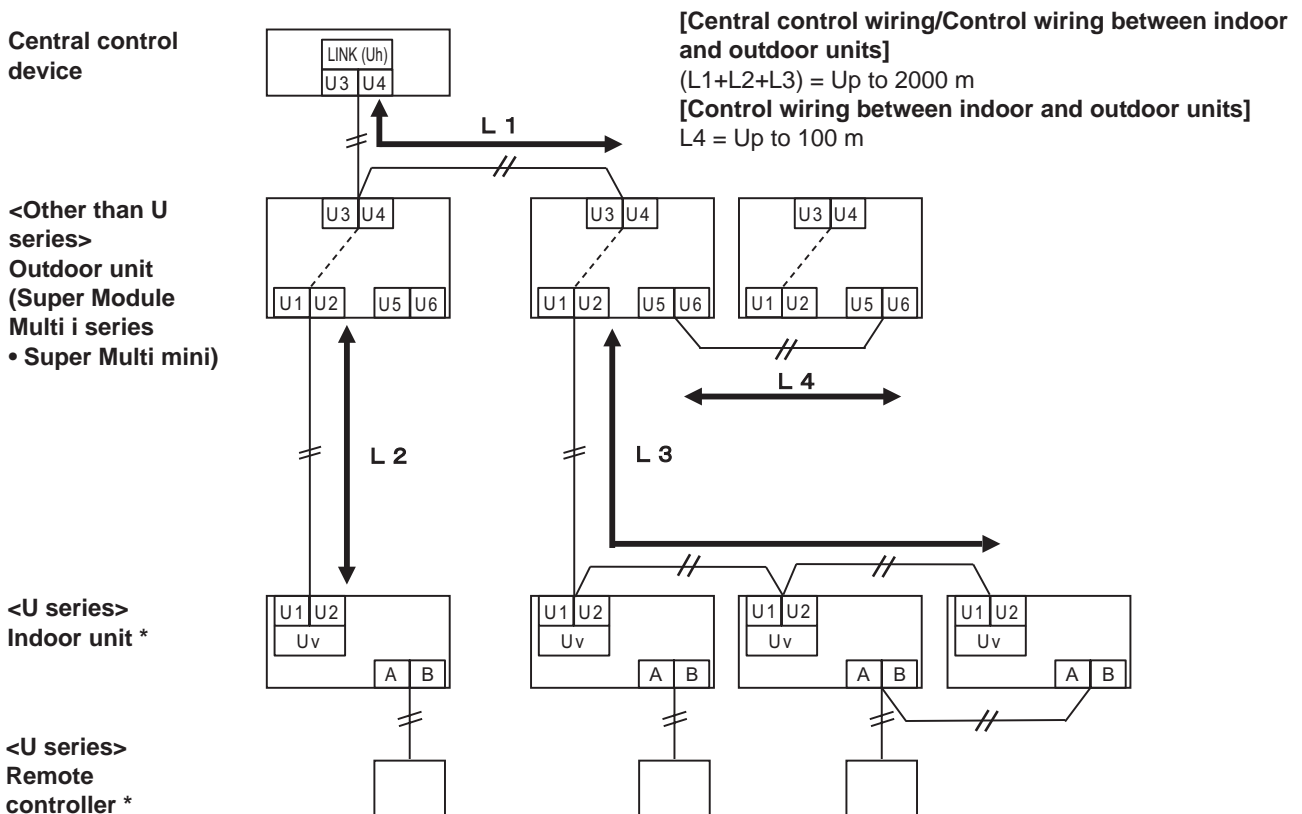

* The wiring specifications in the system diagram above are the same even when the indoor unit or remote controller are other than the U series.

When connecting to a previous model light commercial, air to air heat exchanger, air to water heat pump, or general purpose equipment control interface

Follow the wiring specifications in the table below even when there is a mix of U series and non-U series in the connected indoor units or remote controllers.

Wiring specifications

Item	Communication line
	Central control wiring (Uh line)
Wire diameter	1.25 mm ² (up to 1000 m)
	2.0 mm ² (up to 2000 m)
Wire type	2-core, non-polar
Wire types that can be used	Shielded wire

REQUIREMENT

When wiring the control wiring between indoor and outdoor units (Uv line)/control wiring between outdoor units (Uc line) and the central control wiring (Uh line), use the same wire type and diameter for each line. Using a mixture of different wire types and diameters may cause a communication error.

System diagram

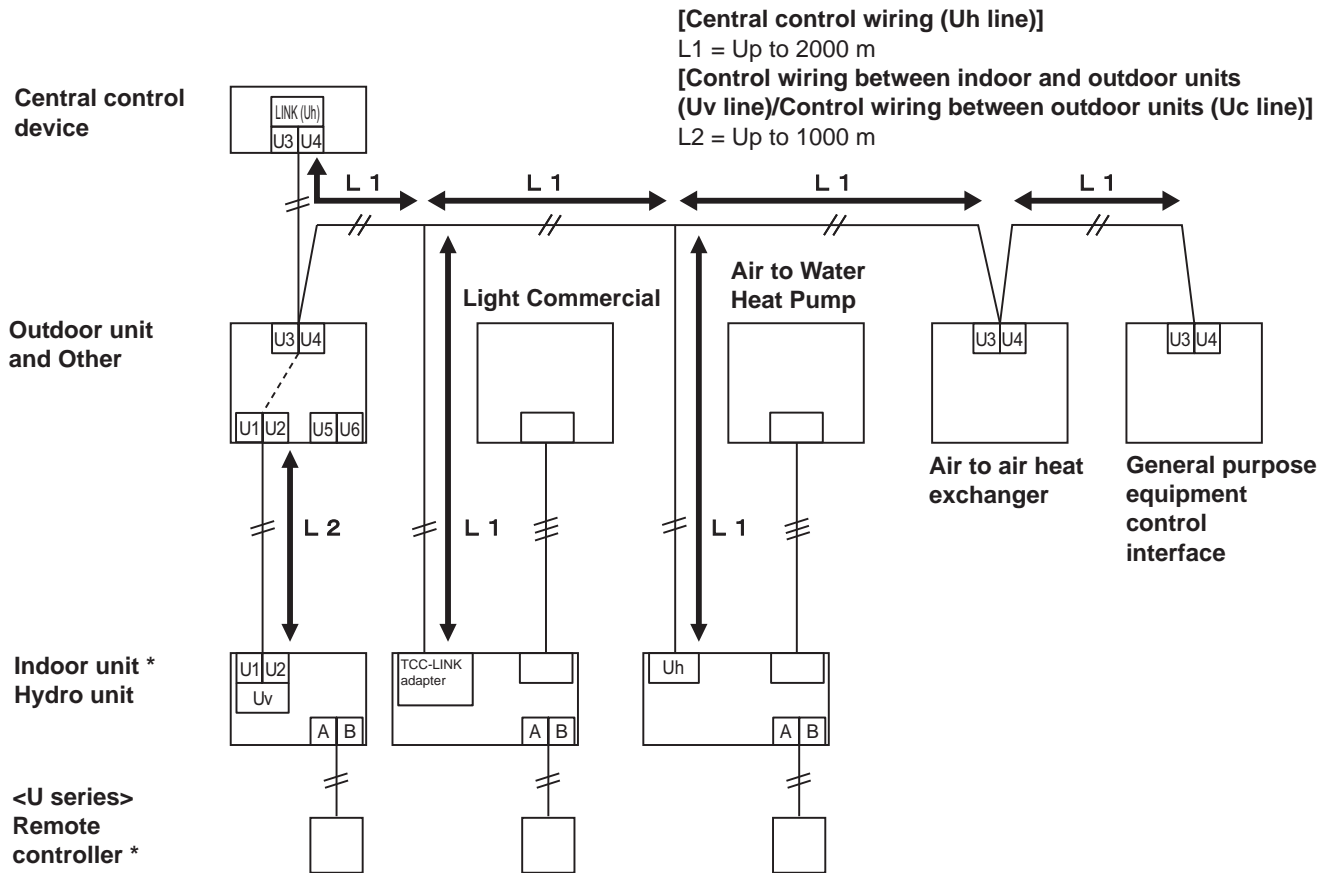

* The wiring specifications in the system diagram above are the same even when the indoor unit or remote controller are other than the U series.

■ Connection to External Equipment

Connect to external equipment (digital I/O signal wire)

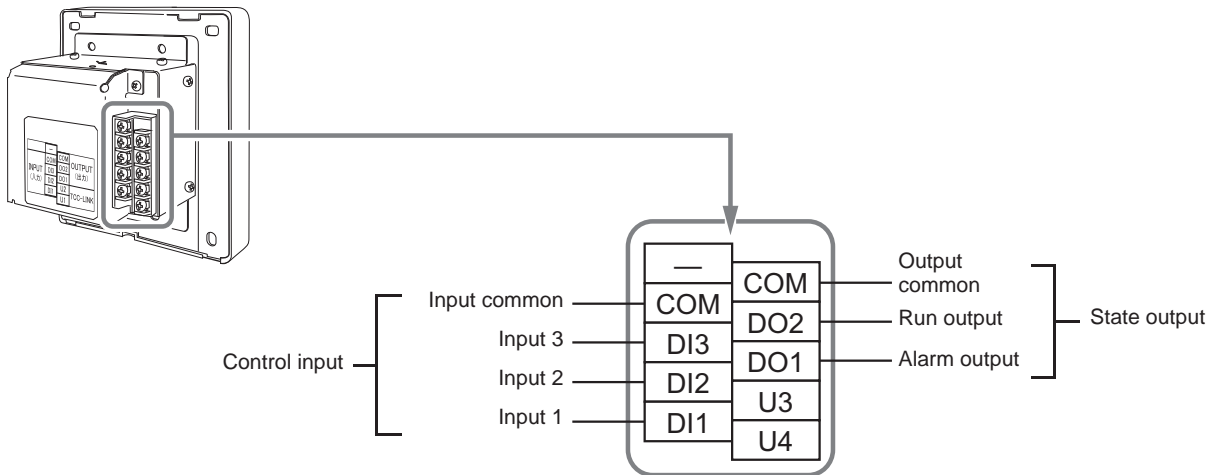

*Functions can be assigned to inputs 1 to 3 using "Changing the External Input Function (External Input Settings) (P.26)".

Name	I/O Item	This unit side			Equipment side	
		I/O conditions	Circuit	Terminal name	Circuit example	I/O conditions
Digital I/O terminal	State output	Alarm output Run output No-voltage contact A static Contact permissible voltage/current DC24 V / 35 mA		Alarm Run Output common		
	Control input	No-voltage contact A/B Pulse or static No-voltage contact compatible with very small current must be selected DC5 V / 3 mA		Input 1 Input 2 Input 3 Input common (-) COM		Pulse width: 300 ms or more

* Wire the cables so that the user does not touch the power supply directly.

* On the equipment side, use a basically insulated power circuit and place it in a location that where the user cannot touch it.

NOTE

- Do not connect the device directly to the primary side of the power supply. Be sure to install a circuit breaker or all-pole isolating switch (with a contact breaking distance of at least 3 mm) on the primary side of the power supply.
- Fasten the screws to the terminal with torque of 0.5 N•m.

3-2. How to Install

⚠ CAUTION

- Do not wire communication lines (control wiring between indoor and outdoor units, central control wiring) or input/output wiring next to power supply wiring, etc., or house them in the same metal pipe. Doing so may result in failure.
- Install the central remote controller away from noise sources.

■ When installing to control board (control panel) or to a wall

The thickness of the board or wall must be 1.6 mm to 10 mm.

- Prepare the holes for installation beforehand, following the the diagram below (Panel cut dimensions diagram).
- Remove 1 panel fixing screw and open the panel.
- Attach the lower case with the four included fixing screws.
- Close the panel and attach it with 1 panel fixing screw.

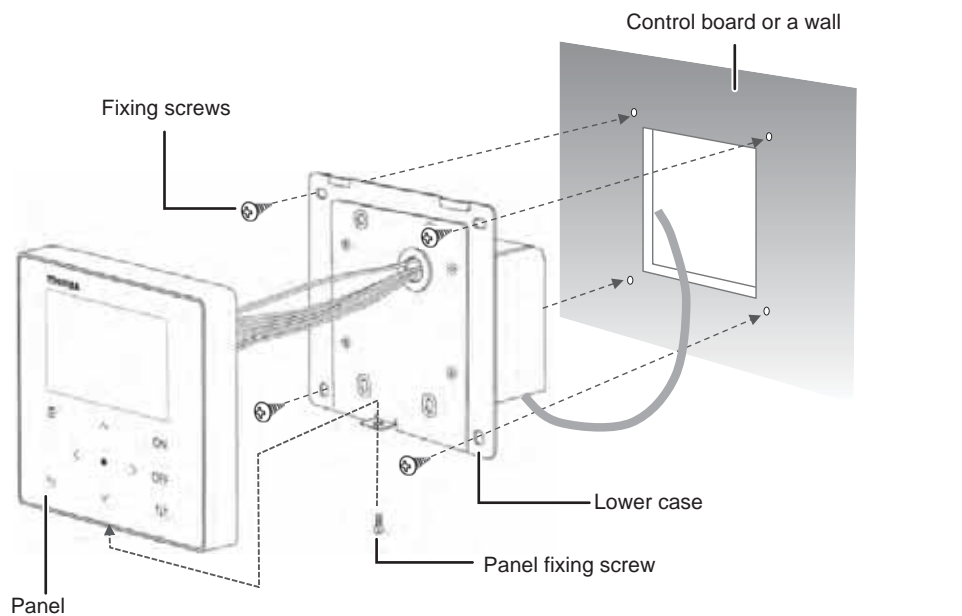

< Panel cut dimensions diagram >

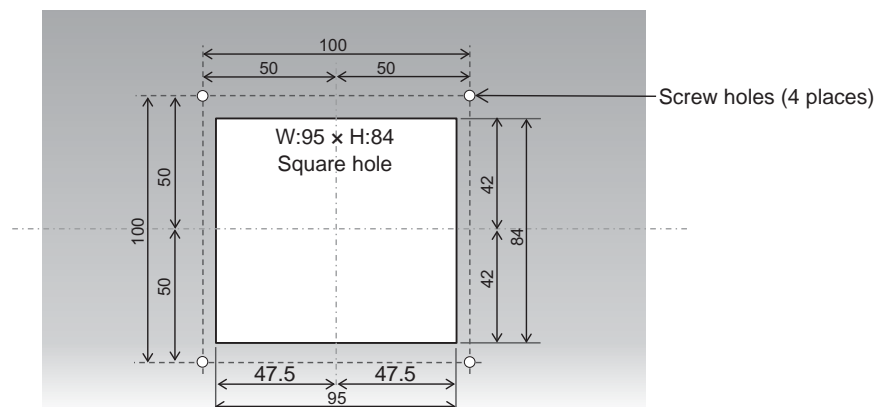

4 Central Remote Controller Test Run

- Set according to the following procedure before use.
This allows the unit to monitor and operate the air conditioners.

Example of All screen

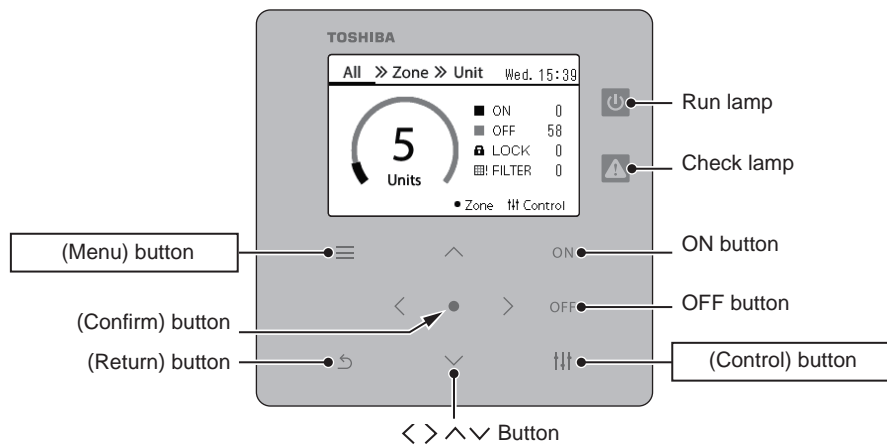

1 Turn on all connected equipment

- Indoor unit, outdoor unit, air to air heat exchanger, general purpose equipment control interface, etc.

2 Turn on the power of the Central Remote Controller

- A Central control address must be assigned to the indoor units to be controlled.
<Preparation for Central control address settings>
- A Central Remote Controller or wired remote control is required to set the Central control address.
- Set the Central control address after finishing the test run of the indoor unit.
- * If you wish to configure the settings with the Central Remote Controller, you must first complete initial communication with all connected indoor units and outdoor units. Wait at least 10 minutes after turning on the power to the air conditioner before configuring the settings.

NOTE

- If you configure the Central control address settings before initial communication with the outdoor units is fully completed, the address may not be set for some units.
- For the TCC-LINK model, perform the following settings.
Connect the U3 and U4 terminals in the outdoor unit (centre unit) to the relay connectors.

3 Register the indoor units to the unit

Press the [≡] and [↑↑] buttons simultaneously for 4 seconds or more on the All screen to move to "How to Display the "Servicing Menu" Screen (P.16-2)". Perform "Obtain Address (◆If you will not change the Central control address (P.17-1-2))" of "Address Settings".

After performing "◆If you will not change the Central control address (P.17-2)", check that there is no error in the displayed number of connected units, line address-indoor address, and Central control address (*1), then perform "◆If you will not change the Central control address (P.17-3)".

*1 If there is an error

- Check the power supply and wiring.
- To change the address, use the local remote controller or the unit ("◆To change the Central control address (P.18-3 to 4)").
- Repeat the setting in this section (3.Register the indoor units to the unit) from the beginning.

4 Assign indoor units to zones 1 to 10

Perform "Change the Zone to which the Indoor Unit Belongs (Zone Settings) (P.20-1 to 4)".

Return to the All screen and check if the displayed number of units matches the number registered in the zone (*2).

*2 Indoor units that are not registered in a zone are not included in the number of units on the All screen.

5 Operation confirmation

Check whether the indoor units can be operated from the Central Remote Controller.

Also, check whether the operation of the local remote controller is reflected on the Central Remote Controller.

6 Preparation for delivery

If an inspection code occurs during operation check, perform "Delete check history (P.25)".

This completes the test run for the controller.

For other detailed settings, refer to "Owner's Manual" and "Installation Manual (P16 to P33)".

Example of Obtain Address screen

Obtain Address	Line address	Indoor address	Central control address	(1/2) ↑↑ Next
001-006	006	001-014	014	
001-007	007	001-015	015	
001-008	008	001-016	016	
001-009	009	001-017	017	
001-010	010	001-018	018	
001-011	011	001-019	019	
001-012	012	001-020	020	
001-013	013	001-021	021	

Example of zone setting (Central control address) screen

Number of units that have been set

Zone Settings	Central control address	Zone No.	<64> (1/4) ↑↑ Next
001	1	000	1
002	1	010	1
003	1	011	3
004	1	012	3
005	2	013	10
006	2	014	10
007	2	015	10
008	2	016	10

5 "Servicing Menu" Settings

■ How to Display the "Servicing Menu" Screen

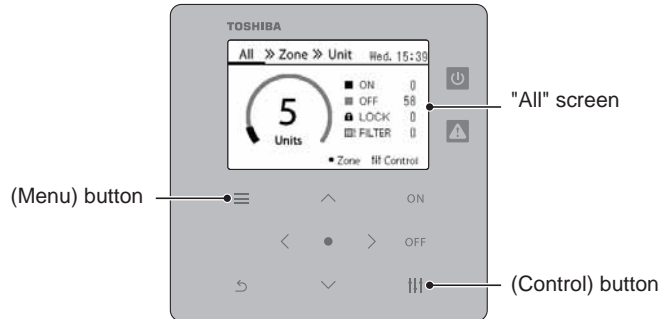

Servicing Menu(1/2)	
1.	Address Settings
2.	Zone Settings
3.	Display settings
4.	Check/Notice Settings
5.	External Input Settings

- 1 Display the "All" screen
- 2 Press [≡] (Menu) and [↑↑] (Control) together for more than 4 seconds

The "Servicing Menu" screen appears.

- 3 Press [^] and [v] to select the item, then press [●] (Confirm)

For details on the setting contents of each item, refer to "■ Servicing Menu Items".

■ Servicing Menu Items

No.	Setting Items		Description	Reference Page
1	Address Settings	Obtain Address	Obtains (register) indoor units and changes the Central control address.	P.17
		Address Display	Displays the registered indoor unit addresses.	P.19
		Address Auto-setting	Sets the Central control address automatically.	P.19
2	Zone Settings	Central control address	Assigns the registered indoor units to zones 1 to 10.	P.20
		Line Address		
		Delete zone setting	Deletes all zone settings.	P.22
3	Display Settings	Daylight-saving	Sets whether to display the daylight-saving time setting in the clock setting.	P.23
		Temperature Display Conf.	Sets the temperature display unit (°C/°F) and interval (1°C/0.5°C).	P.23
		Unit order setting	Changes the display order of indoor units on the Unit screen.	P.24
4	Check/Notice Settings	Delete check history	Deletes the check code history.	P.25
		Notice Settings	Sets the notice code and deletes the history.	P.25
5	External Input Settings		Sets the function to DI1 to DI3.	P.26
6	CRC Mode Change Conf.		Switches between Central control address Control Mode and Local Control Mode.	P.28
7	DN setting		Only service personnel should perform this work.	P.28
8	Communication Conf.		Changes the Communication Conf.	P.29
9	Communication Check	Connection Confir. List	Displays the current operation status of the Central control addresses 1 to 128.	P.31
		Communication Quality	Displays the Communication Quality.	P.31
10	Register Contact Info	Contact TEL No.	Enter the contact information (service store telephone number) for when an error occurs.	P.32
11	ALL Unit ON/OFF Setting		Switches the target for simultaneous ON / OFF.	P.33
12	Air to Water Setting		Switches the target Air to Water Heat Pump unit for ON / OFF.	P.33

Register/Check Indoor Unit (Address Settings)

Address Settings
1. Obtain Address
2. Address Display
3. Address Auto-setting

1 Select "Address Settings" on the "Servicing Menu" screen and press [●] (Confirm)

The "Address Settings" screen appears.

2 Press [^] and [v] to select the item, then press [●] (Confirm)

The screen of the selected item appears.

Obtain Address

Register the indoor unit to the unit.

◆ If you will not change the Central control address

Set the Central control address with the local remote controller in advance.

If you will change the Central control address with the central controller, see "To change the Central control address (P.18)".

Obtain Address
Obtain the address?
Yes
No

1 Select "Obtain Address" on the "Address Setting" screen and press [●] (Confirm)

The "Obtain Address" confirmation screen appears.

2 Press [^] and [v] to select "Yes", then press [●] (Confirm)

"Obtaining address... ⌚ " appears, and after a while, the "Indoor unit list" screen appears.

- This operation will take several minutes.
- On the "Obtain Address" confirmation screen, press [↵] (Return) or select "No" and press [●] (Confirm) to return to the "Address Settings" screen.

Indoor unit list screen

Obtain Address	(1/2)	↑↓	Next
001-006	006	001-014	014
001-007	007	001-015	015
001-008	008	001-016	016
001-009	009	001-017	017
001-010	010	001-018	018
001-011	011	001-019	019
001-012	012	001-020	020
001-013	013	001-021	021

3 On the "Indoor unit list" screen, check that there is no error in the number of connected units and the displayed address, then press [↵] (Return)

The "Address Confirm" confirmation screen appears.

- Press [^] and [v] or [↑↓] (Control) to switch pages.

Obtain Address	(1/2)	↑↓	Next
Confirm	this address?		
Yes			
No			
001-012	012	001-020	020
001-013	013	001-021	021

4 Press [^] and [v] to select "Yes", then press [●] (Confirm)

After the "Address Settings ⌚ " screen, return to the "Servicing Menu" screen.

This completes "Obtain Address".

- Select "No" and press [●] (Confirm) to return to the "Servicing Menu" screen without registering indoor units.

◆ To change the Central control address

Address Settings
1. Obtain Address
2. Address Display
3. Address Auto-setting

Obtain Address
Obtain the address?
Yes
No

Indoor unit list screen

Obtain Address	(1/2)	Hit	Next
001-006	006	001-014	014
001-007	007	001-015	015
001-008	008	001-016	016
001-009	009	001-017	017
001-010	010	001-018	018
001-011	011	001-019	019
001-012	012	001-020	020
001-013	013	001-021	021

Central control address list screen

Obtain Address	(1/2)	Hit	Next
001-006			
001	002	003	004
005	006	007	008
009	010	011	012
013	014	015	016
017	018	019	020
021	022	023	024
025	026	027	028
029	030	031	032
● Confirm			

Obtain Address	(1/2)	Hit	Next
Confirm			
this address?			
Yes			
No			
001-012	012	001-020	020
001-013	013	001-021	021

1 Select "Obtain Address" on the "Address Settings" screen and press [●] (Confirm)

The "Obtain Address" confirmation screen appears.

2 Press [▲] and [▼] to select "Yes", then press [●] (Confirm)

"Obtaining address... ⌚ " appears, and after a while, the "Indoor unit list" screen appears.

- This operation will take several minutes.
- On the "Obtain Address" confirmation screen, press [↵] (Return) or select "No" and press [●] (Confirm) to return to the "Address Settings" screen.

3 Press [←] [▲] [▼] [→] to select the indoor unit whose Central control address you want to change, then press [●] (Confirm)

The "Central control address list" screen appears.

- In the screen, black is "cursor" and grey is "assigned Central control address".
- The Central control address can be set within the following range.
Models that support TU2C-LINK: 1 to 128
Models that do not support TU2C-LINK: 1 to 64

4 Press [←] [▲] [▼] [→] to select the Central control address, then press [●](Confirm)

Return to the "Indoor Unit List" screen.

5 After changing the Central control address, press [↵] (Return) on the "Indoor Unit List" screen

The "Address Confirm" confirmation screen appears.

6 Press [▲] and [▼] to select "Yes", then press [●] (Confirm)

"Registering the address... ⌚ " → "Obtaining address... ⌚ " appears and the display returns to the "Indoor Unit List" screen.

- This operation will take several minutes.
- Select "No" and press [●] (Confirm) to return to the "Servicing Menu" screen without registering the changed address.

7 Check that the displayed address is the address changed in steps 3 to 4, and press [↵] (Return)

The "Address Confirm" confirmation screen appears.

8 Press [▲] and [▼] to select "Yes", then press [●] (Confirm)

After the "Address Settings ⌚ " screen, return to the "Servicing Menu" screen.

This completes "Obtain Address".

- This operation will take several minutes.

Address Display

The indoor units registered in the unit are displayed.

Address Settings
1. Obtain Address
2. Address Display
3. Address Auto-setting

1 Select "Address Display" on the "Address Settings" screen and press [●] (Confirm)

The "Address Display" confirmation screen appears.

Address Display (1/4)			
001-001	002	002-004	008
001-002	001	003-001	017
001-003	003	003-002	018
001-004	004	003-003	019
001-010	010	003-004	020
002-001	005	003-005	021
002-002	006	003-006	022
002-003	007	003-007	023

2 Press [▲] and [▼] to select "Yes", then press [●] (Confirm)

The "Address Display" screen appears.

- Press [▲] and [▼] to switch pages.

Address Auto-setting

The Central control address of the connected indoor units is automatically set from 1 in ascending order of the line address-indoor address.

IMPORTANT

All currently set Central control addresses are overwritten.

Address Settings
1. Obtain Address
2. Address Display
3. Address Auto-setting

1 Select "Address Auto-setting" on the "Address Settings" screen and press [●] (Confirm)

The "Address Auto-setting" confirmation screen appears.

Address Auto-setting
Use auto address settings?
Yes
No

2 Press [▲] and [▼] to select "Yes", then press [●] (Confirm)

The display shifts from "Registering the address... ⌛" to "Address Settings ⌛", and the process is complete when the "Servicing Menu" screen appears.

- This operation will take several minutes.

NOTE

- At initial startup or when "Zone Settings" is not set, when "Obtain Address" is performed, the connected indoor units are set to "ZONE-1" up to 64 units in ascending order of line address. The 65th and subsequent units are not set. If you wish to monitor and control 65 or more units, use another Central Remote Controller to perform "Zone Settings".
- If you change the address from the local remote controller or register the wrong Central control address in the Central Remote Controller, normal operation will not be possible. Perform "Obtain Address" again.
- Devices that set the Central control address with DIPSW cannot change the Central control address from the Central Remote Controller. Configure the settings beforehand so that they do not overlap with other devices.

Change the Zone to which the Indoor Unit Belongs (Zone Settings)

Zone Settings	
1. Central control Address	
2. Line Address	
3. Delete zone setting	

1 On the "Servicing Menu" screen, select "Zone Settings" and press [●] (Confirm)

The "Zone Settings" screen appears.

- The indoor unit list display can be selected from the Central control address order or the Central control address order.

◆ When Central control address is selected

Zone Settings <64> (1/4) ↑↓ Next			
001	1	009	1
002	1	010	1
003	1	011	3
004	1	012	3
005	2	013	10
006	2	014	10
007	2	015	10
008	2	016	10

2 Select "Central control address" using [^] and [v] then press [●] (Confirm)

The "Address list" screen appears.

- Press [↑↓] (Control) to go to the next page.

3 Press [<] [^] [v] [>] to select the address, then press [●] (Confirm)

The "Zone list" screen appears.

Zone Settings <64> (1/4) ↑↓ Next			
001	1	009	1
002	1	010	1
003	1	011	3
004	1	012	3
005	2	013	10
006	2	014	10
007	2	015	10
008	2	016	10

001-002 001				
1	2	3	4	5
6	7	8	9	10
Del		●Confirm		

4 Press [<] [^] [v] [>] to select a zone No., then press [●] (Confirm)

The display returns to the "Address List" screen.

- The selected zone No. appears to the right of the address.
- The number inside < > is the number of units for which the zone No. is set.
- Up to 64 units can be set.
- Air conditioners and Air to Water Heat Pump cannot be set in the same zone.
- If there is both a water temperature control unit and a room temperature control unit, set them in different zones.
If they are set in the same zone, it will not be possible to apply batch settings by zone or to set the temperature based on a schedule.

To Change the Group Zone of Multiple Indoor Units

◆ When "Central control Address" is selected

Zone Settings <64> (1/8) †† Next			
001	1	009	2
002	1	010	2
003	1	011	2
004	1	012	2
005	1	013	2
006	1	014	2
007	1	015	2
008	1	016	2

1 Perform steps 1 to 2 in "Change the Zone to which the Indoor Unit Belongs" (P.20).

The "Address List" screen is displayed.

- You can set either "Central control Address" or "Line Address".

2 Put the cursor on the first address, and then press [≡] (Menu) and [●] (Confirm) at the same time.

Multiple units are selected.

- If you press [↵] (Return), the selection of multiple units is cancelled, and the cursor returns to the first address.

Zone Settings <64> (1/8) †† Next			
001	1	009	2
002			2
003			2
004			2
005			2
006			2
007			2
008	1	016	2

001 ~ 009

1	2	3	4	5
6	7	8	9	10

Del ● Confirm

3 Select the last address by using [<], [^], [v], and [>], and then press [●] (Confirm).

The "Zone List" screen is displayed.

Zone Settings <64> (1/8) †† Next			
001	5	009	5
002	5	010	2
003	5	011	2
004	5	012	2
005	5	013	2
006	5	014	2
007	5	015	2
008	5	016	2

4 Select a zone number by using [<], [^], [v], and [>], and then press [●] (Confirm).

The "Address List" screen returns.

- The selected zone no. is displayed to the right of the address.
- The number in < > is the number of units for which the zone No. is set.
- You can make the settings for up to 64 units.
- An error screen is displayed if you set 65 or more units.

Set the indoor unit as being out of the scope of management.

Zone Settings <64> (1/4) ↑↓ Next			
001	1	009	1
002	001-002 001		1
003			3
004	1	2	3
005	6	7	10
006	Del	•Confirm	10
007			10
008	2	016	10

On the "Zone List" screen, select "Del" then press [●] (Confirm)

The display returns to the "Address List" screen.

- The zone number is deleted and will not be included in the number of units on the All screen.

Delete zone setting

IMPORTANT

After "Delete zone setting", the number of controlled/monitored units will be 0. Reset any zone.

Delete zone setting
Delete all.
Is it OK?
Yes
No

1 On the "Zone Settings" screen, select "Delete zone setting" then press [●] (Confirm)

The "Delete zone setting" confirmation screen appears.

2 Press [▲] and [▼] to select "Yes", then press [●] (Confirm)

"It has been deleted" appears and the display returns to the "Zone Settings" screen.

Changing the Display Method (Display settings)

Display settings
1. Daylight-saving
2. Temperature Display Conf.
3. Unit Order Settings

- 1 On the "Servicing Menu" screen, select "Display settings" then press [●] (Confirm)**

The "Display settings" screen appears.

- 2 Select an item with [^] and [v] then press [●] (Confirm)**

The screen for the selected item appears.

Daylight-saving

Daylight-saving
● Enable
Void

- 1 On the "Display settings" screen, select "Daylight-saving" then press [●] (Confirm)**

The "Daylight-saving" screen appears.

- 2 Select "Enable" or "Void" using [^] and [v] then press [●] (Confirm)**

Press [↵] (Return) to return to the "Display settings" screen.

- When "Void" is set, the clock setting "Daylight-saving" is hidden.

Temperature Display Conf.

Temperature Display Conf.
1. Temp. Unit <°C>
2. Temp. Increments <1°C>

- 1 On the "Display settings" screen, select "Temperature Display Conf." then press [●] (Confirm)**

The "Temperature Display Conf." screen appears.

- 2 Press [^] and [v] to select the item, then press [●] (Confirm)**

The screen for the selected item appears.

◆ Temp. Unit

Temp. Unit
● °C
°F

- 3 Press [^] and [v] to select the temperature unit, then press [●] (Confirm)**

The temperature unit is set.

- Press [↵] (Return) to return to the "Temperature Display Conf." screen.
- The Air to Water Heat Pump cannot display temperature in Fahrenheit.

◆ Temp. Increments

Temp. Increments
● 1°C
0.5°C

- 3 Press [^] and [v] to select the temperature resolution, then press [●] (Confirm)**

The temperature resolution is set.

- Press [↵] (Return) to return to the "Temperature Display Conf." screen.
- The Air to Water Heat Pump cannot display temperature as 0.5 °C.

Unit Order Settings

Set the display order of indoor units on the "Unit" screen.

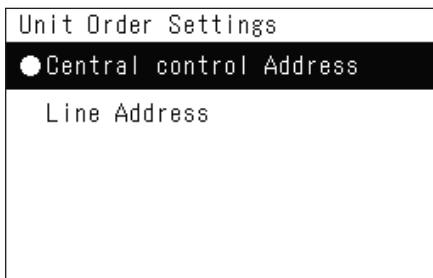

1 On the "Display settings" screen, select "Unit Order Settings" then press [●] (Confirm)

The "Unit Order Settings" screen appears.

2 Press [^] and [v] to select the display order, then press [●] (Confirm)

The display order changes to the selected display order.

- Press [↵] (Return) to return to the "Display settings" screen.

NOTE

Central control address: The indoor units are arranged in ascending order of Central control address, and the numbers display the Central control address.

Line address: The indoor units are arranged in ascending order of line address, and the numbers display the serial number.

Delete the History and Set the Notice Code (Check/Notice Settings)

Check/Notice Settings
1. Delete check history
2. Notice Settings

1 On the "Servicing Menu" screen, select "Check/Notice Settings" then press [●] (Confirm)

The "Check/Notice Settings" screen appears.

2 Press [▲] and [▼] to select the item, then press [●] (Confirm)

The screen for the selected item appears.

Delete check history

Delete check history
Delete all.
Is it OK?
Yes
No

1 On the "Check/Notice Settings" screen, select "Delete check history" then press [●] (Confirm)

The "Delete check history" confirmation screen appears.

2 Press [▲] and [▼] to select "Yes", then press [●] (Confirm)

"It has been deleted" appears and the display returns to the "Check/Notice Settings" screen.

ON/OFF Settings

Notice Settings
1. ON/OFF Settings
2. Delete Notice history

1 On the "Check/Notice Settings" screen, select "Notice Settings" then press [●] (Confirm)

The "Notice Settings" screen appears.

2 Press [▲] and [▼] to select "ON/OFF Settings", then press [●] (Confirm)

The "ON/OFF Settings" screen appears.

ON/OFF Settings	(1/8)	††	Next
● 001	008	016	024
● 002	009	017	025
● 003	010	018	026
● 004	011	019	027
● 005	012	020	028
● 006	013	021	029
● 007	014	022	030
	015	023	031

3 Press [▲] and [▼] to select the notice code to display, then press [●] (Confirm)

"●" is displayed in the selected notice code.

- Press [●] (Confirm) to select/cancel "●".
- Use [††] (Control) to switch pages.
- Press [↵] (Return) to return to the "Notice Settings" screen.

Delete Notice history

Delete Notice history
Delete all.
Is it OK?
Yes
No

1 On the "Notice Settings" screen, select "Delete Notice history" then press [●] (Confirm)

The "Delete Notice history" confirmation screen appears.

2 Press [▲] and [▼] to select "Yes", then press [●] (Confirm)

"It has been deleted" appears and the display returns to the "Notice Settings" screen.

Changing the External Input Function (External Input Settings)

External Input Settings
1. DI1:OFF
2. DI2:ON
3. DI3:Void

DI1Select function(1/2) †† Next
Void
<input checked="" type="radio"/> OFF
ON
Emergency system
Night Operation

DI1Select function(2/2) †† Next
Locking <0>
Thermo OFF
Power peak cut <0%>

DI1Select signal †† Next
<input checked="" type="radio"/> Contact A
Contact B

DI1Select Zone †† End	
<input checked="" type="radio"/> ZONE-1	<input type="radio"/> ZONE-6
<input type="radio"/> ZONE-2	<input type="radio"/> ZONE-7
<input type="radio"/> ZONE-3	<input type="radio"/> ZONE-8
<input type="radio"/> ZONE-4	<input type="radio"/> ZONE-9
<input type="radio"/> ZONE-5	<input type="radio"/> ZONE-10

- 1 On the "Servicing Menu" screen, select "External Input Settings" then press [●] (Confirm)**
The "External Input Settings" screen appears.
- 2 Press [^] and [v] to select the input terminal to set then press [●] (Confirm)**
The "Select function" screen appears.
- 3 Select the function with [^] and [v], press [●] (Confirm), then press [††] (Control) to go to the next screen**
The "Select signal" screen appears.

 - It is necessary to set the control contents for "Locking" and "Power peak cut".
 - When "Void" is set, the display returns to the "External Input Settings" screen.





Lock pattern †† Next
<input checked="" type="radio"/> 0:OFF/-
1:OFF/Unlock1
2:OFF, Lock1/Unlock1
3:OFF/ON

Power peak cut †† Next
80%
70%
60%
<input checked="" type="radio"/> 0%

- 4 Select the input signal with [^] and [v], press [●] (Confirm), then press [††] (Control) to go to the next screen**
The "Select Zone" screen appears.
- 5 Press [<] [^] [v] [>] to select the target zone, then press [●] (Confirm)**
Press [●] (Confirm) to select/cancel "●".

 - In the initial setting, all zones are selected.
 - Zones where indoor units are not registered are not displayed.
- 6 Select the target zones and press [††] (Control)**
The settings are completed and the display returns to the "External Input Settings" screen.

External input function table

Icon	Setting Items	Description	Settings
-	Void	No function	-
-	OFF	When ON, the air conditioners in the specified zones are stopped.	Contact A (ON at signal input, OFF at release) Contact B (OFF at signal input, ON at release)
-	ON	When ON, the air conditioners in the specified zones are operated.	Contact A (ON at signal input, OFF at release) Contact B (OFF at signal input, ON at release)
	Emergency system	When ON, the air conditioners in the specified zones are stopped and the local remote controller is disabled. When OFF, the disabling the local remote controller is released.	Contact A (ON at signal input, OFF at release) Contact B (OFF at signal input, ON at release)
	Night Operation	Reduces the operating noise of the outdoor units.	Contact A (ON at signal input, OFF at release) Contact B (OFF at signal input, ON at release)
	Locking	When ON, the air conditioners in the specified zones are controlled to the set pattern. * Set the lock pattern before setting the input signal.	Contact A (ON at signal input, OFF at release) Contact B (OFF at signal input, ON at release) Pattern 0: Stop when ON, do nothing when OFF Pattern 1: Stop when ON, "Operate/Stop" when OFF Release disabling Pattern 2: Stop when ON, "Operate/Stop" Disabling "Operate/Stop" when OFF Release disabling Pattern 3: Stop when ON, Operate when OFF
	Thermo OFF	When ON, the air conditioners in the specified zones are demand controlled.	Contact A (ON at signal input, OFF at release) Contact B (OFF at signal input, ON at release)
	Power peak cut	When ON, the air conditioners in the specified zones are demand controlled. * Set the demand rate before setting the input signal.	Contact A (ON at signal input, OFF at release) Contact B (OFF at signal input, ON at release) Demand rate (0%/60%/70%/80%)

NOTE

- The icon for each function is displayed at the top of the clock when a signal is received.

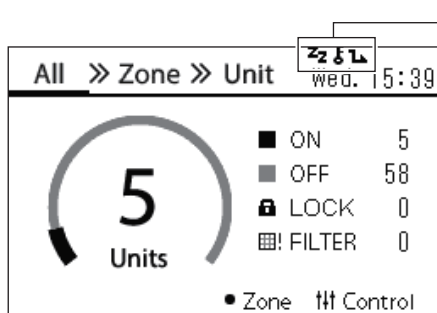

From the left, the icons of the functions assigned to DI1, DI2, and DI3 are displayed.

- When Night Operation is set, turn on the Silent Mode setting of the Hydro Unit to operate the Air to Water Heat Pump.

Switch Operation Mode (CRC Mode Change Conf.)

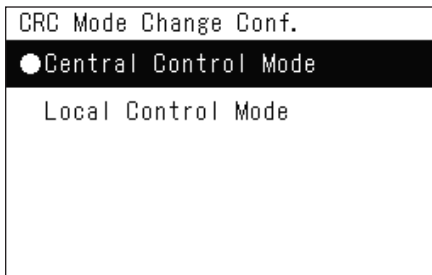

1 On the "Servicing Menu" screen, select "CRC Mode Change Conf." then press [●] (Confirm)

The "CRC Mode Change Conf." screen appears.

2 Press [^] [v] to select the mode, then press [●] (Confirm)

Press [↵] (Return) to return to the "Servicing Menu" screen.

NOTE

Central Control Mode: Use this unit as a Central Remote Controller.

By setting the "Key lock" on this unit, you can restrict the operation of the local remote controller.

Local Control Mode: Use this unit as a remote controller.

When "Key lock" is set by another Central Remote Controller, the operation of this unit is restricted in the same way as the local remote controller.

While Local Control Mode is set,  appears at the top of the clock and on each control screen.

Change the Indoor Unit Data (DN setting)

IMPORTANT

Only service personnel should perform this work.

Do not change this as it is related to the control of the device.

Change Communication Configuration (Communication Conf.)

1 On the "Servicing Menu" screen, select "Communication Conf." then press [●] (Confirm)

The "Communication Conf." screen appears.

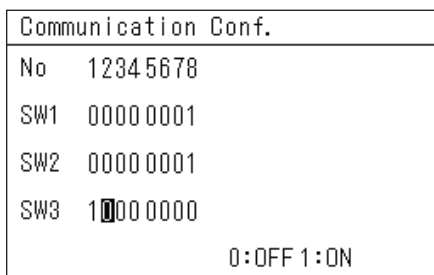
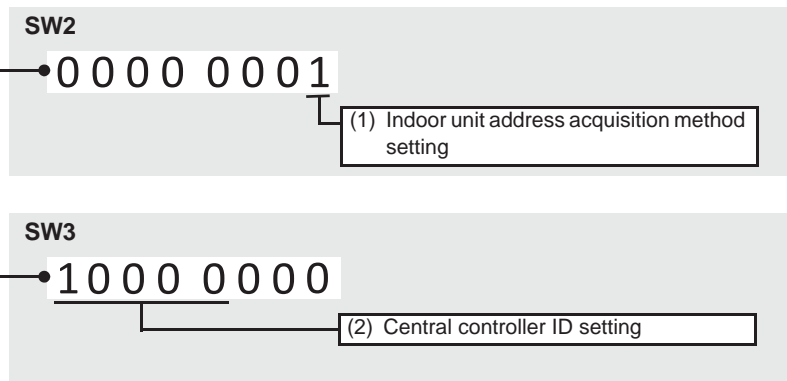
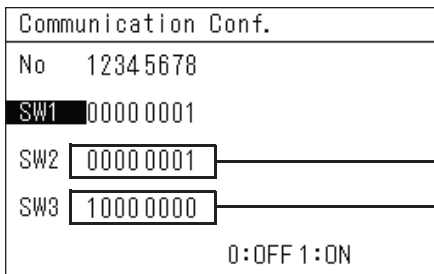

2 Press [▲] and [▼] to select the SW number, then press [←] and [→] to move the cursor to the switch you want to change

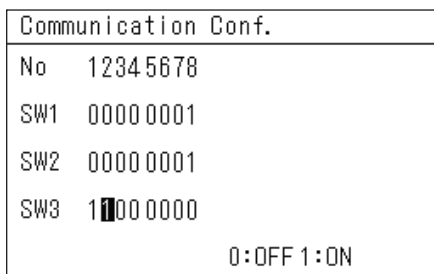

3 Press [▲] [▼] to change the value, then press [●] (Confirm)

The data is confirmed and the display returns to the "Servicing Menu" screen.

- To change multiple values, change all switches then press [●] (Confirm).

NOTE

For details of Communication Configuration, refer to the next page.
Do not change any settings other than (1) and (2).

(1) Indoor unit address acquisition method setting

0: Line address mode

1: Central control address mode

(2) Central controller ID setting**When using in combination**

- When using 2 or more units in combination with this Central Remote Controller only
Set the Central controller ID numbers for the second and subsequent units to Central controller ID 2 and subsequent ID numbers.
Example: When using 3 units in combination
1st unit: Central controller ID 1 (initial setting)
2nd unit: Central controller ID 2
3rd unit: Central controller ID 3
- When using in combination with a central control device that supports TU2C-LINK
Set to Central controller ID 2 or a subsequent ID number so that it does not overlap with other central control devices.
- When using in combination with a central control device that does not support TU2C-LINK
Set to "Old controller".

When replacing with a Central Remote Controller that does not support TU2C-LINK

If only 1 unit is used (no combined use), use the initial settings.

When using more than 1 unit, set according to "When using in combination".

Central controller ID	SW3 1234 5
Central controller ID 1 (initial value)	1000 0
Central controller ID 2	0100 0
Central controller ID 3	1100 0
Central controller ID 4	0010 0
Central controller ID 5	1010 0
Central controller ID 6	0110 0
Central controller ID 7	1110 0
Central controller ID 8	0001 0
Central controller ID 9	1001 0
Central controller ID 10	0101 0
Central controller ID 11	1101 0
Central controller ID 12	0011 0
Central controller ID 13	1011 0
Central controller ID 14	0111 0
Central controller ID 15	1111 0
Central controller ID 16	0000 1
Central controller ID 17	1000 1
Central controller ID 18	0100 1
Central controller ID 19	1100 1
Central controller ID 20	0010 1
Old controller (TCC-LINK controller)	1111 1

IMPORTANT

- If you set the address acquisition method to "Line address mode", it will take time to obtain the address.
- Do not set the Central controller ID to a value other than the values shown in the list.
- If the setting is incorrect, a communication error may occur.
- Unless using it together with another central control device other than this device, there is no need to set the central controller ID.
- If there is another central control device (of the U series) other than this device, perform central controller ID setting so that there is no duplication of ID numbers. If there is any duplication of central controller IDs, the check code S33 will appear.
- If there is another central control device (not of the U series) other than this device, select "Old controller" for the setting.

Check the Connection Status of the Indoor Units (Communication Check)

Communication Check	
1. Connection Confir. List	
2. Communication Quality	

1 On the "Servicing Menu" screen, select "Communication Check" then press [●] (Confirm)
The "Communication Check" screen appears.

2 Press [▲] and [▼] to select the item, then press [●] (Confirm)
The screen for the selected item appears.

Connection Confir. List

Connection Confir. List (1/8)					
001	1	ON	009	1	🔒
002	1	ON	010	1	🔒
003	1	ON	011	3	OFF
004	1	ON	012	3	ON
005	2	OFF	013	10	🚫
006	2	OFF	014	10	🚫
007	2	OFF	015	10	⚠️
008	2	OFF	016	10	⚠️

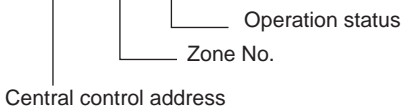

1 On the "Communication Check" screen, select "Connection Confir. List" then press [●] (Confirm)
The "Connection Confir. List" screen appears.

2 Press [▲] and [▼] to switch pages

- Press [↵] (Return) to return to the "Communication Check" screen.
- The Central control addresses are displayed in ascending order.
- Central control addresses fields that are not connected will be blank.

Communication Quality

Communication Quality						
Ux	Laddr	n	U%	R%	X%	bps
Uh	-	0	3	5	0	9600
Uv	001	0	-	-	-	-

1 On the "Communication Check" screen, select "Communication Quality" then press [●] (Confirm)
The "Communication Quality" screen appears.

2 Press [▲] and [▼] to switch pages

- Press [↵] (Return) to return to the "Communication Check" screen.

Item	Description
Ux	Uh: Between lines, Uv: Within lines
Laddr	Line address
n	Number of connected units
U%	Usage rate
R%	Retransmission rate
X%	Collision rate
bps	Communication baud rate

Register Contact Information when an Error Occurs (Register Contact Info)**Contact TEL No.**

Register Contact Info
1. Contact TEL No.

Contact TEL No.
Input telephone number
■-----

- 1 On the "Servicing Menu" screen, select "Register Contact Info" then press [●] (Confirm)**
The "Register Contact Info" screen appears.
- 2 Select "Contact TEL No." with [^] and [v] then press [●] (Confirm)**
The "Contact TEL No." screen appears.
- 3 Move the cursor with [<] and [>], select a number with [^] and [v], then press [●] (Confirm)**
The contact TEL No. is registered and the display returns to the "Register Contact Info" screen.

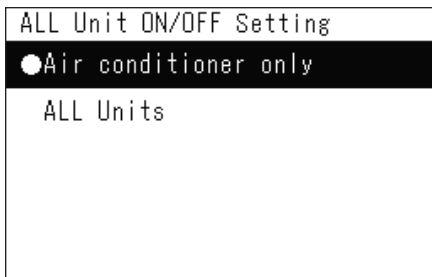
ALL Unit ON/OFF Setting

- 1 On the "Servicing Menu" screen, select "ALL Unit ON/OFF Setting" then press [●] (Confirm)**

The "ALL Unit ON/OFF Setting" screen appears.

- 2 Press [^] and [v] to select the item, then press [●] (Confirm)**

Press [↵] (Return) to return to the "Servicing Menu" screen.

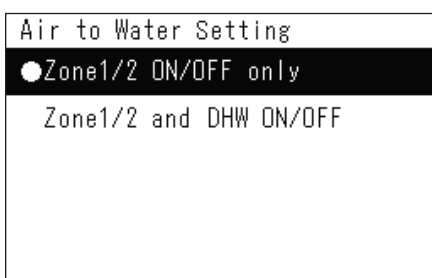
Air to Water Setting

- 1 On the "Servicing Menu" screen, select "Air to Water Setting" then press [●] (Confirm)**

The "Air to Water Setting" screen appears.

- 2 Press [^] and [v] to select the item, then press [●] (Confirm)**

Press [↵] (Return) to return to the "Servicing Menu" screen.

Owner's Manual

For commercial use

Central remote controller TU2C-LINK/TCC-LINK compatible

Model name

TCB-SC640U-E
TCB-SC640U-TR
TCB-SC640U-ME



Multilingual installation manuals and owner's manual



[Български] Изтегляне на Ръководство за монтаж и Ръководство на потребителя / [Česky] Stažení Instalační příručky a Uživatelské příručky / [Dansk] Download af installationsvejledning og brugervejledning / [Deutsch] Installationshandbuch und Bedienungsanleitung herunterladen / [Ελληνικά] Λήψη εγχειριδίου εγκατάστασης και εγχειριδίου κατόχου / [English] Installation manual and Owner's manual Download / [Español] Descarga del Manual de instalación y del Manual del propietario / [Eesti] Paigaldusjuhendi ja kasutusjuhendi allalaadimine / [Suomi] Asennusohjeiden ja käyttöohjeiden lataaminen / [Français] Téléchargement du manuel d'installation et du manuel du propriétaire / [Hrvatski] Preuzimanje Instalacijskog priručnika i Vlasničkog priručnika. / [Magyar] Telepítési kézikönyv és Felhasználói kézikönyv letöltése / [Italiano] Download del Manuale di installazione e del Manuale dell'utilizzatore / [] / [Latviešu] Uzstādīšanas rokasgrāmatas un lietotāja rokasgrāmatas lejupielāde / [Norsk] Nedlasting av installasjonsveiledning og bruksanvisning / [Nederlands] Installatiehandleiding en Handleiding downloaden / [Polski] Pobieranie Instrukcji instalacyjnej oraz Instrukcji użytkownika / [Português] Download do Manual de instalação e Manual do Proprietário / [Română] Descărcarea Manualului de instalare și a Manualului proprietarului / [Русский] Скачать Руководство по установке и Руководство пользователя / [Slovensky] Stiahnutie Montážnej príručky a Uživatelskej príručky / [Slovenščina] Prenos navodil za montažo in navodil za uporabo / [Svenska] Nedladdning av installationshandbok och bruksanvisning / [Türkçe] Kurulum kılavuzu ve Kullanıcı kılavuzu İndirme / [中文] 安装手册和用户手册下载 / [عربی] دليل التثبيت ودليل المالك تنز بل

<https://www.toshiba-carrier.co.jp/global/manual/tcb-sc640u.htm>

- Thank you for purchasing this central control device.
- In order to use this product safely and correctly, please read this operation manual carefully before use and make sure that you fully understand the contents.
In particular, please be sure to read the "Safety Precautions".
- After reading this manual, be sure to keep it in a place where the operator of the Unit can always view it.

Contents

1	Quick Start Guide	4
1-1.	Air conditioner	4
1-2.	Air to Water Heat Pump	4
2	Safety Precautions	5
3	Before Usage	7
	System Configurations	7
	Names and Functions of Each Part	8
	Operation Panel Part	8
	Icon List (Air conditioner)	9
	Icon List (Air to Water Heat Pump)	10
	LCD Display Part (Common)	11
	LCD Display Part (Air conditioner)	12
	LCD Display Part (Air to Water Heat Pump)	14
	Changing Screens (Air conditioner)	15
	Changing Screens (Air to Water Heat Pump)	16
	Setting the Clock (Clock)	17
	Changing the First Day of the Week (First Day)	19
4	Basic Usage	20
4-1.	Air conditioner	20
	Start/Stop Operation	20
	Start/Stop Operation of All air conditioners	20
	Start/Stop Operation of All air conditioners in a Zone	21
	Start/Stop Operation of an Individual air conditioner	22
	Changing air conditioner Settings (Set Temperature, Operation Mode, Fan Speed, and Louver)	23
	Setting the Operating Schedule	24
	Changing the Operating Schedule (Operating Sch Enable/ Void and Operating Sch settings)	26
	Changing the details of the Operating Schedule settings	26
	Copying the Operating Schedule	29
	Deleting the Operating Schedule	30
	Changing the details of the special day schedule settings	31
	Changing the Energy Saving Schedule (Energy Saving Schedule)	32
	Changing the details of the Energy Saving Schedule settings	32
	Copying the Energy Saving Schedule	33
	Deleting the Energy Saving Schedule	34
4-2.	Air to Water Heat Pump	35
	Start/Stop Operation	35
	Start/Stop Operation of All Air to Water Heat Pumps	35

Start/Stop Operation of All Air to Water Heat Pump in a Zone	36
Start/Stop Operation of an Individual Air to Water Heat Pump	37
Changing Air to Water Heat Pump Settings (Set Temperature, Operation Mode)	38
Setting the Operating Schedule	39
Changing the Operating Schedule (Operating Sch Enable/ Void and Operating Sch settings)	41
Changing the details of the Operating Schedule settings	41
Copying the Operating Schedule	44
Deleting the Operating Schedule	45
Changing the details of the special day schedule settings	46
5 Various Functions	47
5-1. Air conditioner	47
Setting the Operation Details	47
Operation after filter cleaning (Filter Sign Reset)	48
Set the ventilation function, ventilation mode, and fan speed (Ventilation)	49
Limit the output of the air conditioner (Energy saving operation)	51
Lock the local remote control operation (Key lock)	52
Make all the louver settings in the group at once (Louver setting in Group)	53
5-2. Air to Water Heat Pump	54
Setting the Operation Details	54
Auto mode	55
Frost protection	55
Anti bacteria	56
Night setback	56
Unit Information	57
6 Administrator Menu	58
Renaming a zone (Zone Name Settings)	58
Changing the screen display (Screen Display Settings)	59
Changing a button operation (Button Settings)	60
Checking the Check / Notice history (Check/Notice history)	62
Changing the administrator password (Admin. Password Settings)	63
Checking the device information (Information)	63
7 Troubleshooting	64
8 Appendix	65
Specifications	65
Function list (Air conditioner)	65
Function list (Air to Water Heat Pump)	66

1 Quick Start Guide

1-1. Air conditioner

Basic Usage	
To start/stop the air conditioner operation	→“Start/Stop Operation” (P.20)
To change the set temperature	→“Changing air conditioner Settings (Set Temperature, Operation Mode, Fan Speed, and Louver)” (P.23)
To change the operation mode (Cool, Heat, Auto, Dry, or Fan)	→“Changing air conditioner Settings (Set Temperature, Operation Mode, Fan Speed, and Louver)” (P.23)

Advanced Usage Please use the following functions as necessary.	
To reserve operation start/stop	→“Setting the Operating Schedule” (P.24)
To cancel the Filter Sign after filter cleaning	→“Operation after filter cleaning (Filter Sign Reset)” (P.48)
To operate the Air to air heat exchanger	→“Set the ventilation function, ventilation mode, and fan speed (Ventilation)” (P.49)
To make energy-saving settings	→“Limit the output of the air conditioner (Energy saving operation)” (P.51)
To restrict the local remote control operation	→“Lock the local remote control operation (Key lock)” (P.52)

1-2. Air to Water Heat Pump





Basic Usage	
To start/stop the Air to Water Heat Pump operation	→“Start/Stop Operation” (P.35)
To change the set temperature	→“Changing Air to Water Heat Pump Settings (Set Temperature, Operation Mode)” (P.38)
To change the operation mode (Cool, Heat)	→“Changing Air to Water Heat Pump Settings (Set Temperature, Operation Mode)” (P.38)

Advanced Usage Please use the following functions as necessary.	
To reserve operation start/stop	→“Setting the Operating Schedule” (P.39)
To restrict the local remote control operation	→“Lock the local remote control operation (Key lock)” (P.52)

2 Safety Precautions

This section explains safety precautions you must follow in order to prevent harm to the user and other persons and damage to property.

“Display Description” explains the classification of the degree of harm or damage that may occur if the unit is handled incorrectly, while “Symbol Description” indicates the meanings of symbols.

Display Description		Symbol Description	
 WARNING	Indicates “Content that is expected to result in death or serious injury (*1) to the user in the case of incorrect handling”.		⊘ indicates prohibited actions. Specifically prohibited contents are indicated with a picture and/or text in or near the symbol.
 CAUTION	Indicates “Content that is expected to result in minor injury (*2) to the user or damage to property (*3) in the case of incorrect handling”.		ⓘ indicates instructions which must be followed. The actual contents of the instructions are indicated with a picture and/or text in or near the symbol.



* 1: Serious injury refers to lasting after effects such as blindness, injury, burns (high temperature / low temperature), electric shock, bone fracture, or poisoning, etc. and injuries that require hospitalization/long-term outpatient treatment.

* 2: Minor injury refers to injuries, burns, or electric shocks, etc. that do not require hospitalization or long-term outpatient treatment.





* 3: Damage to property refers to extended damage related to houses, household goods, livestock, or pets, etc.

⚠ WARNING



Installation Precautions

 Request installation	Ask the dealer from whom you purchased the unit or a professional for installation work. Installation requires specialised technical expertise. If you attempt to perform installation work yourself and perform the work incorrectly, it may cause fire, electric shock, or injury.	 Use specified products	Use a designated TOSHIBA air conditioner. Please use a designated TOSHIBA air conditioner. Using products other than specified may cause fire, electric shock, or water leakage. Also, please ask a professional for installation work.
---	---	---	---

Usage Precautions





 Prohibited	Do not operate the switches with wet hands. Doing so may cause electric shock or failure.	 Prohibited	Do not wet the central control device. Be careful not to get the central control device wet. Doing so may cause fire, electric shock, or failure.
 Compulsory	Turn off the power if anything is abnormal (burnt odour etc.). Continued use may cause fire or electric shock. Please ask the dealer from whom you purchased the product.	 Compulsory	Do not use a power source other than the specified model. Using a power source other than the specified model may cause fire or failure. Please use AC220-240V.

Relocation/Repair Precautions



 Prohibited	Do not remodel. Doing so may cause fire or electric shock.	 Request	Please ask the dealer from whom you purchased the unit for repair. Faulty repair may cause fire or electric shock.
 Request relocation	Contact a specialist or the dealer from whom you purchased the unit to relocate and re-install the air conditioner. Faulty installation may cause fire, electric shock or injury.		

⚠ CAUTION

Installation Precautions

 Check the installation location	<p>Do not install in areas with high humidity or vibration. Doing so may cause a failure.</p>	 Check the installation location	<p>Do not install in direct sunlight or near heat sources. Doing so may cause a failure.</p>
 Check the installation location	<p>Do not install in areas where noise is generated. Doing so may cause malfunction.</p>	 Check the installation location	<p>Do not install this product in a place where combustible gas may leak. Gas leaking and accumulating around the product may cause a fire.</p>
 Check the installation location	<p>Do not use this device in locations where children may be present.</p>		

Usage Precautions

 Prohibited	<p>Do not drop the product or apply strong shock. Doing so may cause a failure.</p>	 If anything is abnormal turn off the power	<p>If this product malfunctions, turn off the original power supply, and then contact the dealer from whom you purchased the product to ask for repair. Continued operation with an abnormality may cause fire or electric shock.</p>
 Instructions	<p>When cleaning and checking, turn off the earth leakage breaker. Failing to do so may cause injury.</p>		

3 Before Usage

System Configurations

The system configurations that this unit can control are as follows:

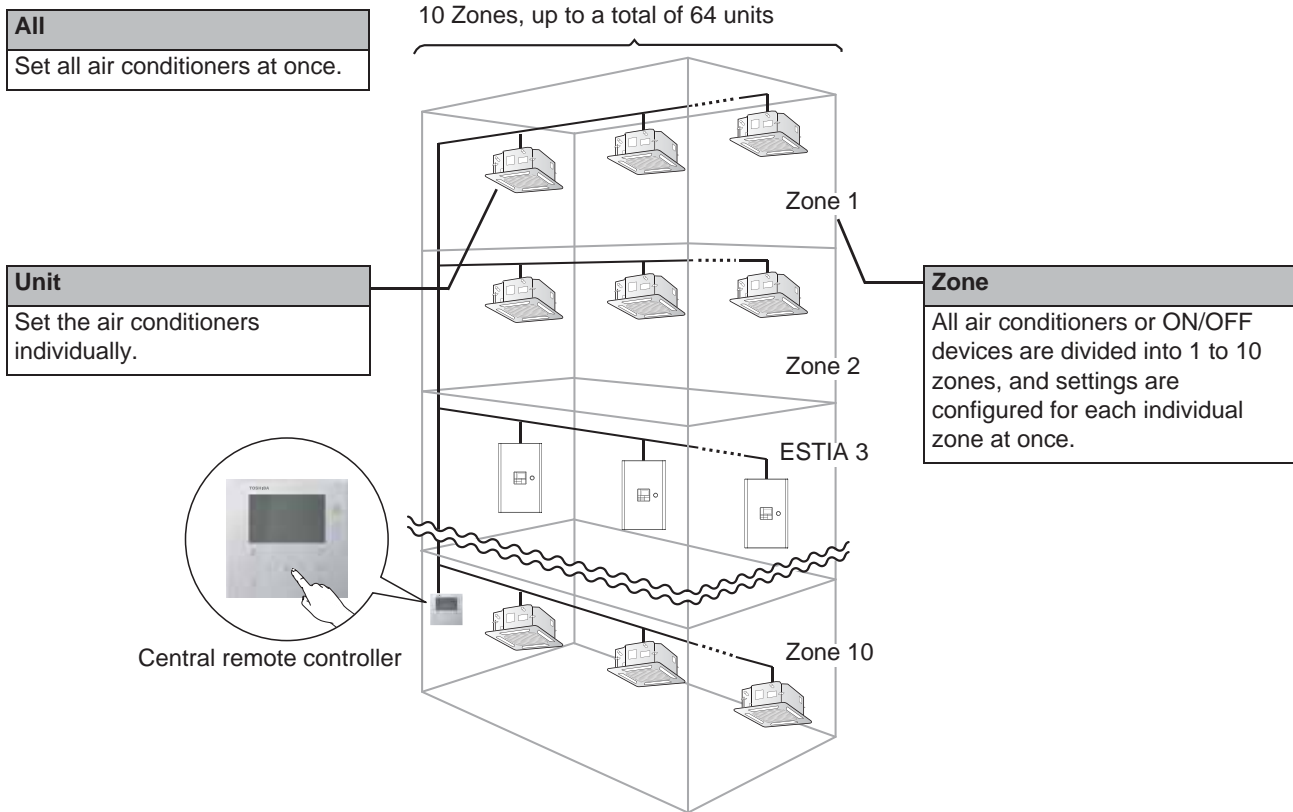

- Control can be exerted in three different units: All, Zone, and Unit.
- Up to 10 zones can be controlled.
- Up to 64 units (air conditioners and ON/OFF devices) can be controlled.
- ON/OFF device: A device whose set temperature and operation mode cannot be controlled or monitored.
The major devices include the light settings, Air to air heat exchanger, and ventilating fan.

Each screen shows a display example. The display content may vary with the usage environment settings.





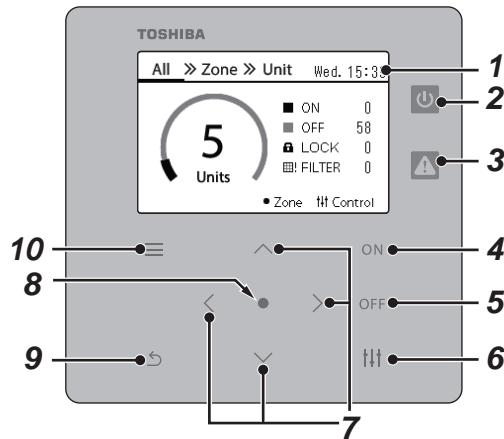













Names and Functions of Each Part

Operation Panel Part















No.	Name	Functions
1	LCD display part (P.11)	
2	Run lamp	Lights up during operation and turns off when stopped. * The Run lamp lights up if any of the air conditioners is operating and turns off when all the air conditioners are stopped.
3	Check lamp	Lights in red if an abnormality occurs. Please contact the dealer from whom you purchased the unit.
4	[ON] button	Press to start operation.
5	[OFF] button	Press to stop operation.
	[↑↓] (Control) button	Press to display the "Control" screen or the "Menu" screen for controlling air conditioners.
	[↖] [↗] [←] [→] buttons	Press to select setting item.
	[●] (Confirm) button	Press when switching screens from All to Zone to Unit, or when selecting an item and going to the next screen.
	[↶] (Return) button	Press to return to the previous screen.
1	[≡] (Menu) button	Press to display the "Settings Menu" screen to configure Unit settings.

Icon List (Air conditioner)

No.	Icon	Description
1		An abnormality is occurring. Check with "Check history" (P.62), and contact the dealer from whom you purchased the product.
2		A notice code is occurring. Check with "Notice history" (P.62).
3		Displayed when it is time to clean the filter. (P.48)
4		Displayed when preparation for heating is in progress.
5		Displayed when preparation for operation is in progress.
		The temperature acquired from the indoor unit is displayed only in the "Control" screen of Unit.
		Displayed when Energy saving operation is set. (P.51)
		Displayed when this unit is set to Local Control Mode.*
		Displayed when the operation of the local remote control connected to each air conditioner is restricted. For details, see "Lock the local remote control operation (Key lock)" (P.52).
1		Displayed when Bypass is set.
11		Displayed when Automatic is set.
12		Displayed when Heat exchange is set.
13		Displayed when a schedule is set.
14		Displayed when the Emergency system signal (external input) is detected.*
15		Displayed when the Power peak cut signal (external input) is detected.*
1		Displayed when the Night operation signal (external input) is detected.*
1		Displayed when the Lock signal (external input) is detected.*
1		Displayed during Daylight-saving.

* Please refer to the installation manual for details.

Icon List (Air to Water Heat Pump)

No.	Icon	Description
1		Lights during hot water supply is selected.
2		Lights during Auto mode operation.
3		Lights while Frost protection operation is actually running.
4		Lights when Anti bacteria operation is set to "ON" and hot water operation is selected.
5		Lights when Night setback operation is set to "ON" and heating or cooling is selected.
		Lights while hot water boost is actually running.
		Lights when the compressor is acting.
		Lights while the electric heater inside the Hydro Unit is energized during a heating operation.
		Lights while the electric cylinder heater is energized during hot water operation.
1		Lights while internal pump 1 is driven.
11		Lights while expansion pump 2 is driven.
12		Lights when the auxiliary boiler or external booster heater supports the heat pump operation.

LCD Display Part (Common)

There are “All”, “Zone”, and “Unit” screens on which you can check the operation status of each area, the “Control” screen on which can control the operation status, and the “Menu” screen for detailed settings.
 For details on how to switch between screens, see “Changing Screens (Air conditioner)” (P.15).

All screen

You can check and control the operation status of all air conditioners that are being monitored and controlled.

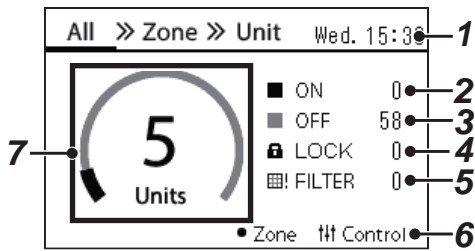

* Before using this device, be sure to set the Clock.

No.	Functions
1	The time set in “Clock” is displayed. An icon is displayed above the clock.
2	The number of air conditioners in operation (including ON/OFF devices) is displayed.
3	The number of stopped air conditioners (including ON/OFF devices) is displayed.
4	The number of air conditioners whose operation is restricted by “Key lock” is displayed.
5	The number of air conditioners with filter cleaning indications is displayed. ⚠: If an abnormality occurs, the display changes to the number of abnormal air conditioners. ⚡: If a notice occurs, the display changes to the number of air conditioners for which the notice has occurred.
	The Button Operation Guide is displayed.
	The number of air conditioners in operation (including ON/OFF devices) is displayed by the ON/OFF meter. The number of air conditioners in operation is indicated by the number on the inside of the ON/OFF meter.

Zone screen

You can check and control the operation status in Zone units. You can also check whether there are any abnormalities and whether filter cleaning is required.

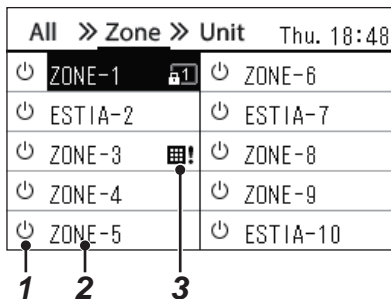

No.	Functions
1	The operation status of the Zone is displayed. If you are driving any air conditioners in the Zone, ⏻ is displayed. If all air conditioners are stopped, ⏻ is displayed.
2	The name of the Zone is displayed.
3	The order of display priority is as follows. Check > Notice > Filter > Lock ⚠: Displayed when there is any abnormal air conditioner. ⚡: Displayed when there is any air conditioner for which a notice has occurred. 🧼!: Displayed when there is an air conditioner that requires filter cleaning. 🔒: Displayed when “Key lock” is set.

LCD Display Part (Air conditioner)

Unit screen

You can check and control the operation status of the air conditioners in each Zone individually. Also, you can check the set temperature and other statuses, as well as whether there are any abnormalities and whether filter cleaning is required.

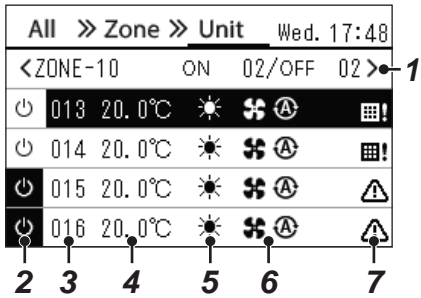

No.	Functions
1	The name of the Zone displayed on the screen and the number of air conditioners in operation/stopped in the Zone are displayed.
2	The operation status is displayed. During operation, is displayed, when stopped, is displayed.
3	The registered devices are displayed in ascending order of central control addresses.
4	The set temperature is displayed.
5	The operation mode is displayed.
	The fan speed is displayed.
	: Displayed when "Key lock" is set. The order of display priority is as follows. Check > Notice > Filter : Displayed for an abnormal air conditioner. : Displayed for an air conditioner for which a notice has occurred. : Displayed when there is an air conditioner that requires filter cleaning.

Control screen

You can check and change the setting contents by All, by Zone, or by Unit. Press [F] (Control) on the "All" screen, "Zone" screen, or "Unit" screen to display each "Control" screen.

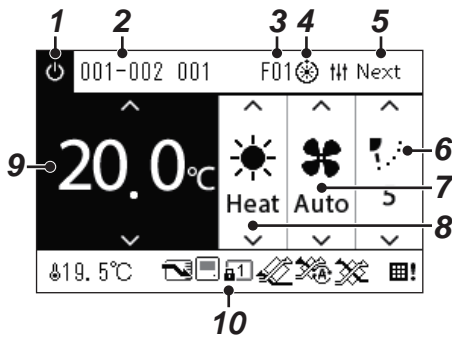

No.	Functions
1	The operation status is displayed. During operation, is displayed, when stopped, is displayed.
2	The currently displayed control range (All, Zone, or Unit Address (Line - indoor central control)) is displayed.
3	If there is an abnormality, a check code is displayed in letters and numbers. If there is a notice, a notice code is displayed as a number. Contact the dealer from whom you purchased the product.
4	Displayed during preparation. : Preparation for operation is in progress. : Preparation for heating is in progress.
5	The Button Operation Guide is displayed.
	You can check and change the louver.
	You can check and change the fan speed. (P.23)
	You can check and change the operation mode. (P.23)
	You can check and change the set temperature. (P.23)
1	The operation status icon is displayed. Also, the Button Operation Guide is displayed when changing the set temperature or any other setting. For the icons that are displayed, see the Icon list (P.9).

◆ When -- is displayed on the Control screen of All or Zone

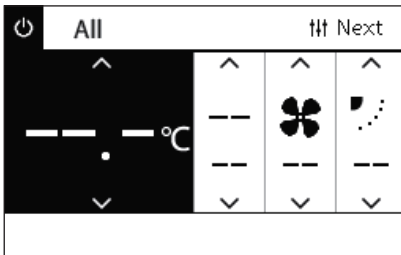

Displayed when the air conditioner settings do not match.

- When you have configured the settings on the “Control” screen of All or Zone but there is an air conditioner whose settings become invalid because there is no corresponding function.
- When you have changed any individual setting using the local remote control after changing the settings on the “Control” screen of All or Zone.
- If you press [●] (Confirm) with “--” displayed, the air conditioner is not set.

◆ When a blank is displayed on the Control screen of Unit

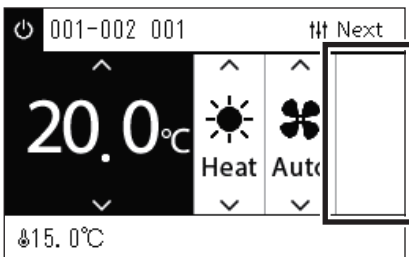

A blank is displayed if there is a function whose settings cannot be changed. The screen shown at the left is an example of the model having a fixed louver. Blank spaces cannot be selected using [<] or [>].

◆ When the following is displayed on the Control screen of Unit

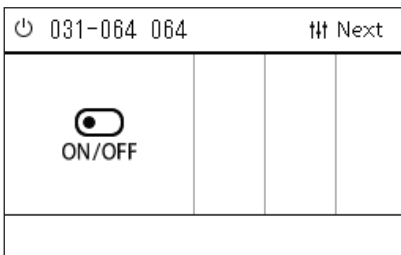

The Air to air heat exchanger or general-purpose device control interface is registered.

The only possible operation is the start/stop operation.

When the Air to air heat exchanger is registered, you can set “Ventilation” in the “Menu” screen.

LCD Display Part (Air to Water Heat Pump)

Please refer to "Changing Screens (Air to Water Heat Pump)" (P.16) for instructions on how to switch between each of the screens.

Unit screen

You can check and control the operating status of Air to Water Heat Pumps within each Zone individually. You can also check other conditions such as the set temperature and the presence or absence of abnormalities.

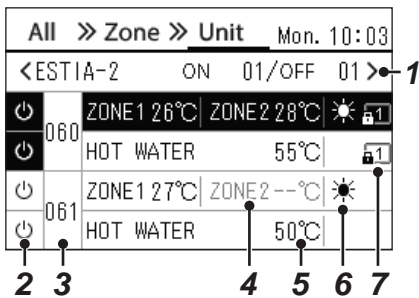

No.	Functions
1	The name of the Zone displayed on the screen and the number of Air to Water Heat Pump in operation/stopped in the Zone are displayed.
2	The operation status is displayed. During operation, is displayed, when stopped, is displayed.
3	The registered devices are displayed in ascending order of central control addresses.
4	If disabled, items will be displayed in gray.
5	The set temperature is displayed.
	The operation mode is displayed.
	The order of display priority is as follows. Check > Lock : Displayed for an abnormal Air to Water Heat Pump. : Displayed when "Key lock" is set.

Control screen

You can check and change the setting contents by All, by Zone, or by Unit. Press [↑↓] (Control) on the "All" screen, "Zone" screen, or "Unit" screen to display each "Control" screen.

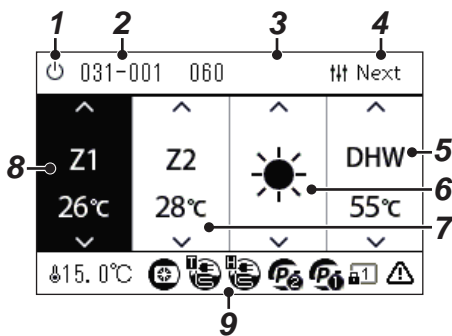

No.	Functions
1	The operation status is displayed. During operation, is displayed, when stopped, is displayed.
2	The currently displayed control range (All, Zone, or Unit Address (Line - indoor central control)) is displayed.
3	If there is an abnormality, a check code is displayed in letters and numbers. Contact the dealer from whom you purchased the product.
4	The Button Operation Guide is displayed.
5	You can check and change the set temperature of Domestic Hot Water (DHW). (P.38)
	You can check and change the operation mode. (P.38)
	You can check and change the set temperature of ZONE2 (Z2).
	You can check and change the set temperature of ZONE1 (Z1).
	The operation status icon is displayed. Also, the Button Operation Guide is displayed when changing the set temperature or any other setting. For the icons that are displayed, see the "Icon list (Air to Water Heat Pump)" (P.10).

Changing Screens (Air conditioner)

To switch between the All, Zone and Unit screens and to display each “Control” screen and “Menu” screen, operate the buttons as follows.

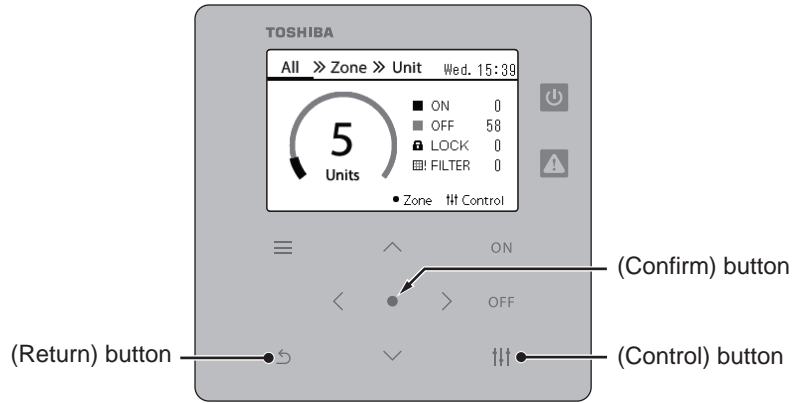

All screen

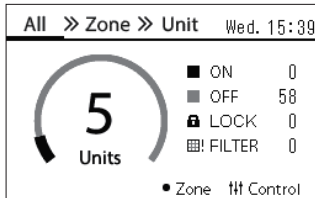

Zone screen

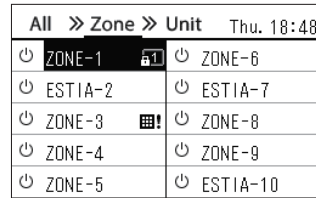

Unit screen

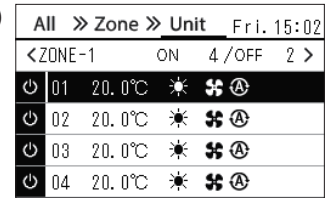

All Control screen

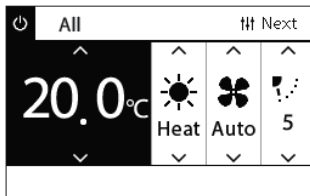

All Menu screen

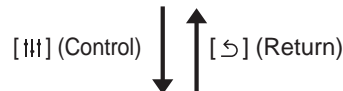
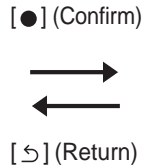
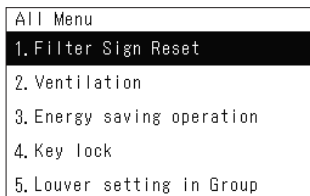

Zone Control screen

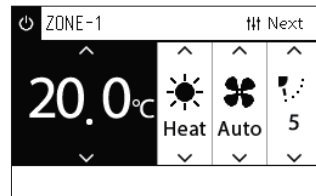

Zone Menu screen

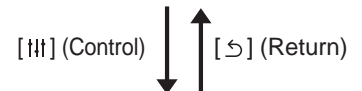
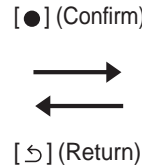
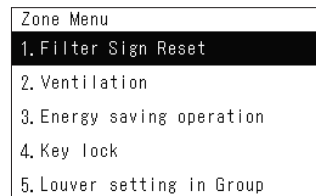

Unit Control screen

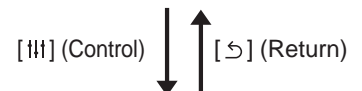
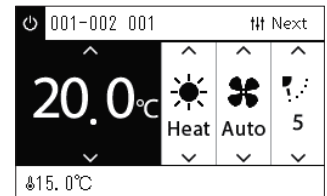

Unit Menu screen

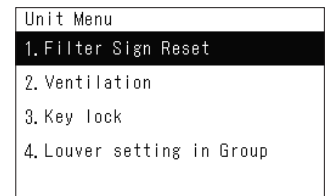

Changing Screens (Air to Water Heat Pump)

To switch between the All, Zone and Unit screens and to display each “Control” screen and “Menu” screen, operate the buttons as follows.

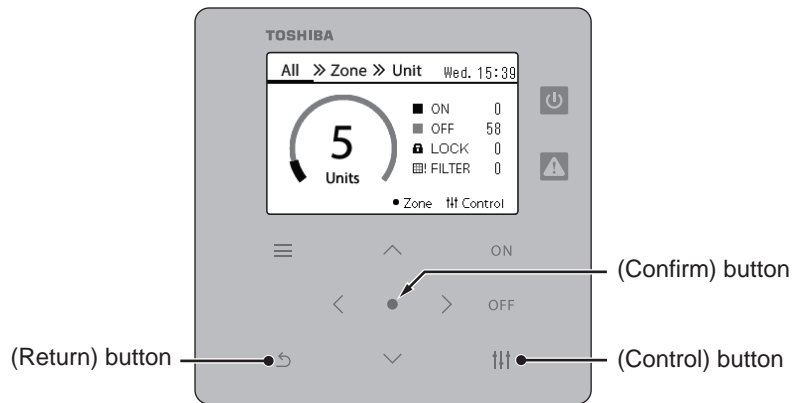

All screen

All >> Zone >> Unit	Wed. 15:39
5 Units	<ul style="list-style-type: none"> ■ ON 0 ■ OFF 58 ■ LOCK 0 ■ FILTER 0
● Zone ⏏ Control	

[●] (Confirm)

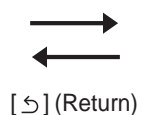

Zone screen

All >> Zone >> Unit	Thu. 18:48
⏏ ZONE-1	⏏ ZONE-6
⏏ ESTIA-2	⏏ ESTIA-7
⏏ ZONE-3	⏏ ZONE-8
⏏ ZONE-4	⏏ ZONE-9
⏏ ZONE-5	⏏ ESTIA-10

[●] (Confirm)

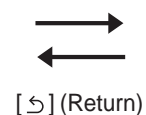

Unit screen

All >> Zone >> Unit	Mon. 14:04
< ESTIA-2	ON 00/OFF 02 >
⏏ 060	ZONE1 26°C ZONE2 28°C ☀
⏏	HOT WATER 55°C
⏏ 061	ZONE1 20°C ZONE2 --°C ☀
⏏	HOT WATER 50°C



All Control screen

⏏ All	⏏ Next
⏏ Z1	⏏ Z2
26°C	28°C
☀	DHW
	55°C

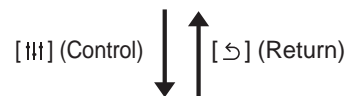

Zone Control screen

⏏ ESTIA-2	⏏ Next
⏏ Z1	⏏ Z2
26°C	28°C
☀	DHW
	55°C

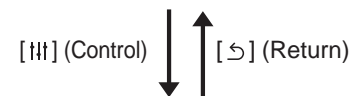

Unit Control screen

⏏ 031-001 060	⏏ Next
⏏ Z1	⏏ Z2
26°C	28°C
☀	DHW
	55°C
● Confirm ↵ Return	



All Menu screen

All Menu(1/2)
1. Key lock
2. Auto mode
3. Frost protection
4. Anti bacteria
5. Night setback

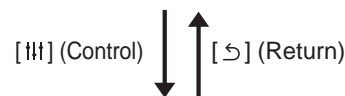

Zone Menu screen

Zone Menu(1/2)
1. Key lock
2. Auto mode
3. Frost protection
4. Anti bacteria
5. Night setback

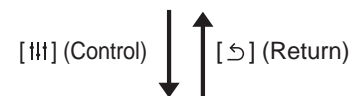

Unit Menu screen

Unit Menu(1/2)
1. Key lock
2. Auto mode
3. Frost protection
4. Anti bacteria
5. Night setback

Setting the Clock (Clock)

• REQUIREMENT

The clock must be set before start using this central remote controller.

If the clock is not set, clock display blinks and the schedule does not operate.

If the clock is not set, Check code / Notice code history will not recorded with correct time.

Clock

Clock setting
1. Clock
2. Daylight-saving

Clock				
Year	Month	Day	Time	
^	^	^	^	^
2020	01	01	00	: 00
v	v	v	v	v
● Confirm		↩ Return		

1 In the **Settings Menu** screen, select **Clock** and then press **[●] (Confirm)**.

The “Clock setting” screen is displayed.

2 In the **Clock setting** screen, select **Clock** and then press **[●] (Confirm)**.

The “Clock” screen is displayed.

3 Move the cursor using **[<]** and **[>]**, change the year, month, day, and time using **[^]** and **[v]**, and then press **[●] (Confirm)**.

The “Clock setting” screen is displayed again.

• NOTE

- If the clock is not set, the clock displayed in the upper right of the All, Zone, or Unit screen blinks.
- The retention period in case of a power outage is approximately 3 days.
- If power is not supplied for a long period of time, the clock is initialized to “2020 01 01 00:00”.

Daylight-saving

Clock setting	
1. Clock	
2. Daylight-saving	

Daylight-saving	
1. Shift time	<OFF>
2. Start date	<03/29 01:00>
3. End date	<10/25 02:00>

◆ Shift time

Shift time	
ON	
● OFF	

◆ Start date / End date

Example: Start date

Start date			
	Month	Day	Time
	^	^	^
	03	29	01 : 00
	v	v	v
	• Confirm	↩ Return	

- 1 In the Settings Menu screen, select Clock and then press [●] (Confirm).**

The “Clock setting” screen is displayed.

- 2 Select Daylight-saving using [^] and [v], and then press [●] (Confirm).**

The “Daylight-saving” screen is displayed.

- 1 In the Daylight-saving screen, select Shift time and then press [●] (Confirm).**

The “Shift time” screen is displayed.

- 2 Select ON or OFF using [^] and [v], and then press [●] (Confirm).**

If “ON” is set and the time set in “Start date” is reached, the clock is advanced by 1 hour.

When the time set in “End date” is reached, the clock is restored to the original time.

- If you press [↵] (Return), the “Daylight-saving” screen is displayed again.
- During the “Daylight-saving” period, ☀ is displayed above the clock.

- 1 In the Daylight-saving screen, select Start date and then press [●] (Confirm).**

The “Start date” screen is displayed.

- 2 Move the cursor using [<] and [>], change the month, day, and time using [^] and [v], and then press [●] (Confirm).**

The “Daylight-saving” screen is displayed again.

Changing the First Day of the Week (First Day)

Set the first day of the week to be displayed in the “Weekly display”, “Weekly Schedule”, and other screens of the Operating Schedule.

Schedule settings
1. Operating Sch Enable/Void
2. Operating Sch settings
3. Energy Saving Schedule
4. First day

1 In the Settings Menu screen, select Schedule settings and then press [●] (Confirm).

The “Schedule settings” screen is displayed.

2 Select First day using [^] and [v], and then press [●] (Confirm).

The “First day” screen is displayed.

First day
● Sunday
Monday

3 Select a day of the week using [^] and [v], and then press [●] (Confirm).

The selected day of the week is set.

- If you press [↵] (Return), the “Schedule settings” screen is displayed again.
- By default, “Sunday” is set.

Example: Operating Sch settings and “Weekly display” screen

First day

ZONE-1	≡ Weekly
Sun	Mon. Tue. Wed. Thu. Fri. Sat.
AUG 9~	9 10 11 <u>12</u> 13 14 15
▼	○ ○ ○ ○ ○ ○ ○
○ Enable	× Void ◇ Special day

4 Basic Usage

4-1. Air conditioner

This section explains commonly used functions such as starting/stopping air conditioner operation, set temperature, and operation mode.

Start/Stop Operation

CAUTION Always turn off the power circuit breaker if the product malfunctions due to lightning or wireless, etc. during operation. (Cause of failure)

Start/Stop Operation of All air conditioners

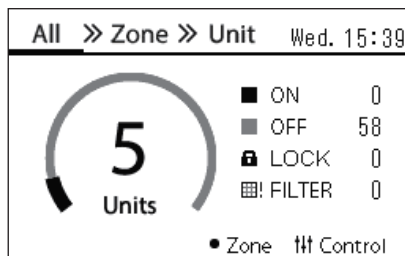
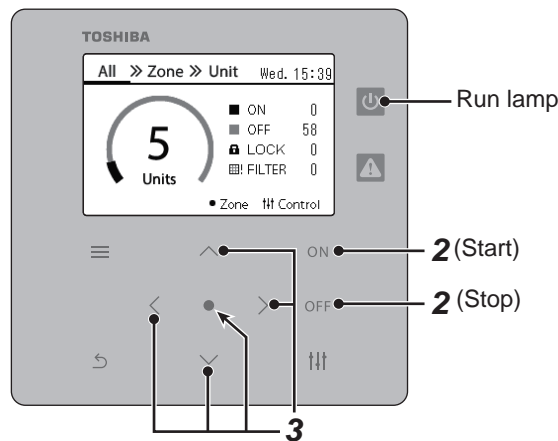

1 Display the All screen. (P.15)

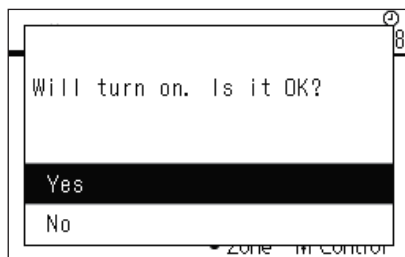

To start

2 Press [ON].

The confirmation screen is displayed.

3 Press [^] [v] to select Yes , then press [●] (Confirm).

All air conditioners start operation, and the Run lamp lights up.

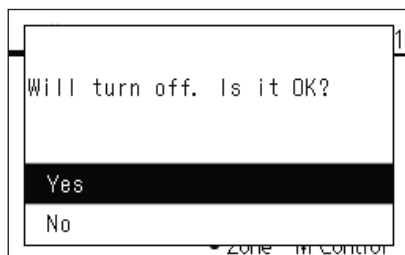

To stop

2 Press [OFF].

The confirmation screen is displayed.

3 Press [^] [v] to select Yes , then press [●] (Confirm).

All air conditioners stop operation, and the Run lamp turns off.

NOTE

- If necessary, set the temperature, operation mode (Cool/Heat, etc.), fan speed, and louver. (P.23)
- Air to Water Heat Pump is not included in the control target when operation is carried out all at once.

Start/Stop Operation of All air conditioners in a Zone

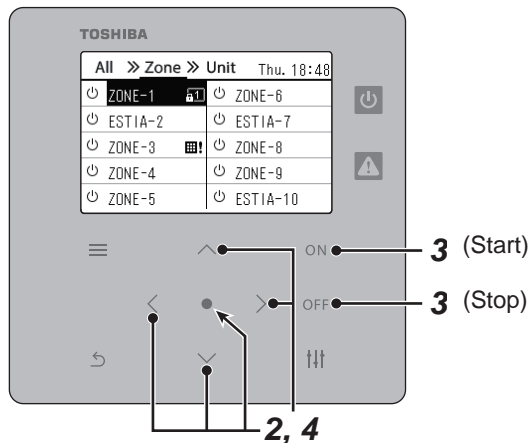

All >> Zone >> Unit Thu. 18:48	
☰ ZONE-1	☰ ZONE-6
☰ ESTIA-2	☰ ESTIA-7
☰ ZONE-3	☰ ZONE-8
☰ ZONE-4	☰ ZONE-9
☰ ZONE-5	☰ ESTIA-10

1 Display the Zone screen. (P.15)

2 Press [] [] [] [] to select a Zone.
The selected Zone is highlighted.

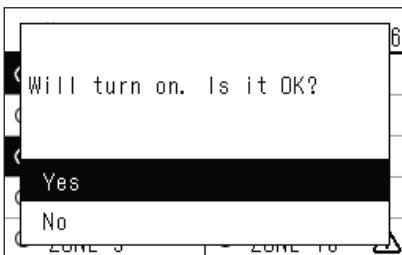

To start

3 Press [ON].

The confirmation screen is displayed.

4 Press [] [] to select Yes, then press [] (Confirm).

All air conditioners in the selected Zone start operation and changes to .

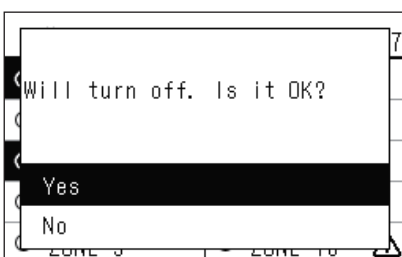

To stop

3 Press [OFF].

The confirmation screen is displayed.

4 Press [] [] to select Yes, then press [] (Confirm).

All air conditioners in the selected Zone stop operation and changes to .

NOTE

If necessary, set the temperature, operation mode (Cool/Heat, etc.), fan speed, and louver. (P.23)

Start/Stop Operation of an Individual air conditioner

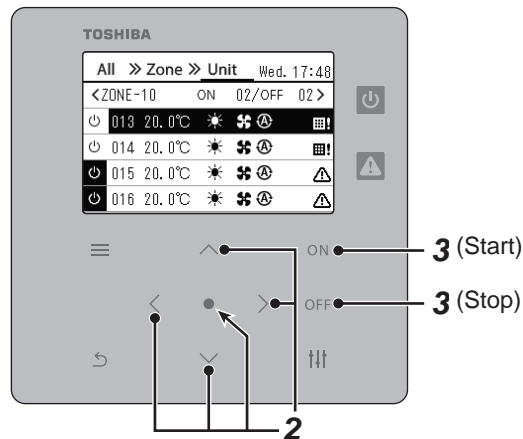

All >> Zone >> Unit		Fri. 15:02	
<ZONE-1		ON	4 /OFF 2 >
01	20.0°C	☀	🌀
02	20.0°C	☀	🌀
03	20.0°C	☀	🌀
04	20.0°C	☀	🌀

1 Display the **Unit** screen. (P.15)

2 Press [**<**] [**>**] to select a Zone then press [**^**] [**v**] to select an air conditioner.



To start

3 Press [**ON**].

The selected air conditioner starts operation and  changes to .

To stop

3 Press [**OFF**].

The selected air conditioner stops operation and  changes to .

NOTE

If necessary, set the temperature, operation mode (Cool/Heat, etc.), fan speed, and louver. (P.23)

Changing air conditioner Settings (Set Temperature, Operation Mode, Fan Speed, and Louver)

You can change the set temperature, operation mode, fan speed, and louver.
Depending on the range of the area to be set, display and operate the “Control” screen of All, Zone, or Unit.

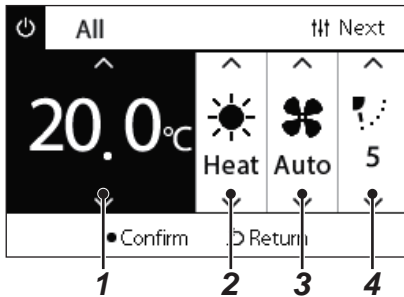

- 1** Display the **Control** screen of All, Zone, or Unit (P.15)
- 2** Use [**<**] and [**>**] to select the item to change.
For details of the setting of each item, see the table below.
- 3** Make changes using [**^**] and [**v**], and then press [**●**] (**Confirm**).
 - The changes to the settings are not reflected on the air conditioner unless you press [**●**] (**Confirm**).

No.	Item	Description																				
1	Set temperature	You can change the set temperature using [^] and [v]. NOTE <ul style="list-style-type: none"> • The set temperature cannot be changed when the operation mode is Fan. • The temperature range that can be set differs depending on the operation mode. • If a temperature outside the set temperature range of the relevant operation mode is set, the temperature is changed to the upper- or lower-limit temperature of the range. 																				
2	Operation mode	You can change the operation mode using [^] and [v]. <table border="1" style="width: 100%; text-align: center;"> <tr> <td> AUTO</td> <td> HEAT</td> <td> COOL</td> <td> FAN</td> <td> DRY</td> </tr> </table> NOTE The operation modes that cannot be set are not displayed.	AUTO	HEAT	COOL	FAN	DRY															
AUTO	HEAT	COOL	FAN	DRY																		
3	Fan speed	You can change the fan speed using [^] and [v]. <table border="1" style="width: 100%; text-align: center;"> <tr> <td>Auto</td> <td>■</td> <td>■■</td> <td>■■■</td> <td>■■■■</td> <td>■■■■■</td> </tr> </table> NOTE <ul style="list-style-type: none"> • The fan speeds that cannot be set are not displayed. • A blank is displayed if the fan speed is fixed. 	Auto	■	■■	■■■	■■■■	■■■■■														
Auto	■	■■	■■■	■■■■	■■■■■																	
4	Louver	You can change the louver to the following, using [^] and [v]. <table border="1" style="width: 100%; text-align: center;"> <tr> <td></td> <td></td> <td></td> <td></td> <td></td> <td></td> <td></td> </tr> <tr> <td>Swing</td> <td>Swing stopped</td> <td>F1</td> <td>F2</td> <td>F3</td> <td>F4</td> <td>F5</td> </tr> </table> <table border="1" style="width: 100%;"> <thead> <tr> <th style="width: 50%;">Operation Mode</th> <th style="width: 50%;">Setting range</th> </tr> </thead> <tbody> <tr> <td>Auto (Cool), Cool, Dry</td> <td>Swing → Swing stopped → F1 → F2 → F3 → Swing (back to the beginning)</td> </tr> <tr> <td>Auto (Heat), Heat, Fan</td> <td>Swing → Swing stopped → F1 → F2 → F3 → F4 → F5 → Swing (back to the beginning)</td> </tr> </tbody> </table> NOTE <ul style="list-style-type: none"> • The louver position may differ for the header and follower units. • The setting range differs depending on the operation mode. 								Swing	Swing stopped	F1	F2	F3	F4	F5	Operation Mode	Setting range	Auto (Cool), Cool, Dry	Swing → Swing stopped → F1 → F2 → F3 → Swing (back to the beginning)	Auto (Heat), Heat, Fan	Swing → Swing stopped → F1 → F2 → F3 → F4 → F5 → Swing (back to the beginning)
Swing	Swing stopped	F1	F2	F3	F4	F5																
Operation Mode	Setting range																					
Auto (Cool), Cool, Dry	Swing → Swing stopped → F1 → F2 → F3 → Swing (back to the beginning)																					
Auto (Heat), Heat, Fan	Swing → Swing stopped → F1 → F2 → F3 → F4 → F5 → Swing (back to the beginning)																					

Setting the Operating Schedule

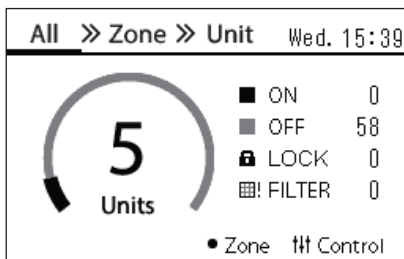

1 In the **All** screen, press [≡] (Menu).
The “Settings Menu” screen is displayed.

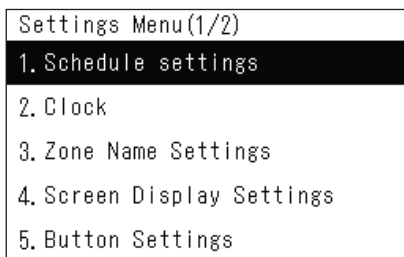

2 In the **Settings Menu** screen, select **Schedule settings** and then press [●] (Confirm).
The “Schedule settings” screen is displayed.

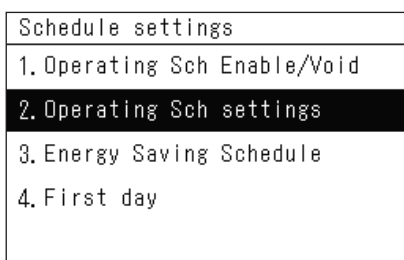

3 Select **Operating Sch settings** using [^] and [v], and then press [●] (Confirm).
The “Select Zone” screen is displayed.

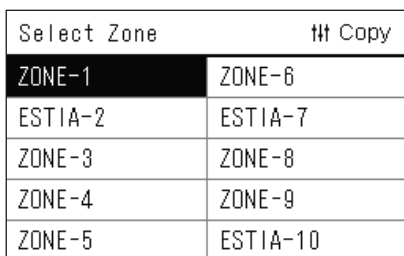

4 Select the zone to set using [<], [^], [v], and [>], and then press [●] (Confirm).
The “Weekly display” screen of the selected zone is displayed.

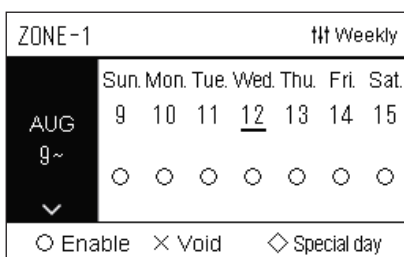

5 Press [↑↑] (Control).
The “Weekly Schedule” screen is displayed.

- In the “Weekly display” screen, you can make the Operating Schedule void or set the unit to operate according to the special day schedule.
- You can set dates for up to 5 weeks ahead.

Weekly Schedule		# Copy
Sp2	< Sun >	Mon
1	--:-- -- --.°C -- --	
2	--:-- -- --.°C -- --	
3	--:-- -- --.°C -- --	
4	--:-- -- --.°C -- --	

Select the day of week to set using [**<**] and [**>**] and the schedule to set using [**^**] and [**v**], and then press [**●**] (Confirm).

The "Schedule editing" screen is displayed.

Sunday		# Next
<u>1</u>	2 3 4 5 6 7 8	
^	^	
--	:--	-- -- - - -
●	●	
Time	Operation switching	

Move the cursor using [**<**] and [**>**], and set the time using [**^**] and [**v**].

You cannot switch the operation unless you set the time.

Sunday		# Next
<u>1</u>	2 3 4 5 6 7 8	
^	^	
08:00	ON	-- - - -
v	v	
● Confirm	↵ Return	

Place the cursor on Operation switching using [**<**] and [**>**], switch to ON or OFF using [**^**] and [**v**], and then press [**●**] (Confirm).

The "Weekly Schedule" screen is displayed again, with the set schedule added to the list.

- If you press [**↵**] (Return) without pressing [**●**] (Confirm), the setting is cancelled and the screen returns to the state it was in before the change was made.

Changing the Operating Schedule (Operating Sch Enable/Void and Operating Sch settings)

NOTE

- Set the clock before setting the schedule.
- If the Operating Schedule or Energy Saving Schedule is enabled,  is displayed above the clock.
- If no indoor unit is set for the zone, the schedule cannot be set.
- Schedule settings do not take effect in the following cases.
The clock is blinking (not set), the target zone is set to Void in “Operating Sch Enable/Void”, or Void is set in the “Weekly display” screen.
- You can set the temperature in the range of 18 to 29 °C. (If the set temperature range has been changed, you can set the temperature in that range.)

Changing the details of the Operating Schedule settings

Operating Sch Enable/Void

Schedule settings
1. Operating Sch Enable/Void
2. Operating Sch settings
3. Energy Saving Schedule
4. First day

Select Zone
ZONE-1 <○> ZONE-6 <○>
ZONE-2 <○> ZONE-7 <○>
ZONE-3 <○> ZONE-8 <○>
ZONE-4 <○> ZONE-9 <○>
ZONE-5 <○> ZONE-10 <○>

ZONE-1
●<○>Enable
<X>Void

- 1 In the Settings Menu screen, select Schedule settings and then press [●] (Confirm).**
The “Schedule settings” screen is displayed.
- 2 Select Operating Sch Enable/Void using [^] and [v], and then press [●] (Confirm).**
The “Select Zone” screen is displayed.
- 3 Select the zone to change using [<], [^], [v], and [>], and then press [●] (Confirm).**
The “Enable/Void setting” screen of the selected zone is displayed.
 - The current setting is displayed in < >.
- 4 Select Enable or Void using [^] and [v], and then press [●] (Confirm).**
The selected item is set.
 - If you press [↵] (Return), the “Select Zone” screen is displayed again.

Operating Sch settings

Schedule settings
1. Operating Sch Enable/Void
2. Operating Sch settings
3. Energy Saving Schedule
4. First day

Select Zone

Select Zone	# Copy
ZONE-1	ZONE-6
ESTIA-2	ESTIA-7
ZONE-3	ZONE-8
ZONE-4	ZONE-9
ZONE-5	ESTIA-10

Weekly display

ZONE-1	# Weekly
AUG 9~	Sun. Mon. Tue. Wed. Thu. Fri. Sat.
	9 10 11 <u>12</u> 13 14 15
	○ ○ ○ ○ ○ ○ ○
○ Enable × Void ◇ Special day	

ZONE-1	# Weekly
AUG 9~	Sun. Mon. Tue. Wed. Thu. Fri. Sat.
	9 10 11 <u>12</u> 13 14 15
	^ ^ ^ ^ ^ ^ ^
	○ ○ ○ ○ ○ ○ ○
○ Enable × Void ◇ Special day	

Weekly Schedule

Weekly Schedule	# Copy
Sp2 < Sun > Mon	
1 08:00 ON 26.0°C ☀️ 🔒1	
2 12:00 OFF --. -°C -- --	
3 13:00 ON 27.0°C ☀️ 🔒2	
4 18:00 OFF --. -°C -- 🔒	

1 In the All screen, press [≡] (Menu).

The "Settings Menu" is displayed.

2 In the Settings Menu screen, select Schedule settings and then press [●] (Confirm).

The "Schedule settings" screen is displayed.

3 Select Operating Sch settings using [^] and [v], and then press [●] (Confirm).

The "Select Zone" screen is displayed.

- The zones for which no air conditioner is registered are not displayed.

4 Select the zone to set using [<], [^], [v], and [>], and then press [●] (Confirm).

The "Weekly display" screen of the selected zone is displayed.

5 Select week to change using [^] and [v], and then press [●] (Confirm).

The cursor moves to the first day of the selected week.

Select the date using [<] and [>], change ○ (Enable), × (Void), and ◇ (Special day) using [^] and [v], and then press [●] (Confirm).

The cursor moves to the week of the "Weekly display".

- If you press [↵] (Return) without pressing [●] (Confirm), the setting is cancelled and the screen returns to the state it was in before the change was made.
- If you do not press [●] (Confirm) after making the change, you cannot switch to the "Weekly Schedule" screen.
- You can make the settings for up to 5 weeks ahead.
- By default, ○ (Enable), is set for all days.
- For information about the setting of special days, see "Changing the details of the special day schedule settings" (P.31).

Place the cursor on the Weekly display (left end) or the day of the week you want to set, and the press [↑↓] (Control).

The "Weekly Schedule" screen is displayed.

Select the day of week to set using [<] and [>] and the schedule to set using [^] and [v], and then press [●] (Confirm).

The "Schedule editing" screen is displayed.

- No more than 8 schedules can be set a day.

Schedule editing

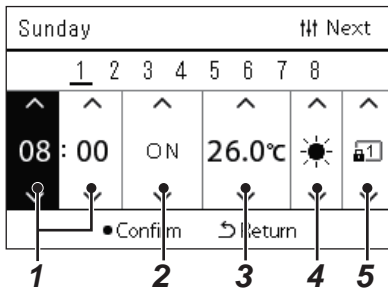

Move the cursor using [**<**] and [**>**], and set the time using [**^**] and [**v**].

- 1 Select an item using [**<**] and [**>**], change the setting using [**^**] and [**v**], and then press [**●**] (Confirm).

The “Weekly Schedule” screen is displayed again, with the set schedule added to the list.

- If you press [**↵**] (Return) without pressing [**●**] (Confirm), the setting is cancelled and the screen returns to the state it was in before the change was made.
- For details of the setting of each item, see “Setting item list”.

Setting item list

No.	Item	Description																																						
1	Time	Change the time using [^] and [v]. NOTE If the time is not set, you cannot set ON/OFF, set temperature, operation mode, or key lock.																																						
2	ON/OFF	You can change ON/OFF using [^] and [v]. NOTE If you set “--”, the last state is maintained.																																						
3	Set temperature	You can change the set temperature using [^] and [v]. NOTE If you set “--”, the last set temperature is maintained to continue the operation.																																						
4	Operation mode	You can change the operation mode to the following, using [^] and [v]. <table border="1" style="width: 100%; text-align: center;"> <tr> <td> AUTO</td> <td> HEAT</td> <td> COOL</td> <td> FAN</td> <td> DRY</td> </tr> </table> NOTE The operation modes that cannot be set are not displayed.	AUTO	HEAT	COOL	FAN	DRY																																	
AUTO	HEAT	COOL	FAN	DRY																																				
5	Key lock	You can change the key lock to the following, using [^] and [v]. <table border="1" style="width: 100%; text-align: center;"> <thead> <tr> <th rowspan="2">Icon</th> <th rowspan="2">Setting items</th> <th colspan="3">Function prohibited for remote control</th> </tr> <tr> <th>ON/OFF</th> <th>Operation Mode</th> <th>Set temperature</th> </tr> </thead> <tbody> <tr> <td>--</td> <td>—</td> <td colspan="3">The last lock state is maintained.</td> </tr> <tr> <td></td> <td>Unlock</td> <td>-</td> <td>-</td> <td>-</td> </tr> <tr> <td></td> <td>Lock 1</td> <td>○</td> <td>-</td> <td>-</td> </tr> <tr> <td></td> <td>Lock 2</td> <td>○</td> <td>○</td> <td>○</td> </tr> <tr> <td></td> <td>Lock 3</td> <td>-</td> <td>○</td> <td>○</td> </tr> <tr> <td></td> <td>Lock 4</td> <td>-</td> <td>○</td> <td>-</td> </tr> </tbody> </table> NOTE If the Local Control Mode is set, you cannot set key lock.	Icon	Setting items	Function prohibited for remote control			ON/OFF	Operation Mode	Set temperature	--	—	The last lock state is maintained.				Unlock	-	-	-		Lock 1	○	-	-		Lock 2	○	○	○		Lock 3	-	○	○		Lock 4	-	○	-
Icon	Setting items	Function prohibited for remote control																																						
		ON/OFF	Operation Mode	Set temperature																																				
--	—	The last lock state is maintained.																																						
	Unlock	-	-	-																																				
	Lock 1	○	-	-																																				
	Lock 2	○	○	○																																				
	Lock 3	-	○	○																																				
	Lock 4	-	○	-																																				

Copying the Operating Schedule

◆ Copying the Operating Schedule to another zone

Select Zone	↑↑ Copy
ZONE-1	ZONE-6
ESTIA-2	ESTIA-7
ZONE-3	ZONE-8
ZONE-4	ZONE-9
ZONE-5	ESTIA-10

Sel Copy Destination	
	ZONE-6
ZONE-3	ZONE-8
ZONE-4	ZONE-9
ZONE-5	

Sel Copy Destination	↑ Start
	ZONE-6
● ZONE-3	ZONE-8
ZONE-4	ZONE-9
ZONE-5	

1 Display the Select Zone screen (Steps 1 to 3 of Operating Sch settings (P.27)).

2 Select the copy source zone using [<], [∧], [∨], and [>], and then press [↑↑] (Control).

The "Sel Copy Destination" screen is displayed.

3 Select the copy destination zone using [<], [∧], [∨], and [>], and then press [●] (Confirm).

For the selected copy destination, "●" is displayed to the left of the zone name.

If you press [●] (Confirm) in the zone in which "●" is displayed, the selection is cancelled.

- If there is only one zone for which an air conditioner is registered, you cannot perform the copy operation.
- Only the zones for which an air conditioner is registered are displayed.
- The copy source zone is not displayed.
- Multiple copy destinations can be selected.
- You cannot copy the schedule set in an ESTIA zone to an air conditioner zone.

4 After selecting the copy destination, press [↑↑] (Control).

"Copy Complete" is displayed, and the "Select Zone" screen is displayed again.

◆ Copying the Operating Schedule to another day of the week

Weekly Schedule	↑↑ Copy
Sp2 < Sun > Mon	
1 08:00 ON 26.0°C ⚙️ 🔒1	
2 12:00 OFF --. -°C -- --	
3 13:00 ON 27.0°C ⚙️ 🔒2	
4 18:00 OFF --. -°C -- 🔒	

Sel Copy Destination	
Mon. Tue. Wed. Thu. Fri. Sat.	
• Select/Cancel	

1 Display the Weekly Schedule screen (Steps 1 to 7 of Operating Sch settings (P.27)).

2 Select the copy source day using [<] and [>], and then press [↑↑] (Control).

The "Sel Copy Destination" screen is displayed.

3 Select the copy destination day using [<] and [>], and then press [●] (Confirm).

For the selected copy destination day, "●" is displayed below it.

- The copy source day is not displayed.
- Multiple copy destinations can be selected.
- The schedule cannot be copied to a special day.

Sel Copy Destination	†† Start
Mon. Tue. Wed. Thu. Fri. Sat.	
●	
● Select/Cancel	

- 4** After selecting the copy destination, press [††] (Control).
 “Copy Complete” is displayed, and the “Weekly Schedule” screen is displayed again.

Deleting the Operating Schedule

Weekly Schedule	†† Del
Sp2 < Sun > Mon	
1 08:00 ON 26.0°C ⚙️ 🔒1	
2 12:00 OFF --.-°C -- --	
3 13:00 ON 27.0°C ⚙️ 🔒2	
4 18:00 OFF --.-°C -- 🔒	

Delete schedule?
Is it OK?
Yes
No

Weekly Schedule	†† Del
Sp2 < Sun > Mon	
1 12:00 OFF --.-°C -- --	
2 13:00 ON 27.0°C ⚙️ 🔒2	
3 18:00 OFF --.-°C -- 🔒	
4 --:-- -- --.-°C -- --	

- 1** Display the **Weekly Schedule** screen (Steps 1 to 7 of Operating Sch settings (P.27)).
- 2** Place the cursor on the schedule you want to delete in the **Weekly Schedule** screen, and the press [††] (Control).
 The “Delete schedule” confirmation screen is displayed.
 • You cannot delete a schedule if no schedule is set.
- 3** Select **Yes** using [^] and [v], and then press [●] (Confirm).
 The selected schedule is deleted, and the “Weekly Schedule” screen is displayed again.
 If you select “No”, and the “Weekly Schedule” screen is displayed again without deleting the schedule.

Changing the details of the special day schedule settings

On a day set as a special day in the “Weekly display” screen, the operation occurs according to the schedule set in “Sp1” or “Sp2”, not the schedule set for the day of the week.

Weekly display

ZONE-1		t# Weekly					
	Sun.	Mon.	Tue.	Wed.	Thu.	Fri.	Sat.
AUG	9	10	11	12	13	14	15
g~	^	^	^	^	^	^	^
	○	○	○	○	◇	○	○
	v	v	v	v	v	v	v
○ Enable		× Void		◇ Special day			

Weekly Schedule

Weekly Schedule							
Sat	<	Sp1	>	Sp2			
1	--:--	--	--	-.°C	--	--	
2	--:--	--	--	-.°C	--	--	
3	--:--	--	--	-.°C	--	--	
4	--:--	--	--	-.°C	--	--	

Schedule editing

Sp1		t# Next						
	1	2	3	4	5	6	7	8
^	^							
--	:	--	--	---	--	--		
v	v							

Sp1		t# Next						
	1	2	3	4	5	6	7	8
^	^	^	^	^	^	^	^	^
10	:	00	ON	27.0°C	☀	--		
v	v	v	v	v	v	v	v	v

- 1** Display the Weekly display screen (Steps 1 to 6 of Operating Sch settings (P.27)).
- 2** Place the cursor on the week of the Weekly display or the day set as a special day, and the press [t#t#] (Control).
The “Weekly Schedule” screen is displayed.
- 3** Select Sp1 or Sp2 using [<] and [>] and the schedule to set using [^] and [v], and then press [●] (Confirm).
The “Schedule editing” screen is displayed.
 - No more than 8 schedules can be set a day.
 - Sp1 : Special day 1
 - Sp2 : Special day 2
- 4** Move the cursor using [<] and [>], and set the time using [^] and [v].
 - If the time is not set, you cannot set ON/OFF, temperature, or key lock.
- 5** Select an item using [<] and [>], change the setting using [^] and [v], and then press [●] (Confirm).
The “Weekly Schedule” screen is displayed again, with the set schedule added to the list.

Changing the Energy Saving Schedule (Energy Saving Schedule)

Changing the details of the Energy Saving Schedule settings

Schedule settings
1. Operating Sch Enable/Void
2. Operating Sch settings
3. Energy Saving Schedule
4. First day

1 In the **Settings Menu** screen, select **Schedule settings** and then press **[●]** (**Confirm**).

The “Schedule settings” screen is displayed.

2 Select **Energy Saving Schedule** using **[^]** and **[v]**, and then press **[●]** (**Confirm**).

The “Select Zone” screen is displayed.

- The zones for which no air conditioner is registered are not displayed.

Select Zone	# Copy
ZONE-1	ZONE-6
ESTIA-2	ESTIA-7
ZONE-3	ZONE-8
ZONE-4	ZONE-9
ZONE-5	ESTIA-10

3 Select the zone to set using **[<]**, **[^]**, **[v]**, and **[>]**, and then press **[●]** (**Confirm**).

The “Weekly Schedule” screen is displayed.

- You cannot set an Energy-saving Schedule for a zone where Air to Water Heat Pump is set.

Weekly Schedule	# Copy
Sat < Sun > Mon	
1 --:-- Release	
2 --:-- Release	
3 --:-- Release	
4 --:-- Release	

4 Select the day of week to set using **[<]** and **[>]** and the schedule to set using **[^]** and **[v]**, and then press **[●]** (**Confirm**).

The “Schedule editing” screen is displayed.

- No more than 8 schedules can be set a day.

Sunday	# Next
<u>1</u> 2 3 4 5 6 7 8	
^ ^	
-- : --	Release
v v	

5 Move the cursor using **[<]** and **[>]**, and set the time using **[^]** and **[v]**.

- If the time is not set, you cannot set the save rate.

Sunday	# Next
<u>1</u> 2 3 4 5 6 7 8	
^ ^	
08 : 00	Release
v v	
• Confirm ↵ Return	

Change the save rate using [^] and [v], and then press [●] (Confirm).

The “Weekly Schedule” screen is displayed again, with the set schedule added to the list.

• NOTE

The operation continues at the last set save rate unless you change to “Release” in “Energy saving operation” or “Energy Saving Schedule”.

Copying the Energy Saving Schedule

◆ Copying the Energy Saving Schedule to another zone

Select Zone	↑↑ Copy
ZONE-1	ZONE-6
ZONE-2	ZONE-7
ZONE-3	ZONE-8
ZONE-4	ZONE-9
ZONE-5	ZONE-10

Sel Copy Destination	
	ZONE-6
ZONE-2	ZONE-7
ZONE-3	ZONE-8
ZONE-4	ZONE-9
ZONE-5	ZONE-10

Sel Copy Destination	● Start
	ZONE-6
● ZONE-2	ZONE-7
ZONE-3	ZONE-8
ZONE-4	ZONE-9
ZONE-5	ZONE-10

1 Display the **Select Zone** screen (Steps 1 and 2 of **Changing the details of the Energy Saving Schedule settings (P.32)**).

2 Select the copy source zone using [**<**], [**^**], [**v**], and [**>**], and then press [**↑↑**] (**Control**).

The “Sel Copy Destination” screen is displayed.

3 Select the copy destination zone using [**<**], [**^**], [**v**], and [**>**], and then press [**●**] (**Confirm**).

For the selected copy destination, “●” is displayed to the left of the zone name.

If you press [**●**] (**Confirm**) in the zone in which “●” is displayed, the selection is cancelled.

- If there is only one zone for which an air conditioner is registered, you cannot perform the copy operation.
- Only the zones for which an air conditioner is registered are displayed.
- The copy source zone is not displayed.
- Multiple copy destinations can be selected.

4 After selecting the copy destination, press [**↑↑**] (**Control**).

“Copy Complete” is displayed, and the “Select Zone” screen is displayed again.

◆ Copying the Energy Saving Schedule to another day of the week

Weekly Schedule	↑↑ Copy
Sat < Sun > Mon	
1 08:00 50%	
2 10:00 Maximum	
3 12:00 0%	
4 22:00 Release	

Sel Copy Destination	
Mon	Tue. Wed. Thu. Fri. Sat.
● Select/Cancel	

1 Display the **Weekly Schedule** screen (Steps 1 to 3 of **Changing the details of the Energy Saving Schedule settings (P.32)**).

2 Select the copy source day using [**<**] and [**>**], and then press [**↑↑**] (**Control**).

The “Sel Copy Destination” screen is displayed.

3 Select the copy destination day using [**<**] and [**>**], and then press [**●**] (**Confirm**).

For the selected copy destination day, “●” is displayed below it.

- The copy source day is not displayed.
- Multiple copy destinations can be selected.

Sel Copy Destination	†† Start
Mon. Tue. Wed. Thu. Fri. Sat.	
●	
● Select/Cancel	

- 4** After selecting the copy destination, press [††] (Control).
 “Copy Complete” is displayed, and the “Weekly Schedule” screen is displayed again.

Deleting the Energy Saving Schedule

Weekly Schedule	†† Del
Sat < Sun > Mon	
1 08:00 50%	
2 10:00 Maximum	
3 12:00 0%	
4 22:00 Release	

- 1** Display the **Weekly Schedule** screen (Steps 1 to 3 of **Changing the details of the Energy Saving Schedule settings (P.32)**).

- 2** Place the cursor on the schedule you want to delete in the **Weekly Schedule** screen, and the press [††] (Control).

The “Delete schedule” confirmation screen is displayed.

- You cannot delete a schedule if no schedule is set.

Delete schedule?
Is it OK?
Yes
No

- 3** Select **Yes** using [^] and [v], and then press [●] (Confirm).

The selected schedule is deleted, and the “Weekly Schedule” screen is displayed again.

If you select “No”, and the “Weekly Schedule” screen is displayed again without deleting the schedule.

Weekly Schedule	†† Del
Sat < Sun > Mon	
1 10:00 Maximum	
2 12:00 0%	
3 22:00 Release	
4 --:-- Release	

4-2. Air to Water Heat Pump

This section explains commonly used functions such as starting/stopping air conditioner operation, set temperature, and operation mode.

Start/Stop Operation

CAUTION Always turn off the power circuit breaker if the product malfunctions due to lightning or wireless, etc. during operation. (Cause of failure)

Start/Stop Operation of All Air to Water Heat Pumps

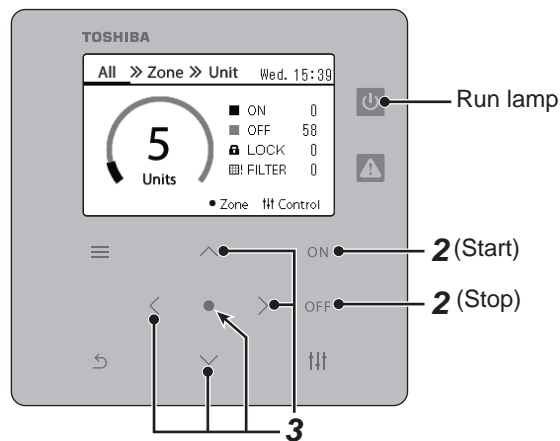

1 Display the All screen. (P.16)

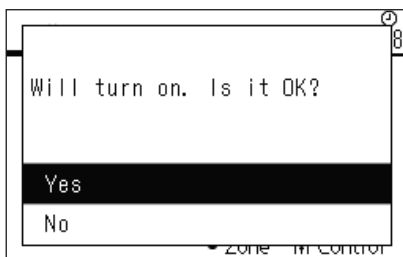
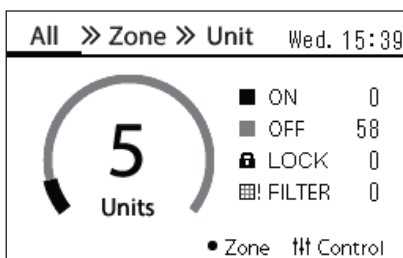

To start

- 2** Press [ON].
The confirmation screen is displayed.
- 3** Press [^] [v] to select **Yes** , then press [●] (Confirm).
All Air to Water Heat Pump start operation, and the Run lamp lights up.

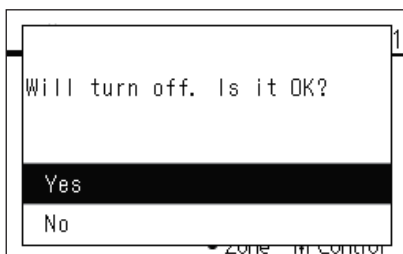

To stop

- 2** Press [OFF].
The confirmation screen is displayed.
- 3** Press [^] [v] to select **Yes** , then press [●] (Confirm).
All Air to Water Heat Pump stop operation, and the Run lamp turns off.

NOTE

If necessary, set the temperature, operation mode (Cool/Heat). (P.38)

Start/Stop Operation of All Air to Water Heat Pump in a Zone

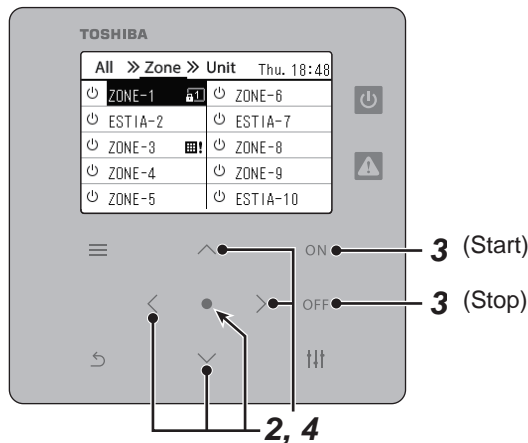

All >> Zone >> Unit Thu. 18:48	
☰ ZONE-1	☰ ZONE-6
☰ ESTIA-2	☰ ESTIA-7
☰ ZONE-3	☰ ZONE-8
☰ ZONE-4	☰ ZONE-9
☰ ZONE-5	☰ ESTIA-10

1 Display the Zone screen. (P.16)

2 Press [] [] [] [] to select a Zone.
The selected Zone is highlighted.

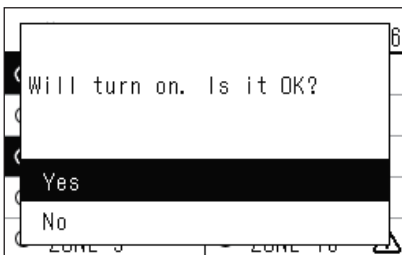

To start

3 Press [ON].

The confirmation screen is displayed.

4 Press [] [] to select Yes , then press [] (Confirm).

All Air to Water Heat Pump in the selected Zone start operation and changes to .

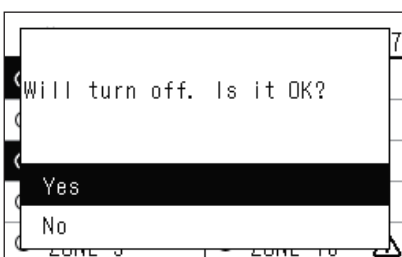

To stop

3 Press [OFF].

The confirmation screen is displayed.

4 Press [] [] to select Yes , then press [] (Confirm).

All Air to Water Heat Pump in the selected Zone stop operation and changes to .

NOTE

If necessary, set the temperature, operation mode (Cool/Heat). (P.38)

Start/Stop Operation of an Individual Air to Water Heat Pump

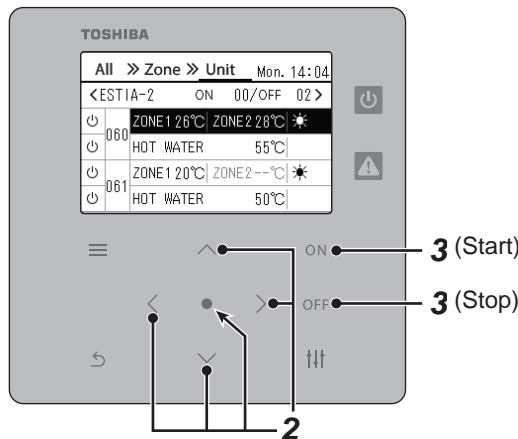



All >> Zone >> Unit		Mon. 14:04
<ESTIA-2 ON 00/OFF 02>		
☰	060	ZONE1 26°C ZONE2 28°C ☀
☰		HOT WATER 55°C
☰	061	ZONE1 20°C ZONE2 --°C ☀
☰		HOT WATER 50°C

1 Display the Unit screen. (P.16)

2 Press [←] [→] to select a Zone then press [▲] [▼] to select an Air to Water Heat Pump.



To start

3 Press [ON].

The selected Air to Water Heat Pump starts operation and  changes to .

To stop

3 Press [OFF].

The selected Air to Water Heat Pump stops operation and  changes to .

NOTE

If necessary, set the temperature, operation mode (Cool/Heat). (P.38)

Changing Air to Water Heat Pump Settings (Set Temperature, Operation Mode)

You can change the set temperature, operation mode.

Depending on the range of the area to be set, display and operate the “Control” screen of All, Zone, or Unit.

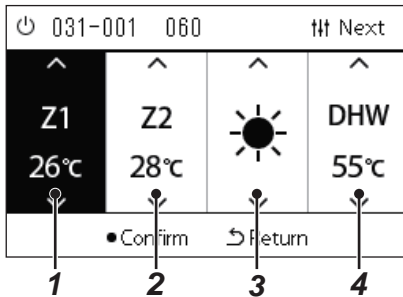



1 Display the **Control** screen of **All, Zone, or Unit (P.16)**

2 Use [**<**] and [**>**] to select the item to change.

For details of the setting of each item, see the table below.

3 Make changes using [**^**] and [**v**], and then press [**●**] (**Confirm**).

- The changes to the settings are not reflected on the Air to Water Heat Pump unless you press [**●**] (**Confirm**).

No.	Item	Description
1	ZONE1 (Z1)	You can change the set temperature using [^] and [v]. NOTE If there is no ZONE1, this will be blank.
2	ZONE2 (Z2)	You can change the set temperature using [^] and [v]. NOTE If there is no ZONE2, this will be blank.
3	Operation mode	You can change the operation mode to the following, using [^] and [v]. <div style="display: flex; justify-content: center; gap: 20px;"> <div style="text-align: center;">  HEAT </div> <div style="text-align: center;">  COOL </div> </div> NOTE The operation modes that cannot be set are not displayed.
4	Domestic Hot Water (DHW)	You can change the set temperature using [^] and [v]. NOTE If there is no Domestic Hot Water, this will be blank.

Setting the Operating Schedule

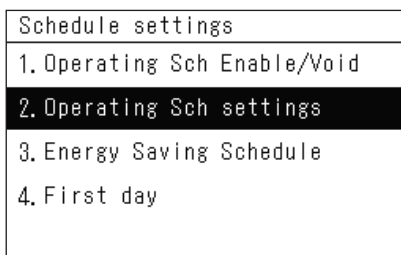
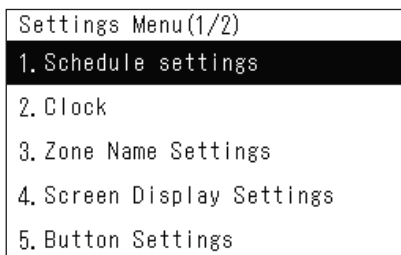
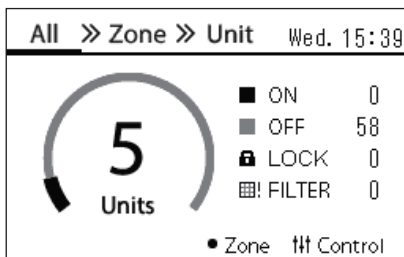

Select Zone		⏸ Copy
ZONE-1	ZONE-6	
ESTIA-2	ESTIA-7	
ZONE-3	ZONE-8	
ZONE-4	ZONE-9	
ZONE-5	ESTIA-10	

ESTIA-2		⏸ Weekly
	Sun. Mon. Tue. Wed. Thu. Fri. Sat.	
JUN 13~	13 14 15 16 17 18 19	
▼	○ ○ ○ ○ ○ ○ ○	
	○ Enable × Void ◇ Special day	

1 In the All screen, press [≡] (Menu).

The "Settings Menu" screen is displayed.

2 In the Settings Menu screen, select Schedule settings and then press [●] (Confirm).

The "Schedule settings" screen is displayed.

3 Select Operating Sch settings using [^] and [v], and then press [●] (Confirm).

The "Select Zone" screen is displayed.

4 Select the zone to set using [<], [^], [v], and [>], and then press [●] (Confirm).

The "Weekly display" screen of the selected zone is displayed.

5 Press [⏸] (Control).

The "Weekly Schedule" screen is displayed.

- In the "Weekly display" screen, you can make the Operating Schedule void or set the unit to operate according to the special day schedule.
- You can set dates for up to 5 weeks ahead.

Weekly Schedule		†† Copy	
Sp2	<	Sun	> Mon
1	--	--:--	-- -- °C -- --
2	--	--:--	-- -- °C -- --
3	--	--:--	-- -- °C -- --
4	--	--:--	-- -- °C -- --

Select the day of week to set using [**<**] and [**>**] and the schedule to set using [**^**] and [**v**], and then press [**●**] (Confirm).

The “Schedule editing” screen is displayed.

Sunday		†† Next	
<u>1</u>	2	3	4 5 6 7 8
^	^		
Z1	--	--:--	-- -- °C - -
v			

Move the cursor using [**<**] and [**>**], and set the time using [**^**] and [**v**].

You cannot switch the operation unless you set the time.

Time
Operation switching

Sunday		†† Next	
<u>1</u>	2	3	4 5 6 7 8
^	^	^	^ ^
Z1	08:00	ON	-- °C - -
v	v	v	v v
● Confirm		↵ Return	

Place the cursor on Operation switching using [**<**] and [**>**], switch to ON or OFF using [**^**] and [**v**], and then press [**●**] (Confirm).

The “Weekly Schedule” screen is displayed again, with the set schedule added to the list.

- If you press [**↵**] (Return) without pressing [**●**] (Confirm), the setting is cancelled and the screen returns to the state it was in before the change was made.

Changing the Operating Schedule (Operating Sch Enable/Void and Operating Sch settings)

NOTE

- Set the clock before setting the schedule.
- If the Operating Schedule or Energy Saving Schedule is enabled,  is displayed above the clock.
- If no indoor unit is set for the zone, the schedule cannot be set.
- Schedule settings do not take effect in the following cases.
The clock is blinking (not set), the target zone is set to Void in “Operating Sch Enable/Void”, or Void is set in the “Weekly display” screen.

Changing the details of the Operating Schedule settings

Operating Sch Enable/Void

Schedule settings
1. Operating Sch Enable/Void
2. Operating Sch settings
3. Energy Saving Schedule
4. First day

Select Zone
ZONE-1 <O> ZONE-6 <O>
ESTIA-2 <O> ESTIA-7 <O>
ZONE-3 <O> ZONE-8 <O>
ZONE-4 <O> ZONE-9 <O>
ZONE-5 <O> ESTIA-10 <O>

ESTIA-2
●<O>Enable
<X>Void

- 1 In the Settings Menu screen, select Schedule settings and then press [●] (Confirm).**
The “Schedule settings” screen is displayed.
- 2 Select Operating Sch Enable/Void using [^] and [v], and then press [●] (Confirm).**
The “Select Zone” screen is displayed.
- 3 Select the zone to change using [<], [^], [v], and [>], and then press [●] (Confirm).**
The “Enable/Void setting” screen of the selected zone is displayed.
 - The current setting is displayed in < >.
- 4 Select Enable or Void using [^] and [v], and then press [●] (Confirm).**
The selected item is set.
 - If you press [↵] (Return), the “Select Zone” screen is displayed again.

Operating Sch settings

Schedule settings
1. Operating Sch Enable/Void
2. Operating Sch settings
3. Energy Saving Schedule
4. First day

Select Zone

Select Zone	# Copy
ZONE-1	ZONE-6
ESTIA-2	ESTIA-7
ZONE-3	ZONE-8
ZONE-4	ZONE-9
ZONE-5	ESTIA-10

Weekly display

ESTIA-2	# Weekly
JUN 13~	Sun. Mon. Tue. Wed. Thu. Fri. Sat. 13 14 <u>15</u> 16 17 18 19
○	○ ○ ○ ○ ○ ○ ○
○ Enable × Void ◇ Special day	

ESTIA-2	# Weekly
JUN 13~	Sun. Mon. Tue. Wed. Thu. Fri. Sat. 13 14 <u>15</u> 16 17 18 19
○	^ ^ ^ ^ ^ ^ ^
○ Enable × Void ◇ Special day	

Weekly Schedule

Weekly Schedule	# Copy
Sp2 < Sun > Mon	
1 DHW 05:00 OFF --°C 555 --	
2 Z1 08:00 ON 25°C 555 555	
3 Z1 22:00 OFF --°C -- --	
4 DHW 23:00 ON 65°C 555 --	

1 In the All screen, press [≡] (Menu).

The "Settings Menu" is displayed.

2 In the Settings Menu screen, select Schedule settings and then press [●] (Confirm).

The "Schedule settings" screen is displayed.

3 Select Operating Sch settings using [^] and [v], and then press [●] (Confirm).

The "Select Zone" screen is displayed.

- The zones for which no air conditioner is registered are not displayed.

4 Select the zone to set using [<], [^], [v], and [>], and then press [●] (Confirm).

The "Weekly display" screen of the selected zone is displayed.

5 Select week to change using [^] and [v], and then press [●] (Confirm).

The cursor moves to the first day of the selected week.

Select the date using [<] and [>], change ○ (Enable), × (Void), and ◇ (Special day) using [^] and [v], and then press [●] (Confirm).

The cursor moves to the week of the "Weekly display".

- If you press [↵] (Return) without pressing [●] (Confirm), the setting is cancelled and the screen returns to the state it was in before the change was made.
- If you do not press [●] (Confirm) after making the change, you cannot switch to the "Weekly Schedule" screen.
- You can make the settings for up to 5 weeks ahead.
- By default, ○ (Enable), is set for all days.
- For information about the setting of special days, see "Changing the details of the special day schedule settings" (P.46).

Place the cursor on the Weekly display (left end) or the day of the week you want to set, and the press [↑↓] (Control).

The "Weekly Schedule" screen is displayed.

Select the day of week to set using [<] and [>] and the schedule to set using [^] and [v], and then press [●] (Confirm).

The "Schedule editing" screen is displayed.

- No more than 8 schedules can be set a day.

Schedule editing

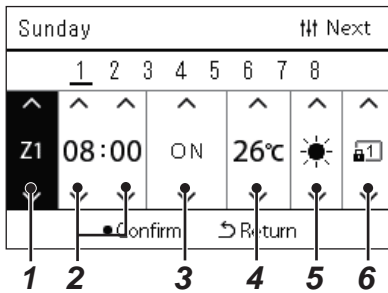

















Move the cursor using [**<**] and [**>**], and set the time using [**^**] and [**v**].

- 1 Select an item using [**<**] and [**>**], change the setting using [**^**] and [**v**], and then press [**●**] (Confirm).

The "Weekly Schedule" screen is displayed again, with the set schedule added to the list.

- If you press [**↵**] (Return) without pressing [**●**] (Confirm), the setting is cancelled and the screen returns to the state it was in before the change was made.
- For details of the setting of each item, see "Setting item list".

Setting item list

No.	Item	Description																																						
1	Setting target	Change the control target using [^] and [v].																																						
2	Time	Change the time using [^] and [v]. NOTE If the time is not set, you cannot set ON/OFF, set temperature, operation mode, or key lock.																																						
3	ON/OFF	You can change ON/OFF using [^] and [v]. NOTE If you set "--", the last state is maintained.																																						
4	Set temperature	You can change the set temperature using [^] and [v]. NOTE If you set "--", the last set temperature is maintained to continue the operation.																																						
5	Operation mode	You can change the operation mode to the following, using [^] and [v]. <div style="display: flex; justify-content: space-around; align-items: center;"> <div style="text-align: center;">  HEAT </div> <div style="text-align: center;">  COOL </div> </div> NOTE The operation modes that cannot be set are not displayed.																																						
	Key lock	You can change the key lock to the following, using [^] and [v]. <table border="1" style="margin: 10px auto;"> <thead> <tr> <th rowspan="2">Icon</th> <th rowspan="2">Setting items</th> <th colspan="3">Function prohibited for remote control</th> </tr> <tr> <th>ON/OFF</th> <th>Operation Mode</th> <th>Set temperature</th> </tr> </thead> <tbody> <tr> <td>--</td> <td>—</td> <td colspan="3">The last lock state is maintained.</td> </tr> <tr> <td></td> <td>Unlock</td> <td>-</td> <td>-</td> <td>-</td> </tr> <tr> <td></td> <td>Lock 1</td> <td>○</td> <td>-</td> <td>-</td> </tr> <tr> <td></td> <td>Lock 2</td> <td>○</td> <td>○</td> <td>○</td> </tr> <tr> <td></td> <td>Lock 3</td> <td>-</td> <td>○</td> <td>○</td> </tr> <tr> <td></td> <td>Lock 4</td> <td>-</td> <td>○</td> <td>-</td> </tr> </tbody> </table> NOTE If the Local Control Mode is set, you cannot set key lock.	Icon	Setting items	Function prohibited for remote control			ON/OFF	Operation Mode	Set temperature	--	—	The last lock state is maintained.				Unlock	-	-	-		Lock 1	○	-	-		Lock 2	○	○	○		Lock 3	-	○	○		Lock 4	-	○	-
Icon	Setting items	Function prohibited for remote control																																						
		ON/OFF	Operation Mode	Set temperature																																				
--	—	The last lock state is maintained.																																						
	Unlock	-	-	-																																				
	Lock 1	○	-	-																																				
	Lock 2	○	○	○																																				
	Lock 3	-	○	○																																				
	Lock 4	-	○	-																																				

Copying the Operating Schedule

◆ Copying the Operating Schedule to another zone

Select Zone	↑↑ Copy
ZONE-1	ZONE-6
ESTIA-2	ESTIA-7
ZONE-3	ZONE-8
ZONE-4	ZONE-9
ZONE-5	ESTIA-10

Sel Copy Destination	
	ESTIA-7
	ESTIA-10

Sel Copy Destination	● Start
	● ESTIA-7
	ESTIA-10

1 Display the **Select Zone** screen (Steps 1 to 3 of **Operating Sch settings (P.42)**).

2 Select the copy source zone using [**<**], [**^**], [**v**], and [**>**], and then press [**↑↑**] (**Control**).

The “Sel Copy Destination” screen is displayed.

3 Select the copy destination zone using [**<**], [**^**], [**v**], and [**>**], and then press [**●**] (**Confirm**).

For the selected copy destination, “●” is displayed to the left of the zone name.

If you press [**●**] (**Confirm**) in the zone in which “●” is displayed, the selection is cancelled.

- If there is only one zone for which an air conditioner is registered, you cannot perform the copy operation.
- Only the zones for which an air conditioner is registered are displayed.
- The copy source zone is not displayed.
- Multiple copy destinations can be selected.
- You cannot copy the schedule set in an air conditioner zone to an ESTIA zone.

4 After selecting the copy destination, press [**↑↑↑**] (**Control**).

“Copy Complete” is displayed, and the “Select Zone” screen is displayed again.

◆ Copying the Operating Schedule to another day of the week

Weekly Schedule	↑↑ Copy
Sp2 < Sun > Mon	
1 DHW 05:00 OFF --°C ☁ --	
2 Z1 08:00 ON 25°C ☀ 🔒	
3 Z1 22:00 OFF --°C -- --	
4 DHW 23:00 ON 65°C ☁ --	

Sel Copy Destination	
	Mon. Tue. Wed. Thu. Fri. Sat.
	● Select/Cancel

1 Display the **Weekly Schedule** screen (Steps 1 to 7 of **Operating Sch settings (P.42)**).

2 Select the copy source day using [**<**] and [**>**], and then press [**↑↑**] (**Control**).

The “Sel Copy Destination” screen is displayed.

3 Select the copy destination day using [**<**] and [**>**], and then press [**●**] (**Confirm**).

For the selected copy destination day, “●” is displayed below it.

- The copy source day is not displayed.
- Multiple copy destinations can be selected.
- The schedule cannot be copied to a special day.

Sel Copy Destination	†† Start
Mon. Tue. Wed. Thu. Fri. Sat.	
●	
● Select/Cancel	

- 4** After selecting the copy destination, press [††] (Control).
 “Copy Complete” is displayed, and the “Weekly Schedule” screen is displayed again.

Deleting the Operating Schedule

Weekly Schedule	†† Del
Sp2 < Sun > Mon	
1 DHW 05:00 OFF --°C --	
2 Z1 08:00 ON 25°C	
3 Z1 22:00 OFF --°C -- --	
4 DHW 23:00 ON 65°C --	

- 1** Display the **Weekly Schedule** screen (Steps 1 to 7 of Operating Sch settings (P.42)).

- 2** Place the cursor on the schedule you want to delete in the **Weekly Schedule** screen, and the press [††] (Control).

The “Delete schedule” confirmation screen is displayed.
 • You cannot delete a schedule if no schedule is set.

Delete schedule?
Is it OK?
Yes
No

- 3** Select **Yes** using [^] and [v], and then press [●] (Confirm).

The selected schedule is deleted, and the “Weekly Schedule” screen is displayed again.
 If you select “No”, and the “Weekly Schedule” screen is displayed again without deleting the schedule.

Weekly Schedule	†† Del
Sp2 < Sun > Mon	
1 Z1 08:00 ON 25°C	
2 Z1 22:00 OFF --°C -- --	
3 DHW 23:00 ON 65°C --	
4 -- --:-- -- --°C -- --	

Changing the details of the special day schedule settings

On a day set as a special day in the “Weekly display” screen, the operation occurs according to the schedule set in “Sp1” or “Sp2”, not the schedule set for the day of the week.

Weekly display

ESTIA-2		t t Weekly						
JUN 13~	Sun.	Mon.	Tue.	Wed.	Thu.	Fri.	Sat.	
	13	14	15	16	17	18	19	
	^	^	^	^	^	◇	^	
	○	○	○	○	○	○	○	
	∨	∨	∨	∨	∨	∨	∨	
○ Enable		× Void		◇ Special day				

Weekly Schedule

Weekly Schedule							
Sat	<	Sp1	>	Sp2			
1	--	--:--	--	--°C	--	--	
2	--	--:--	--	--°C	--	--	
3	--	--:--	--	--°C	--	--	
4	--	--:--	--	--°C	--	--	

Schedule editing

Sp1		t t Next						
	1	2	3	4	5	6	7	8
^	^	^						
Z1	--	--:--	--	--°C	--	--		
∨	∨	∨						

Sp1		t t Next						
	1	2	3	4	5	6	7	8
^	^	^	^	^	^	^	^	^
Z1	11:00	ON	28°C	☀	🔒			
∨	∨	∨	∨	∨	∨	∨	∨	∨
● Confirm		↩ Return						

- 1** Display the Weekly display screen (Steps 1 to 6 of Operating Sch settings (P.42)).
- 2** Place the cursor on the week of the Weekly display or the day set as a special day, and the press [t|t] (Control).
The “Weekly Schedule” screen is displayed.
- 3** Select Sp1 or Sp2 using [<] and [>] and the schedule to set using [^] and [∨], and then press [●] (Confirm).
The “Schedule editing” screen is displayed.
 - No more than 8 schedules can be set a day.
 - Sp1 : Special day 1
 - Sp2 : Special day 2
- 4** Move the cursor using [<] and [>], and set the time using [^] and [∨].
 - If the time is not set, you cannot set ON/OFF, temperature, or key lock.
- 5** Select an item using [<] and [>], change the setting using [^] and [∨], and then press [●] (Confirm).
The “Weekly Schedule” screen is displayed again, with the set schedule added to the list.

5 Various Functions

5-1. Air conditioner

Setting the Operation Details

You can check the current settings of the air conditioner or ON/OFF device and set the details of the operation method.

◆ Displaying the Menu screen

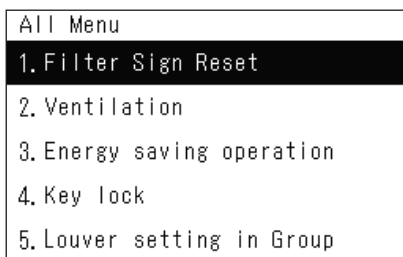
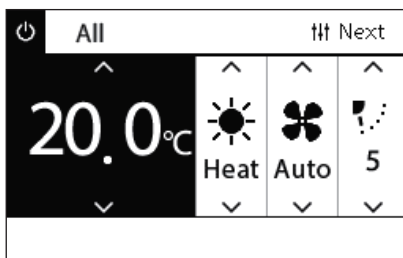

1 Display the **Control** screen of **All, Zone, or Unit** (P.15).

2 Press [**↑↑↑**] (**Control**).
The "Menu" screen is displayed.

3 Select an item using [**↑**] and [**↓**], and then press [**●**] (**Confirm**).

For the checks and settings of the individual items, see below.
The displayed items differ depending on the control range.

◆ Menu items

Setting items	Description	Page to see
Filter Sign Reset*	Used to cancel the Filter Sign.	P.48
Ventilation	Used to control the Air to air heat exchanger (ventilation-only indoor unit) linked with the air conditioner. This menu item is available when only the Air to air heat exchanger is used.	P.49
Energy saving operation	Used for energy-saving operation that limits the output of the air conditioner. Not displayed on the Unit "Menu" screen.	P.51
Key lock	Used to restrict the local remote control operation.	P.52
Louver setting in Group*	Used to disable Louver setting in Group.	P.53

* You need to enter a password. For information about how to enter a password, see "◆ Entering the administrator password".

◆ Entering the administrator password

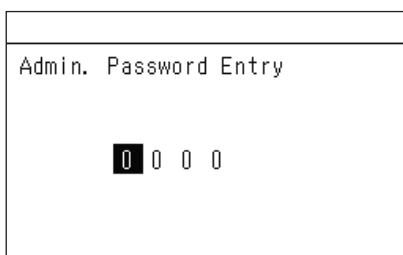

1 In the **Admin. Password Entry** screen, select where to enter the password using [**<**] and [**>**], and change the number by pressing [**↑**] and [**↓**].

2 After entering the administrator password, press [**●**] (**Confirm**).

Operation after filter cleaning (Filter Sign Reset)

Depending on the range of the area to be cancelled, display and operate the “Control” screen of All, Zone, or Unit.
 After cleaning the filter, perform Filter Sign Reset and cancel the Filter Sign displayed on the screen.
 If you reset the time, the remaining time to clean the filter is also reset.
 If you reset the time when the Filter Sign is not displayed, the remaining time to clean the filter is reset.

•REQUIREMENT

After cleaning the filter, be sure to perform Filter Sign Reset.

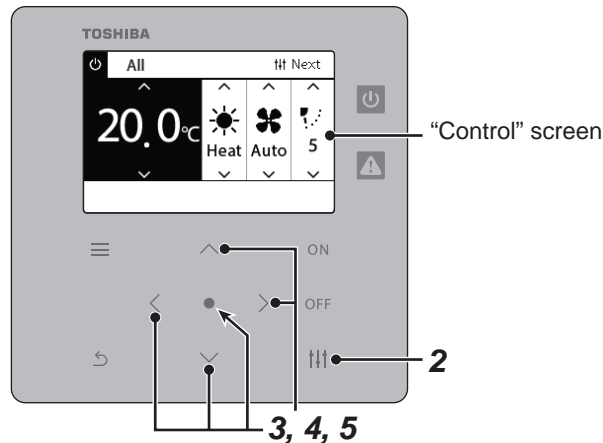

All Menu
1. Filter Sign Reset
2. Ventilation
3. Energy saving operation
4. Key lock
5. Louver setting in Group

Admin. Password Entry
0 0 0 0

Filter Sign Reset
Remaining time to clean filter. Are you sure you want to reset the time?
Reset

- 1** Display the **Control** screen of All, Zone, or Unit. (P.15)
- 2** Press [**Control**].
The “Menu” screen is displayed.
- 3** Use [**Up**] [**Down**] to select **Filter Sign Reset** , then press [**Confirm**].
The “Admin. Password Entry” screen is displayed.
- 4** Enter the 4 digit password then press [**Confirm**].
Press [**Left**] [**Right**] to select the digit and [**Up**] [**Down**] to select the number.
The “Filter Sign Reset” screen is displayed.
- 5** Press [**Confirm**].
“Reset Complete” is displayed. Press [**Return**] (Return) to return to the “Menu” screen.

Set the ventilation function, ventilation mode, and fan speed (Ventilation)

You can control the Air to air heat exchanger (indoor unit dedicated to ventilation) linked with the air conditioner. Depending on the range of the area to be set, display the “Control” screen of All, Zone, or Unit and perform the operation.

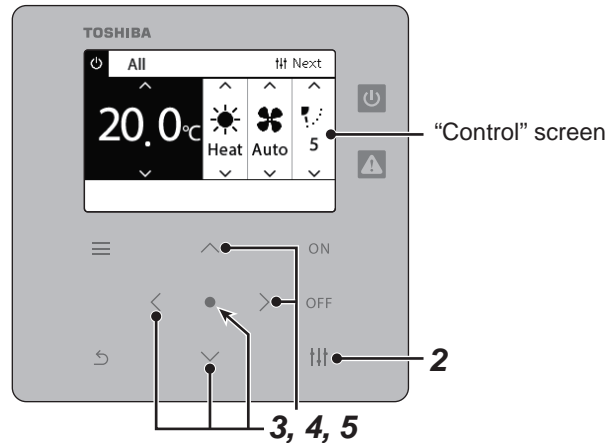

Ventilation ON/OFF

All Menu
1. Filter Sign Reset
2. Ventilation
3. Energy saving operation
4. Key lock
5. Louver setting in Group

* When the Air to air heat exchanger is not connected, “No function” is displayed.

Ventilation
1. ON/OFF <ON>
2. Mode <Auto>
3. Fan speed <H>

ON/OFF
● ON
OFF

- 1** Display the **Control** screen of All, Zone, or Unit. (P.15)
- 2** Press [**|||**] (**Control**).
The “Menu” screen is displayed.
- 3** Press [**^**] [**v**] to select **Ventilation** , then press [**●**] (**Confirm**).
The “Ventilation” screen is displayed.
- 4** Press [**^**] [**v**] to select **ON/OFF** , then press [**●**] (**Confirm**).
The “ON/OFF” screen is displayed.
- 5** Press [**^**] [**v**] to select **ON** or **OFF** , then press [**●**] (**Confirm**).
Start or stop operation, then press [**↵**] (Return) to return to “Ventilation” screen.

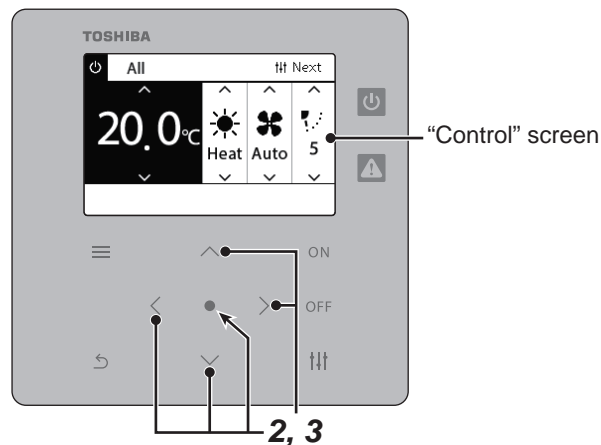

Ventilation Mode

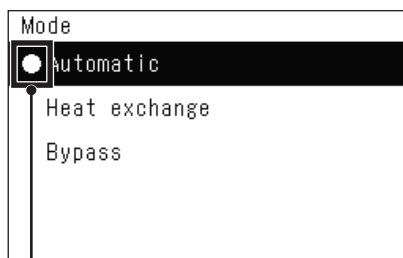

This mark indicates the current setting status.

- 1** Perform steps 1 to 3 of Ventilation ON/OFF . (P.49)
- 2** Press [^] [v] to select Mode , then press [●] (Confirm).
The “Mode” screen is displayed.
- 3** Press [^] [v] to select the ventilation mode, then press [●] (Confirm).
The selected Mode is set. Press [↵] (Return) to return to the “Ventilation” screen.

Icon	Setting items	Description
	Automatic	Heat exchange and Bypass are switched automatically.
	Heat exchange (Ht. Ex.)	Exchanging heat between the outdoor air and return air and making the temperature and humidity of the outdoor air closer to those of the return air before supplying it.
	Bypass	Outdoor air is taken into a room as it is.

Ventilation Fan speed

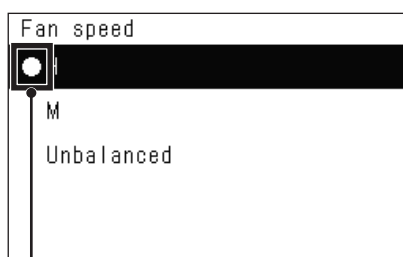

This mark indicates the current setting status.

- 1** Perform steps 1 to 3 of Ventilation ON/OFF . (P.49)
- 2** Press [^] [v] to select Fan speed , then press [●] (Confirm).
The “Fan speed” screen is displayed.
- 3** Press [^] [v] to select the fan speed, then press [●] (Confirm).
The selected fan speed is set. Press [↵] (Return) to return to the “Ventilation” screen.

Setting items	Description
H	Set a powerful Fan speed.
M	Set a gentle Fan speed.
Unbalanced	Set an unbalanced intake and exhaust volume.

Limit the output of the air conditioner (Energy saving operation)

Energy-saving operation that limits the output of the air conditioner is possible. Depending on the range of the area to be set, display the “Control” screen of All or Zone and perform the operation.

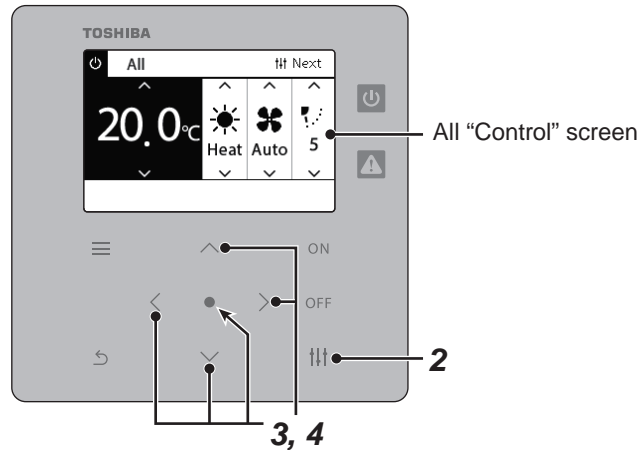

All Menu
1. Filter Sign Reset
2. Ventilation
3. Energy saving operation
4. Key lock
5. Louver setting in Group

Energy saving operation
● Release
Maximum
50%
0%

- 1** Display the Control screen of All or Zone. (P.15)
- 2** Press [Control].
The “Menu” screen is displayed.
- 3** Press [Up] [Down] to select Energy saving operation , then press [Confirm].
The “Energy saving operation” screen is displayed.
- 4** Select the save rate using [Up] and [Down], and then press [Confirm].
The selected save rate is set. If you press [Return], the “Menu” screen is displayed again.

Setting items	Description
Release	Energy saving operation is not performed.
Maximum	Operate with the highest save rate. It operates at the save rate set by the remote control.
50%	Operate at 50% save rate.
0%	Operate at thermo-off (Fan).

NOTE

Since the output of the air conditioners is limited in energy saving operation, they may not cool (warm) strongly.

Lock the local remote control operation (Key lock)

You can restrict button operation of the remote controls connected to each air conditioner. Depending on the range of the area to be set, display the "Control" screen of All, Zone, or Unit and perform the operation.

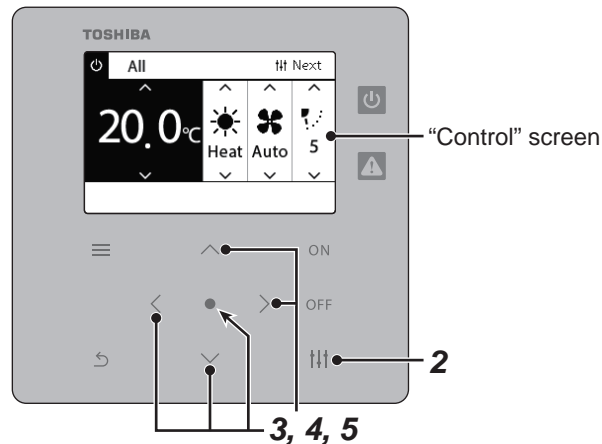

All Menu
1. Filter Sign Reset
2. Ventilation
3. Energy saving operation
4. Key lock
5. Louver setting in Group

Key lock
● Unlock
Lock1:ON/OFF
Lock2:ON/OFF, Mode, Set Temp.
Lock3:Mode, Set Temp.
Lock4:Mode

1 Display the **Control** screen of All, Zone, or Unit. (P.15)

2 Press [⏻] (**Control**).
The "Menu" screen is displayed.

3 Press [⏮] [⏭] to select **Key lock**, then press [●] (**Confirm**).
The "Key lock" screen is displayed.

4 Press [⏮] [⏭] to select the item you wish to set, then press [●] (**Confirm**).
The selected item is set. Press [↵] (Return) to return to the "Menu" screen.

Icon	Setting items	Function prohibited for remote control		
		ON/OFF	Operation Mode	Set temperature
None	Unlock	-	-	-
	Lock 1	○	-	-
	Lock 2	○	○	○
	Lock 3	-	○	○
	Lock 4	-	○	-
	Lock:Other	Displayed for a lock status other than the above.		

NOTE

- is displayed when the lock status is mixed in all air conditioners or in multiple air conditioners in a zone or when any lock other than the four patterns above is set by the central controller.
- The number of air conditioners for which "Key lock" is set for "Lock" on the "All" screen is displayed.

Make all the louver settings in the group at once (Louver setting in Group)

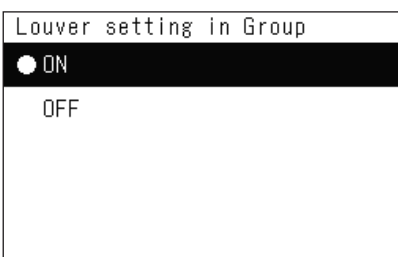
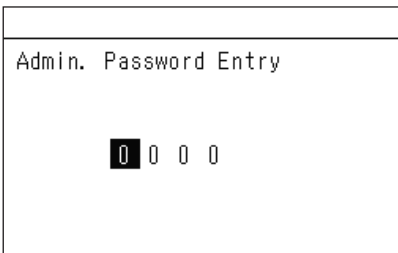
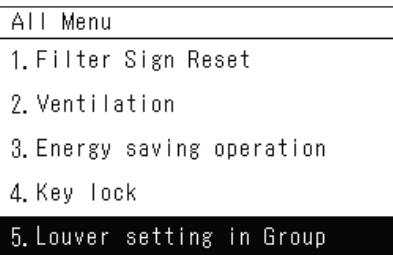

1 Display the **Control** screen of All, Zone, or Unit (P.15)

2 Press [**↑↑↑**] (**Control**)

The "Menu" screen is displayed.

3 Select **Louver setting in Group** using [**^**] and [**v**], and then press [**●**] (**Confirm**).

The "Admin. Password Entry" screen is displayed.

4 Enter a 4-digit password, and then press [**●**] (**Confirm**).

Select the digit position using [**<**] and [**>**], and select a number using [**^**] and [**v**].

The "Louver setting in Group" screen is displayed.

5 Select **ON** or **OFF** using [**^**] and [**v**], and then press [**●**] (**Confirm**).

If you press [**↵**] (Return), the "Menu" screen is displayed again.

- By default, "ON" is set.

• NOTE

Group (Group control): Up to 16 indoor units can be controlled with a single local remote control. Set "OFF" if you do not want to the louver of the follower unit to be linked.

5-2. Air to Water Heat Pump

Setting the Operation Details

You can check the current settings of the air conditioner or ON/OFF device and set the details of the operation method.

◆ Displaying the Menu screen

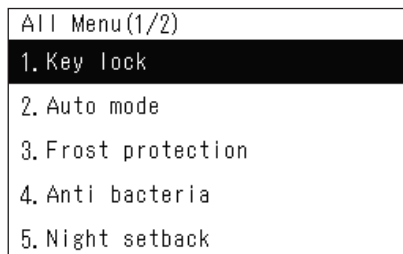
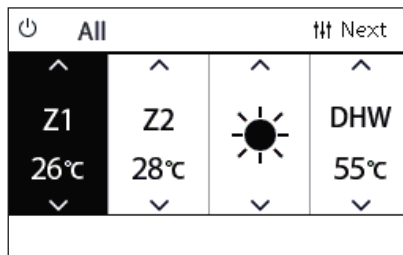

1 Display the **Control** screen of **All, Zone, or Unit (P.16)**.

2 Press [**↑↑↑**] (**Control**).
The “Menu” screen is displayed.

3 Select an item using [**▲**] and [**▼**], and then press [**●**] (**Confirm**).

For the checks and settings of the individual items, see below.
The displayed items differ depending on the control range.

◆ Menu items

Setting items	Description	Page to see
Auto mode	The setting temperature can be set automatically according to the outside temperature.	P.55
Frost protection	This function performs operation with the minimum capacity (target water temperature:15°C) to prevent pipes from freezing in case the unit is not used for a long period due to absence.	P.55
Anti bacteria	This setting regularly raises the hot water cylinder temperature to prevent bacteria from growing.	P.56
Night setback	This function is used for energy saving during specified time zone (sleeping hours, etc.).	P.56
Unit information	Shows the model names and serial numbers.	P.57

Auto mode

Unit Menu(1/2)
1. Key lock
2. Auto mode
3. Frost protection
4. Anti bacteria
5. Night setback

Auto mode
ON
● OFF

- 1** Display the **Control** screen of All, Zone, or Unit. (P.16)
- 2** Press [↑↑] (**Control**).
The "Menu" screen is displayed.
- 3** Select **Auto mode** using [^] and [v], and then press [●] (**Confirm**).
The "Auto mode" screen is displayed.
- 4** Select **ON** or **OFF** using [^] and [v], and then press [●] (**Confirm**).
If you press [↵] (Return), the "Menu" screen is displayed again.

● NOTE

This is enabled only during water temperature control.

Frost protection

Unit Menu(1/2)
1. Key lock
2. Auto mode
3. Frost protection
4. Anti bacteria
5. Night setback

Frost protection
ON
● OFF

- 1** Display the **Control** screen of All, Zone, or Unit. (P.16)
- 2** Press [↑↑] (**Control**).
The "Menu" screen is displayed.
- 3** Select **Frost protection** using [^] and [v], and then press [●] (**Confirm**).
The "Frost protection" screen is displayed.
- 4** Select **ON** or **OFF** using [^] and [v], and then press [●] (**Confirm**).
If you press [↵] (Return), the "Menu" screen is displayed again.

Anti bacteria

Unit Menu(1/2)
1. Key lock
2. Auto mode
3. Frost protection
4. Anti bacteria
5. Night setback

Anti bacteria
ON
● OFF

- 1** Display the **Control** screen of All, Zone, or Unit. (P.16)
- 2** Press [↑↑] (**Control**).
The "Menu" screen is displayed.
- 3** Select **Anti bacteria** using [^] and [v], and then press [●] (**Confirm**).
The "Anti bacteria" screen is displayed.
- 4** Select **ON** or **OFF** using [^] and [v], and then press [●] (**Confirm**).
If you press [↵] (Return), the "Menu" screen is displayed again.

Night setback

Unit Menu(1/2)
1. Key lock
2. Auto mode
3. Frost protection
4. Anti bacteria
5. Night setback

Night setback
ON
● OFF

- 1** Display the **Control** screen of All, Zone, or Unit. (P.16)
- 2** Press [↑↑] (**Control**).
The "Menu" screen is displayed.
- 3** Select **Night setback** using [^] and [v], and then press [●] (**Confirm**).
The "Night setback" screen is displayed.
- 4** Select **ON** or **OFF** using [^] and [v], and then press [●] (**Confirm**).
If you press [↵] (Return), the "Menu" screen is displayed again.

Unit Information

```
Unit Menu(2/2)
6. Unit Information
```

```
Unit Information
Model
  XXX-XXXXXXXXXX
Serial number
  XXXXXXXXXXXXXXXX
```

- 1** Display the **Control** screen of Unit. (P.16)
- 2** Press [↑↑] (**Control**).
The "Menu" screen is displayed.
- 3** Select **Unit Information** using [^] and [v], and then press [●] (**Confirm**).
The "Unit Information" screen is displayed.
- 4** Select **ON** or **OFF** using [^] and [v], and then press [●] (**Confirm**).
If you press [↵] (Return), the "Menu" screen is displayed again.

• NOTE

This is only displayed in the Unit Menu.

Administrator Menu

Renaming a zone (Zone Name Settings)

Zone Name Settings	
1 ZONE-1	6 ZONE-6
2 ZONE-2	7 ZONE-7
3 ZONE-3	8 ZONE-8
4 ZONE-4	9 ZONE-9
5 ZONE-5	10 ZONE-10

- 1 In the Settings Menu screen, select Zone Name Settings and then press [●] (Confirm).**

The "Admin. Password Entry" screen is displayed.

- 2 Enter a password using [<], [^], [v], and [>], and then press [●] (Confirm).**

The "Zone Name Settings" screen is displayed.

- 3 Select the zone to change using [<], [^], [v], and [>], and then press [●] (Confirm).**

The "Character entry" screen is displayed.

- Delete the default name displayed at the top of the screen before entering characters.

ZONE-1	
ABCDE abcde 12345	Del
FGHIJ fghij 67890	
KLMNO klmno -+!?	
PQRST qrst .# 0	
UVWXY uvwxy	
Z z	
Fix	

- 4 Select characters using [<], [^], [v], and [>], and then press [●] (Confirm).**

The selected characters are displayed at the top of the screen.

- Up to 9 characters can be entered.

Room	
ABCDE abcde 12345	Del
FGHIJ fghij 67890	
KLMNO klmno -+!?	
PQRST qrst .# 0	
UVWXY uvwxy	
Z z	
Fix	

- 5 Repeat step 4, select Fix , and then press [●] (Confirm).**

The zone name is changed to the one you have set, and the "Zone Name Settings" screen is displayed again.

- If you press [↵] (Return) without pressing "Fix", the setting is cancelled and the screen returns to the state it was in before the change was made.

ZONE-	
ABCDE abcde 12345	Del
FGHIJ fghij 67890	
KLMNO klmno -+!?	
PQRST qrst .# 0	
UVWXY uvwxy	
Z z	
Fix	

Deleting a character

Select Del , and then press [●] (Confirm).

The last character is deleted.

Changing the screen display (Screen Display Settings)

Screen Display Settings
1. Language
2. Screen Contrast
3. Backlight

- 1 In the Settings Menu screen, select Screen Display Settings and then press [●] (Confirm).**

The “Screen Display Settings” screen is displayed.

- 2 Select an item using [^] and [v], and then press [●] (Confirm).**

The screen corresponding to the selected item is displayed.

Language

Language (1/3)	
● English	English
Chinese	简体中文
French	Français
Spanish	Español
Italian	Italiano

- 1 Select Language using [^] and [v], and then press [●] (Confirm).**

The “Language” screen is displayed.

- “●” indicates the currently set item.

- 2 Select the language using [^] and [v], and then press [●] (Confirm).**

The selected language is set.

- If you press [↵] (Return), the “Screen Display Settings” screen is displayed again.

Screen Contrast

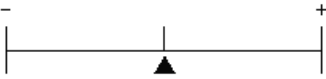
Screen Contrast

<ul style="list-style-type: none"> • Confirm ↵ Return

- 1 Select Screen Contrast using [^] and [v], and then press [●] (Confirm).**

The “Screen Contrast” screen is displayed.

- 2 Move ▲ using [<] and [>], and then press [●] (Confirm).**

The adjusted contrast is set.

- If you press [↵] (Return), the “Screen Display Settings” screen is displayed again.

Backlight

Backlight
● ON 15second (s)
ON 30second (s)
OFF

- 1 Select Backlight using [^] and [v], and then press [●] (Confirm).**

The “Backlight” screen is displayed.

- “●” indicates the currently set item.

- 2 Select the duration of the backlight remaining on using [^] and [v], and then press [●] (Confirm).**

The selected item is set.

- If you press [↵] (Return), the “Screen Display Settings” screen is displayed again.

Changing a button operation (Button Settings)

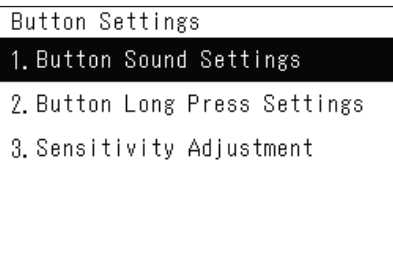

- 1 In the Settings Menu screen, select Button Settings and then press [●] (Confirm).**

The “Button Settings” screen is displayed.

- 2 Select an item using [^] and [v], and then press [●] (Confirm).**

The screen corresponding to the selected item is displayed.

Button Sound Settings

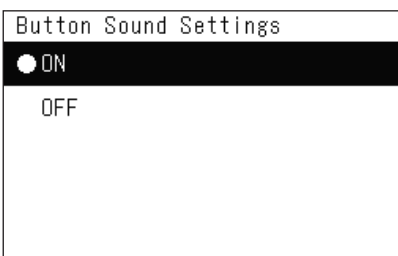

- 1 Select Button Sound Settings using [^] and [v], and then press [●] (Confirm).**

The “Button Sound Settings” screen is displayed.

- “●” indicates the currently set item.

- 2 Select ON (sound) or OFF (do not sound) using [^] and [v], and then press [●] (Confirm).**

The selected item is set.

- If you press [↵] (Return), the “Button Settings” screen is displayed again.

Button Long Press Settings

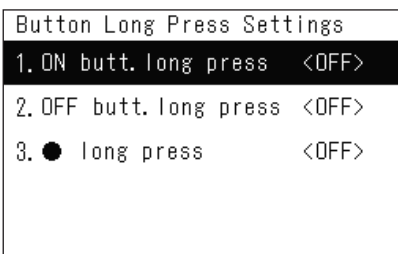

- 1 Select Button Long Press Settings using [^] and [v], and then press [●] (Confirm).**

The “Button Long Press Settings” screen is displayed.

- The current setting is displayed in < >.

- 2 Select ON butt. long press using [^] and [v], and then press [●] (Confirm).**

The “ON butt. long press” screen is displayed.

- You can also set “OFF butt. long press” and “● long press” using the same procedure.

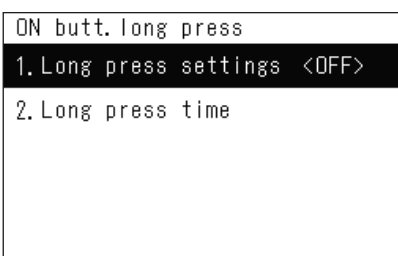

- 3 Select Long press settings using [^] and [v], and then press [●] (Confirm).**

The “ON/OFF setting” screen is displayed.

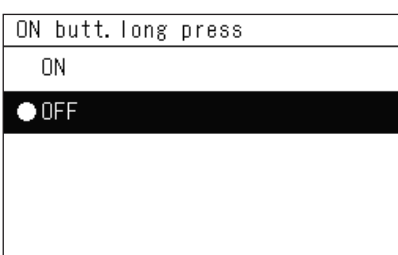

- 4 Select ON or OFF using [^] and [v], and then press [●] (Confirm).**

The selected item is set.

- If you press [↵] (Return), the “ON butt. long press” screen is displayed again.

◆ When ON is set for Button Long Press Settings

If you set "ON", set the long press time as well.

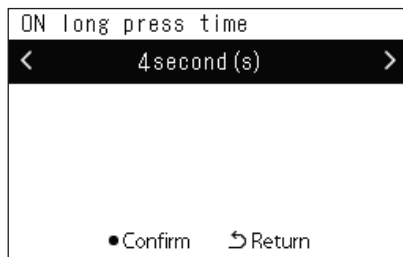

- 1** Display the **ON butt. long press** screen (Steps 1 and 2 of **Button Long Press Settings** (P.60)).
- 2** Select **Long press time** using [**^**] and [**v**], and then press [**●**] (**Confirm**).
The "ON long press time" screen is displayed.
- 3** Select the number of seconds (1 to 5 seconds) using [**<**] and [**>**], and then press [**●**] (**Confirm**).
The selected number of seconds is set as the ON long press time.
 - If you press [**↵**] (Return), the "ON butt. long press" screen is displayed again.

Sensitivity Adjustment

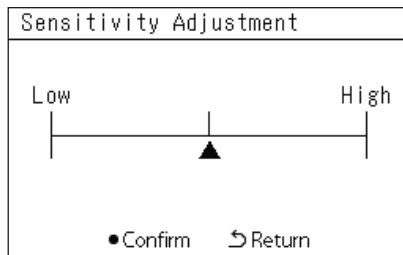

- 1** In the **Settings Menu** screen, select **Button Settings** and then press [**●**] (**Confirm**).
The "Button Settings" screen is displayed.
- 2** Select **Sensitivity Adjustment** using [**^**] and [**v**], and then press [**●**] (**Confirm**).
The "Sensitivity Adjustment" screen is displayed.
- 3** Move **▲** using [**<**] and [**>**], and then press [**●**] (**Confirm**).
The adjusted sensitivity is set.
 - If you press [**↵**] (Return), the "Button Settings" screen is displayed again.

Checking the Check / Notice history (Check/Notice history)

Check/Notice history
1. Check history
2. Notice history
3. Contact Information

1 In the **Settings Menu** screen, select **Check/Notice history** and then press **[●] (Confirm)**.

The "Admin. Password Entry" screen is displayed.

2 Enter a password using **[<]**, **[^]**, **[v]**, and **[>]**, and then press **[●] (Confirm)**.

The "Check/Notice history" screen is displayed.

3 Select an item using **[^]** and **[v]**, and then press **[●] (Confirm)**.

The screen corresponding to the selected item is displayed.

Check history

Check history				
No.	YY/MM/DD	Time	Address	Code
1	20/02/25	07:30	002-001	C06
2	20/02/25	07:29	002-002	C06
3	20/02/25	07:29	128-003	C06
4	20/02/22	12:10	029-003	E04
5	20/02/20	12:00	029-003	E04
6	20/02/19	22:20	029-004	P20

The Check history of the past 300 Check codes is displayed.

- Change the page using **[^]** and **[v]**.
- If you press **[↵] (Return)**, the "Check/Notice history" screen is displayed again.
- The Check code for the occurring check is blinking.

3/4-digit code

***: Air conditioner (LC/VRF/Air to air heat exchanger/General purpose equipment control interface)

3***: Air to Water Heat Pump

Notice history

Notice History				
No.	YY/MM/DD	Time	Address	Code
1	21/02/25	07:30	003-002	200
2	21/02/25	07:29	128-003	001
3	21/02/25	07:29	003-003	363
4	21/02/22	12:10	029-003	300
5	21/02/20	12:00	029-003	300
6	21/02/19	22:20	029-004	350

The Notice history of the past 300 Notice codes is displayed.

- Change the page using **[^]** and **[v]**.
- If you press **[↵] (Return)**, the "Check/Notice history" screen is displayed again.
- The Notice code for the occurring notice is blinking.

Contact information

Contact Information
TEL
012-345-6789

The Contact Information is displayed.

- If you press **[↵] (Return)**, the "Check/Notice history" screen is displayed again.
- For information about how to register contact information, refer to the installation manual.

Changing the administrator password (Admin. Password Settings)

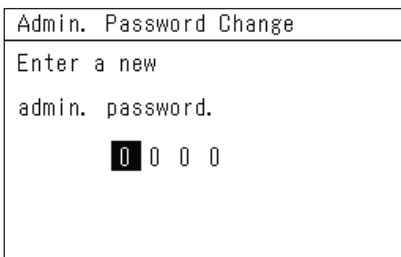
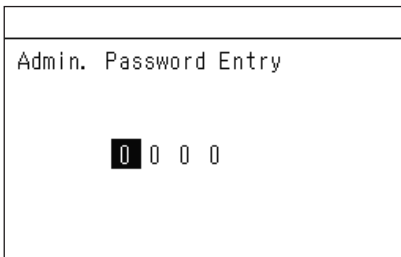

- 1** In the **Settings Menu** screen, select **Admin. Password Settings** and then press **[●] (Confirm)**.
The “Admin. Password Entry” screen is displayed.
- 2** Enter a password using **[<]**, **[^]**, **[v]**, and **[>]**, and then press **[●] (Confirm)**.
The “Admin. Password Change” screen is displayed.
- 3** Enter a new password using **[<]**, **[^]**, **[v]**, and **[>]**, and then press **[●] (Confirm)**.
The new password is set, and the “Settings Menu” screen is displayed again.
 - The default administrator password is set to “0000”.

Checking the device information (Information)

You can check the model and software version of this device.

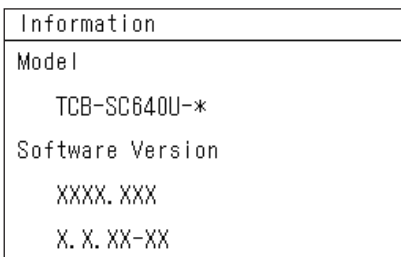

- In the Settings Menu screen, select Information and then press [●] (Confirm).**
The model and software version are displayed.
- If you press **[↵] (Return)**, the “Settings Menu” screen is displayed again.

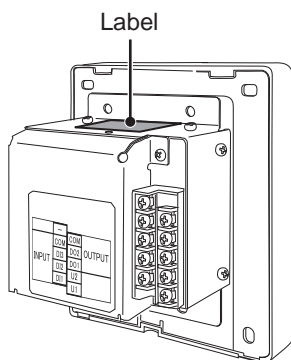

“*” in the model name represents the product series name. See the table below.
For the model, see the label.

Destination	Model
Global	TCB-SC640U-E
Turkey	TCB-SC640U-TR
Middle East	TCB-SC640U-ME

Troubleshooting

The following cases are not faults with the Unit.

Problem	Cause
When an air conditioner is stopped, its operation status is displayed on the LCD display part of the Central remote controller.	If you stop the air conditioner using the local remote control, it may take time before the operation is reflected on the Central remote controller.
The display does not switch even if you operate the Central remote controller.	When the Central remote controller is set to the Local Control Mode, you cannot operate it if key lock is set from another central control device.
It is not set even when operating the Central remote controller.	Even if you can configure the settings on the Control screen of All or Zone, the controller does not operate when the air conditioner does not have the corresponding function.
The schedule is set, but the device does not operate.	Is the clock not blinking (not set) Set the clock. The clock is initialized if power is not supplied for a long period of time.
A button is pressed, but there is no reaction.	<ul style="list-style-type: none"> • If you press any button while the backlight is off, the backlight turns on. Press the button you want to operate again. • The operation is disabled for the button. (The buzzer does not sound.)

Please check the following before requesting service.

Problem	Cause	Solution
The air conditioner does not operate even if the ON/OFF button of the Central remote controller is pressed.	Isn't the unit being started or set	If the LCD of the Central remote controller is not on, press the ON/OFF button again after energizing the controller.
The check lamp of the Central remote controller lights up.	Isn't the air conditioner protection device operating	Refer to the air conditioner operation manual and check its operation.
The LCD display part of the Central remote controller shows  (abnormality) and the check code S01.	Isn't a power outage affecting the air conditioner	The displayed information disappears a few minutes after power is restored to the air conditioner.

If you have investigated the above and there is still an abnormality, contact the dealer from whom you purchased the unit with the part number and problem.

Under no circumstances conduct repairs by yourself. Doing so is dangerous.

If the LCD display part of the Central remote controller shows  (abnormality) and a check code, inform the dealer of the displayed information as well.

Appendix

Specifications

Power supply	220-240 V AC 50/60Hz
Consumed current	0.06 A
Operating temperature and humidity ranges	0~40°C 10~90% (no condensation)
Dimensions	H: 120 × W: 120 × D: 20 (+ 50.6) mm
Weight	550 g
Number of connected units	Max. 64 groups (64 units)
LCD	Full-dot liquid crystal with backlights
External output	2 points (Run, Alarm)
External input	3 points (ON, OFF, Emergency system, Night Operation, Locking, Thermo OFF, Power peak cut)

Function list (Air conditioner)

Main functions		Main functions				
Control	ON/OFF	Operating Schedule	Setting target: Zone			
	Operation Mode		Setting unit: Day of week			
	Set temperature		Setting range: 6 weeks			
	Fan speed		Special day: 2 options			
	Louver		Setting time: 00:00 to 23:59			
	Key lock		Setting content	ON/OFF		
	Ventilation ON/OFF			Set temperature		
	Ventilation mode			Operation mode		
	Ventilation Fan speed			Key lock		
	Energy saving operation		Maximum number of schedules per day: 8	Energy-saving Schedule	Setting target: Zone	
	Filter Sign Reset		Setting unit: Day of week		Setting range: 1 weeks	
Monitor	ON/OFF	Setting time: 00:00 to 23:59	Setting content		Save rate	
	Operation Mode	Maximum number of schedules per day: 8	External input		Number of points	3
	Set temperature	Functions			ON	
	Fan speed				OFF	
	Louver			Emergency system		
	Key lock			Night Operation		
	Ventilation ON/OFF			Locking		
	Ventilation mode			Thermo OFF		
	Ventilation Fan speed		Power peak cut			
	Energy saving operation	External output	Number of points	2		
	Filter Sign		Functions	Run		
Check code	Alarm					
Notice code						

Function list (Air to Water Heat Pump)

Main functions	
Control	ON/OFF
	Operation Mode
	Set temperature
	Key lock
Monitor	ON/OFF
	Operation Mode
	Set temperature
	Key lock
	Check code

Main functions			
Operating Schedule	Setting target: Zone		
	Setting unit: Day of week		
	Setting range: 6 weeks		
	Special day: 2 options		
	Setting time: 00:00 to 23:59		
	Setting content	ON/OFF	
		Set temperature	
		Operation mode	
		Key lock	
	Maximum number of schedules per day: 8		
External input	Number of points	3	
	Functions	ON	
		OFF	
		Emergency system	
		Night Operation	
Locking			
External output	Number of points	2	
	Functions	Run	
		Alarm	

Toshiba Carrier Corporation

72-34 Horikawa-cho, Saiwai-ku, Kawasaki-shi, Kanagawa 212-8585, JAPAN

Copyright © 2021 TOSHIBA CARRIER CORPORATION ALL Rights Reserved

Revision history

Date	Chapter number	Content
Nov., 2020	-	-
Oct., 2021	-	Added mention of Air to Water Heat Pump.
	3-5	Added description of an operation procedure to be performed at the end of "DN setting".
	4	Added description of troubleshooting.
	5	Added Check Code List.
	-	Updated Installation Manual and Owner's Manual.