

Model name:

BMS-IFKX0TLR-E

KN Interface

KNX Interface for Toshiba AIR-CONDITIONER

User Manual
Issue Date: 02/07/2018

© TOSHIBA CARRIER EUROPE S.A.S 2018 ALL Rights Reserved.

Information in this document is subject to change without notice. No part of this publication may be reproduced, stored in a retrieval system or transmitted in any form or any means electronic or mechanical, including photocopying and recording for any purpose other than the purchaser's personal use without the written permission of TOSHIBA CARRIER EUROPE S.A.S

TRADEMARKS

All trademarks and tradenames used in this document are acknowledged to be the copyright of their respective holders.

1. Presentation	4
2. Specifications	5
3. Installation instructions	6
4. Object Table	8
4.1 Control	8
4.2 Status	17
5. Precautions	27
5.1 If the remote controller is not installed	27
5.2 "Permit/Prohibit of local" setting	27
5.3 Louver setting	27
5.4 4-way louver setting	27
5.5 Auto-cooling/Auto-heating setpoint	27
5.6 When alarm code remains at (-4)-initialization	27
5.7 Temperature setting unit of 1°C or 0.5°C (indoor unit)	28
5.8 Ventilation functions	28
5.9 Fan speed status	28
5.10 Louver status	28
5.11 Total enthalpy heat exchange unit status	29
6. Setting Using ETS Tool	30
6.1 How to obtain the ETS database	30
6.2 ETS Parameters	30
7. Check Code	41

1. Presentation



The BMS-IFKX0TLR-E interface allows a complete and natural integration of Toshiba air conditioners into KNX networks.

The BMS-IFKX0TLR-E is compatible with the Toshiba Remote controller AB lines.

- Reduced dimensions, quick installation.
- Multiple objects for control and status (bit, byte, characters...) with KNX standard datapoint types.
- Status objects for every control available.
- Direct connection to the Indoor unit.
- The Toshiba Indoor Unit can be controlled simultaneously by the wired remote controller of the indoor unit and by KNX.
- Control and Monitoring of the Indoor Unit from KNX, including monitoring of Indoor Unit's state of internal variables and error indication and error code.

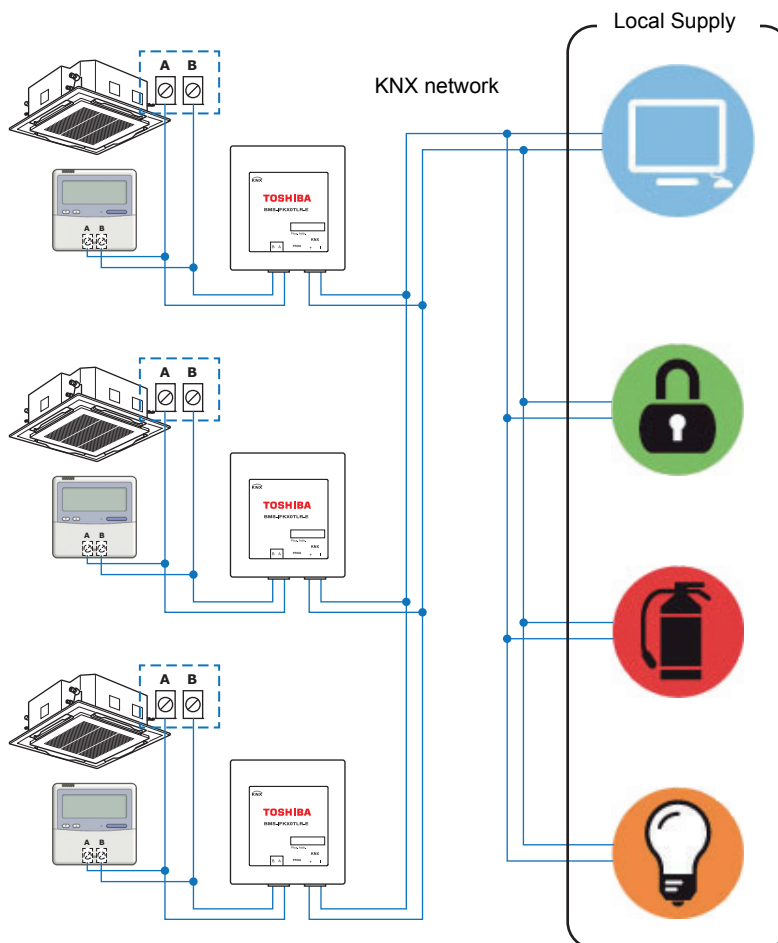

2. Specifications

Item	Specification value
Power supply	KNX line 29 VDC / 8 mA AB line 14 VDC / 20 mA
Operating temperature and humidity ranges	0 °C to 40 °C 10 to 80% RH (non-condensing)
Storage temperature and humidity ranges	-20 °C to 60 °C 10 to 80% RH (non-condensing)
Housing materials	Sheet metal box Galvanized sheet iron (SGCC-CSC) Base 0.8 t Cover 0.6 t No paint finish Mold unit ABS (UL 94 HB) 2.5 mm thick
Size	Sheet metal box 33.4 (H) x 82.5 (W) x 92.1 (D) mm Mold unit 28 (H) x 70 (W) x 70 (W)
Weight	225 g (including sheet metal box) 70 g (mold unit)

Supplied items

No.	Part name	Quantity	Remark
1	KN interface (mold unit)	1	
2	Installation Manual	1	
3	Sheet metal box	1	Cover, base
4	Fixing screws		

Use the following wiring materials to connect the signal lines. (Procure locally)

No.	Cable	Item	Value
1	For KNX TP-1 Bus	Cable type	KNX TP1
		Cable diameter	
		Cable length	1000m
		Polarity	Yes (+/-)
2	For AB Bus(TCC-LINK) lines	Cable type	VCTF
		Cable diameter	0.5mm ² -2.0mm ²
		Cable length	300m (0.75 ²)
		Polarity	No

Power supply

The following two types of power supplies are required for the power supplies of this product.

No.	Power supply	Remark
1	KNX TP-1 Bus	Supplies power from the KNX power unit (procure locally) using the KNX link cable.
2	AB Bus(TCC-LINK) lines	Supplies power from the indoor unit using the AB Bus cable.

3. Installation instructions

- Disconnect the Indoor unit from Mains Power.
- Disconnect the power supply of the KNX bus.
- Connect the connection cable between the interface and the Indoor unit following the instructions of the diagram below.
- Connect the KNX bus to the connector KNX of the interface. Respect the polarity.
- Close the Indoor unit and reconnect it to Mains Power.
- Reconnect power supply to the KNX bus.
- Follow the instructions on the user's manual for configuring and commissioning the interface. See below how to obtain the user's manual and the ETS database.

NOTE

The cable used for connection of BMS-IFKX0TLR-E to A B bus can be any two-core cable, the maximum distance for bus A B is 300 meters, consult the manual of the Air-conditioning for more details.

IMPORTANT:

- Use only one remote controller. A sub-remote controller cannot be connected when connecting this interface.

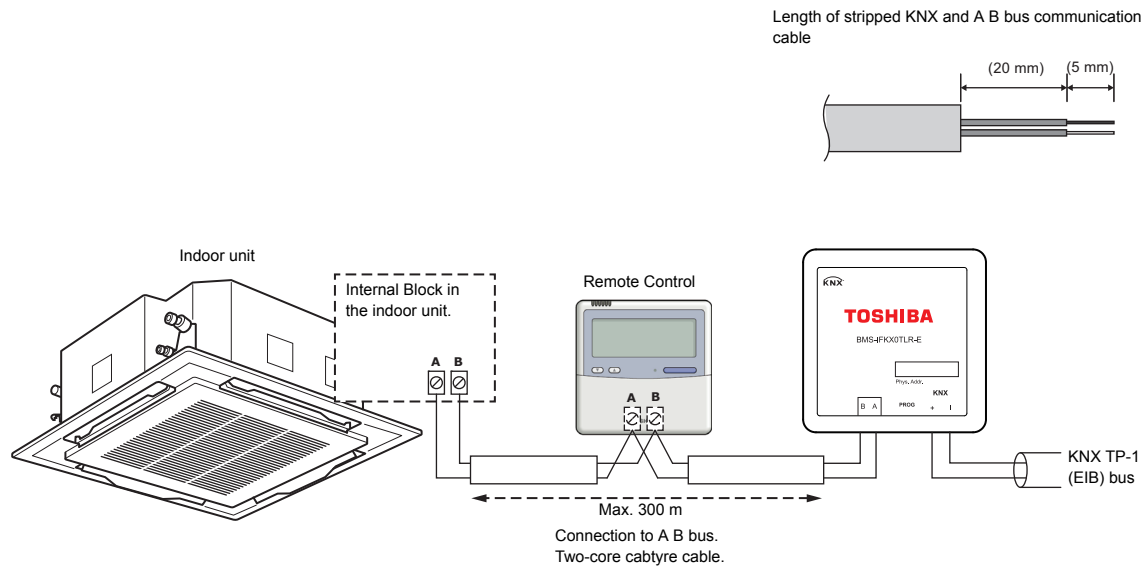

NOTE

In its place there is a pair of cables to connect the Remote Controller. Use these cables to connect the AB bus. Check your Air-Conditioning user or service manual for more information.

Dimensions

External dimensions

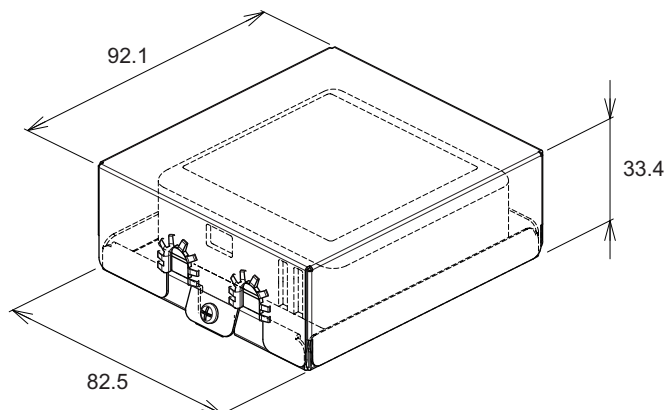

Wall mount

During installation, secure the metal plate and mold case (bottom) together with screws.
 After wiring, attach the mold case (top), install the metal plate cover, and secure with a screw.

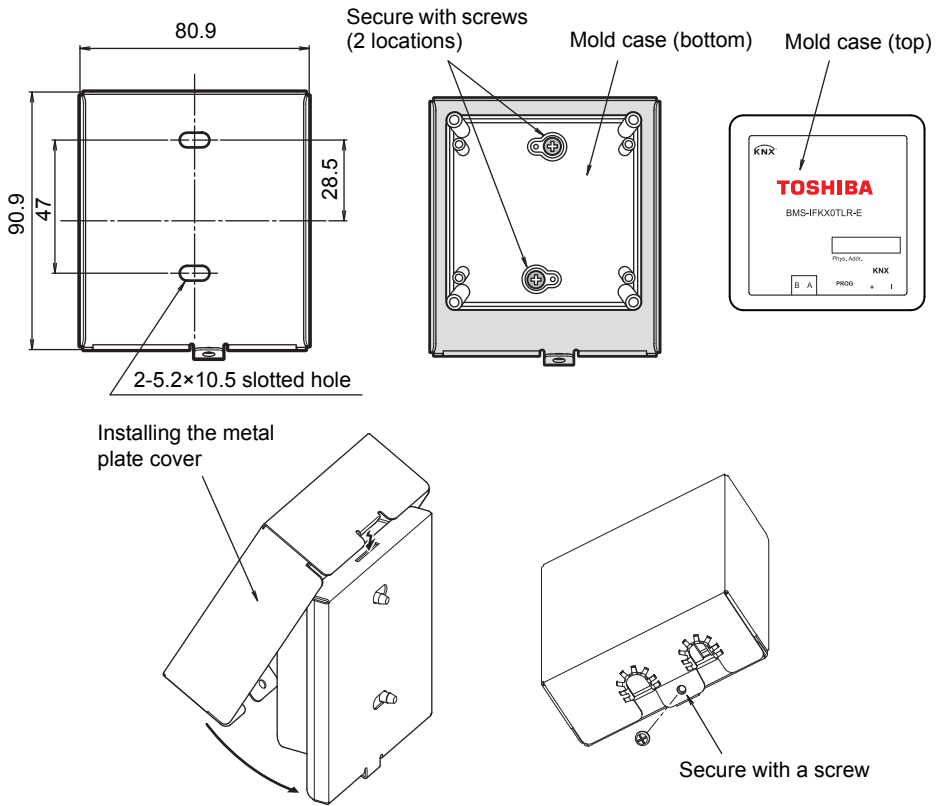

NOTE

When installing the interface on the plane surface instead of mounting it on the wall and securing with screws, secure the unit with double-sided adhesive tape or similar stuff.

Connections

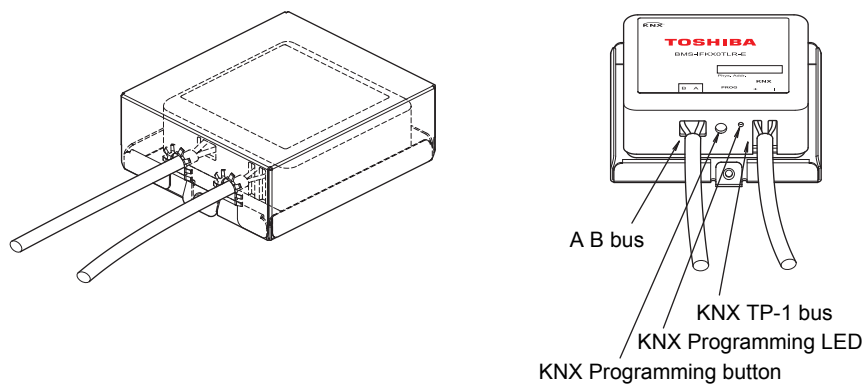

4. Object Table

The following describes the KNX objects used to control the indoor unit and acquire status from it. Note that some of the objects may not be available depending on the model of the indoor unit and DN setting.

4.1 Control

FUNCTION	OBJECT NUMBER	Name	Value	Length	Datapoint Type		Flags					Priority
					Data Type Name	DPT_ID	C	R	W	T	U	
On/Off	0	Control_On/Off	0-Off;1-On	1 bit	switch	DPT_1.001	C	-	W	T	U	Low
Mode	1	Control_Mode	0-Auto;1-Heat;3-Cool;9-Fan;14-Dry	1 byte	HVAC control mode	DPT_20.10	C	-	W	T	U	Low
	2	Control_Mode Cool/Heat	0-Cool;1-Heat	1 bit	cooling/heating	DPT_1.100	C	-	W	T	U	Low
	3	Control_Mode Cool & On	0%-Off;100%-On+Cool	1 byte	percentage (0..100%)	DPT_5.001	C	-	W	T	U	Low
	4	Control_Mode Heat & On	0%-Off;100%-On+Heat	1 byte	percentage (0..100%)	DPT_5.001	C	-	W	T	U	Low
	5	Control_Mode Auto	1-Set AUTO mode	1 bit	boolean	DPT_1.002	C	-	W	T	U	Low
	6	Control_Mode Heat	1-Set HEAT mode	1 bit	boolean	DPT_1.002	C	-	W	T	U	Low
	7	Control_Mode Cool	1-Set COOL mode	1 bit	boolean	DPT_1.002	C	-	W	T	U	Low
	8	Control_Mode Fan	1-Set FAN mode	1 bit	boolean	DPT_1.002	C	-	W	T	U	Low
	9	Control_Mode Dry	1-Set DRY mode	1 bit	boolean	DPT_1.002	C	-	W	T	U	Low
	10	Control_Mode +/-	0-Decrease;1-Increase [Example] ①1-Increase HEAT→COOL→FAN→DRY→AUTO ②0-Decrease DRY→FAN→COOL→HEAT→AUTO	1 bit	step	DPT_1.007	C	-	W	-	-	Low
	11	Control_Mode +/-	0-Up;1-Down [Example] ①0-Up HEAT→COOL→FAN→DRY→AUTO ②1-Down DRY→FAN→COOL→HEAT→AUTO	1 bit	up/down	DPT_1.008	C	-	W	-	-	Low

FUNCTION	OBJECT NUMBER	Name	Value	Length	Datapoint Type		Flags					Priority
					Data Type Name	DPT_ID	C	R	W	T	U	
Fan	12	Control_ Fan Speed / N Speeds	Thresholds: $100 \cdot (n+0.5)/N \%$ ①3 Fan Speed (L,H,HH) L :0-49% H :50-82% HH:83-100% ②1Fan Speed (HH) HH:0-100% ③5Fan Speed (L,L+,H,H+,HH) L :0-29% L+:30-49% H :50-69% H+:70-89% HH:90-100%	1 byte	percentage (0..100%)	DPT_5.001	C	-	W	T	U	Low
	13	Control_ Fan Speed / N Speeds	Speed values: 1...N ①For fan speed 3 (L,H,HH) L:0-1, H:2, HH:3 or more ②For fan speed 1 (HH) HH:0 or more ③For fan speed 5 (L,L+,H,H+, HH) L:0-1, L+:2, H:3, H+:4, HH:5 or more	1 byte	counter pulses (0..255)	DPT_5.010	C	-	W	T	U	Low
	14	Control_ Fan Speed Man/Auto	0-Fanspeed 1;1-Auto	1 bit	boolean	DPT_1.002	C	-	W	T	U	Low
	15	Control_ Fan Speed 1	1-Set Fanspeed 1	1 bit	boolean	DPT_1.002	C	-	W	T	U	Low
	16	Control_ Fan Speed 2	1-Set Fanspeed 2	1 bit	boolean	DPT_1.002	C	-	W	T	U	Low
	17	Control_ Fan Speed 3	1-Set Fanspeed 3	1 bit	boolean	DPT_1.002	C	-	W	T	U	Low
	18	Control_ Fan Speed 4	1-Set Fanspeed 4	1 bit	boolean	DPT_1.002	C	-	W	T	U	Low
	19	Control_ Fan Speed 5	1-Set Fanspeed 5	1 bit	boolean	DPT_1.002	C	-	W	T	U	Low
	20	Control_ Fan Speed +/-	0-Decrease;1-Increase [Example] ①For fan speed 3 (L,H,HH)/Increase L→H→HH→Auto→L ②For fan speed 3 (L,H,HH)/Decrease L→Auto→HH→H→L	1 bit	step	DPT_1.007	C	-	W	-	-	Low

FUNCTION	OBJECT NUMBER	Name	Value	Length	Datapoint Type		Flags					Priority
					Data Type Name	DPT_ID	C	R	W	T	U	
	21	Control_ Fan Speed +/-	0-Up;1-Down [Example] ①For fan speed 3 (L,H,HH)/Up L→H→HH→Auto→L ②For fan speed 3 (L,H,HH)/Down L→Auto→HH→H→L	1 bit	up/down	DPT_1.008	C	-	W	-	-	Low
Louver	22	Control_ Louver / 5 Pos	Thresholds: 0, 30, 50, 70, 90% ①Heat and FAN (F1-F5) F1:0-29% F2:30-49% F3:50-69% F4:70-89% F5:90-100% ②Cool and Dry (F1-F3) F1:0-29% F2:30-49% F3:50-100%	1 byte	percentage (0..100%)	DPT_5.001	C	-	W	T	U	Low
	23	Control_ Louver / 5 Pos	Position values: 1,2,3,4,5 ①Heat and FAN (F1-F5) F1:0-1 F2:2 F3:3 F4:4 F5:5 or more ②Cool and Dry (F1-F3) F1:0-1 F2:2 F3:3 or more	1 byte	counter pulses (0..255)	DPT_5.010	C	-	W	T	U	Low
	24	Control_ Louver Stop	1-Stop	1 bit	boolean	DPT_1.002	C	-	W	T	U	Low
	25	Control_ Louver Pos 1	1-Set Position 1	1 bit	boolean	DPT_1.002	C	-	W	T	U	Low
	26	Control_ Louver Pos 2	1-Set Position 2	1 bit	boolean	DPT_1.002	C	-	W	T	U	Low
	27	Control_ Louver Pos 3	1-Set Position 3	1 bit	boolean	DPT_1.002	C	-	W	T	U	Low
	28	Control_ Louver Pos 4	1-Set Position 4	1 bit	boolean	DPT_1.002	C	-	W	T	U	Low
	29	Control_ Louver Pos 5	1-Set Position 5	1 bit	boolean	DPT_1.002	C	-	W	T	U	Low
30	Control_ Louver Swing	1-Swing	1 bit	boolean	DPT_1.002	C	-	W	T	U	Low	

FUNCTION	OBJECT NUMBER	Name	Value	Length	Datapoint Type		Flags					Priority
					Data Type Name	DPT_ID	C	R	W	T	U	
	31	Control_Louver +/-	0-Decrease;1-Increase [Example] ①1-Increase Swing→F1→F2→F3→F4→F5→STOP→Swing ②0-Decrease STOP→F5→F4→F3→F2→F1→Swing→STOP	1 bit	step	DPT_1.007	C	-	W	-	-	Low
	32	Control_Louver +/-	0-Up;1-Down [Example] ①0-Up Swing→F1→F2→F3→F4→F5→STOP→Swing ②1-Down STOP→F5→F4→F3→F2→F1→Swing→STOP	1 bit	up/down	DPT_1.008	C	-	W	-	-	Low
4-way Louver1	33	Control_Louver 4-way-1 / 5 Pos	Thresholds: 0, 30, 50, 70, 90% ①Heat and FAN (F1-F5) F1:0-29% F2:30-49% F3:50-69% F4:70-89% F5:90-100% ②Cool and Dry (F1-F3) F1:0-29% F2:30-49% F3:50-100%	1 Byte	percentage (0..100%)	DPT_5.001	C	-	W	T	U	Low
	34	Control_Louver 4-way-1 / 5 Pos	Position values: 1,2,3,4,5 ①Heat and FAN (F1-F5) F1:0-1 F2:2 F3:3 F4:4 F5:5 or more ②Cool and Dry (F1-F3) F1:0-1 F2:2 F3:3 or more	1 Byte	counter pulses (0..255)	DPT_5.010	C	-	W	T	U	Low
	35	Control_Louver 4-way-1 Stop	1-Stop	1 bit	boolean	DPT_1.002	C	-	W	T	U	Low

FUNCTION	OBJECT NUMBER	Name	Value	Length	Datapoint Type		Flags					Priority
					Data Type Name	DPT_ID	C	R	W	T	U	
	36	Control_Louver 4-way-1 Swing	1-Swing	1 bit	boolean	DPT_1.002	C	-	W	T	U	Low
	37	Control_Louver 4-way-1 -/+	0-Decrease;1-Increase	1 bit	step	DPT_1.007	C	-	W	T	U	Low
	38	Control_Louver 4-way-1 +/-	0-Up;1-Down	1 bit	up/down	DPT_1.008	C	-	W	T	U	Low
4-way Louver2	39	Control_Louver 4-way-2 / 5 Pos	Thresholds: 0, 30, 50, 70, 90% ①Heat and FAN (F1-F5) F1:0-29% F2:30-49% F3:50-69% F4:70-89% F5:90-100% ②Cool and Dry (F1-F3) F1:0-29% F2:30-49% F3:50-100%	1 bit	percentage (0..100%)	DPT_5.001	C	-	W	T	U	Low
	40	Control_Louver 4-way-2 / 5 Pos	Position values: 1,2,3,4,5 ①Heat and FAN (F1-F5) F1:0-1 F2:2 F3:3 F4:4 F5:5 or more ②Cool and Dry (F1-F3) F1:0-1 F2:2 F3:3 or more	1 Byte	counter pulses (0..255)	DPT_5.010	C	-	W	T	U	Low
	41	Control_Louver 4-way-2 Stop	1-Stop	1 bit	boolean	DPT_1.002	C	-	W	T	U	Low
	42	Control_Louver 4-way-2 Swing	1-Swing	1 bit	boolean	DPT_1.002	C	-	W	T	U	Low
	43	Control_Louver 4-way-2 -/+	0-Decrease;1-Increase	1 bit	step	DPT_1.007	C	-	W	T	U	Low
	44	Control_Louver 4-way-2 +/-	0-Up;1-Down	1 bit	up/down	DPT_1.008	C	-	W	T	U	Low

FUNCTION	OBJECT NUMBER	Name	Value	Length	Datapoint Type		Flags					Priority
					Data Type Name	DPT_ID	C	R	W	T	U	
4-way Louver3	45	Control_Louver 4-way-3 / 5 Pos	Thresholds: 0, 30, 50, 70, 90% ①Heat and FAN (F1-F5) F1:0-29% F2:30-49% F3:50-69% F4:70-89% F5:90-100% ②Cool and Dry (F1-F3) F1:0-29% F2:30-49% F3:50-100%	1 bit	percentage (0..100%)	DPT_5.001	C	-	W	T	U	Low
	46	Control_Louver 4-way-3 / 5 Pos	Position values: 1,2,3,4,5 ①Heat and FAN (F1-F5) F1:0-1 F2:2 F3:3 F4:4 F5:5 or more ②Cool and Dry (F1-F3) F1:0-1 F2:2 F3:3 or more	1 Byte	counter pulses (0..255)	DPT_5.010	C	-	W	T	U	Low
	47	Control_Louver 4-way-3 Stop	1-Stop	1 bit	boolean	DPT_1.002	C	-	W	T	U	Low
	48	Control_Louver 4-way-3 Swing	1-Swing	1 bit	boolean	DPT_1.002	C	-	W	T	U	Low
	49	Control_Louver 4-way-3 +/-	0-Decrease;1-Increase	1 bit	step	DPT_1.007	C	-	W	T	U	Low
	50	Control_Louver 4-way-3 +/-	0-Up;1-Down	1 bit	up/down	DPT_1.008	C	-	W	T	U	Low

FUNCTION	OBJECT NUMBER	Name	Value	Length	Datapoint Type		Flags					Priority
					Data Type Name	DPT_ID	C	R	W	T	U	
4-way Louver4	51	Control_Louver 4-way-4 / 5 Pos	Thresholds: 0, 30, 50, 70, 90% ①Heat and FAN (F1-F5) F1:0-29% F2:30-49% F3:50-69% F4:70-89% F5:90-100% ②Cool and Dry (F1-F3) F1:0-29% F2:30-49% F3:50-100%	1 bit	percentage (0..100%)	DPT_5.001	C	-	W	T	U	Low
	52	Control_Louver 4-way-4 / 5 Pos	Position values: 1,2,3,4,5 ①Heat and FAN (F1-F5) F1:0-1 F2:2 F3:3 F4:4 F5:5 or more ②Cool and Dry (F1-F3) F1:0-1 F2:2 F3:3 or more	1 Byte	counter pulses (0..255)	DPT_5.010	C	-	W	T	U	Low
	53	Control_Louver 4-way-4 Stop	1-Stop	1 bit	boolean	DPT_1.002	C	-	W	T	U	Low
	54	Control_Louver 4-way-4 Swing	1-Swing	1 bit	boolean	DPT_1.002	C	-	W	T	U	Low
	55	Control_Louver 4-way-4 +/-	0-Decrease;1-Increase	1 bit	step	DPT_1.007	C	-	W	T	U	Low
	56	Control_Louver 4-way-4 +/-	0-Up;1-Down	1 bit	up/down	DPT_1.008	C	-	W	T	U	Low

FUNCTION	OBJECT NUMBER	Name	Value	Length	Datapoint Type		Flags					Priority
					Data Type Name	DPT_ID	C	R	W	T	U	
Setpoint	57	Control_ Temperature Setting	°C	2 bytes	temperature (°C)	DPT_9.001	C	-	W	T	U	Low
	58	Control_ Temperature Setting +/-	0-Decrease;1-Increase	1 bit	step	DPT_1.007	C	-	W	-	-	Low
	59	Control_ Temperature Setting +/-	0-Up;1-Down	1 bit	up/down	DPT_1.008	C	-	W	-	-	Low
Dual Setpoint	60	Control_ AutoCooling Temperature Setting	°C	2 bytes	temperature (°C)	9.001	C	-	W	T	U	Low
	61	Control_ AutoCooling Temperature Setting +/-	0-Decrease;1-Increase	1 bit	step	DPT_1.007	C	-	W	-	-	Low
	62	Control_ AutoCooling Temperature Setting +/-	0-Up;1-Down	1 bit	up/down	DPT_1.008	C	-	W	-	-	Low
	63	Control_ AutoHeating Temperature Setting	°C	2 bytes	temperature (°C)	9.001	C	-	W	T	U	Low
	64	Control_ AutoHeating Temperature Setting +/-	0-Decrease;1-Increase	1 bit	step	DPT_1.007	C	-	W	-	-	Low
	65	Control_ AutoHeating Temperature Setting +/-	0-Up;1-Down	1 bit	up/down	DPT_1.008	C	-	W	-	-	Low
Permit Prohibit	66	Control_ Permit/Prohibit control of Remote Controller ALL	0-Permit;1-Prohibit	1 bit	boolean	DPT_1.002	C	-	W	T	U	Low
	67	Control_ Permit/Prohibit control of Remote Controller On/Off	0-Permit;1-Prohibit	1 bit	boolean	DPT_1.002	C	-	W	T	U	Low
	68	Control_ Permit/Prohibit control of Remote Controller Mode	0-Permit;1-Prohibit	1 bit	boolean	DPT_1.002	C	-	W	T	U	Low
	69	Control_ Permit/Prohibit control of Remote Controller Temperature Setting	0-Permit;1-Prohibit	1 bit	boolean	DPT_1.002	C	-	W	T	U	Low
	70	Control_ Permit/Prohibit control of Remote Controller FAN speed	0-Permit;1-Prohibit	1 bit	boolean	DPT_1.002	C	-	W	T	U	Low

FUNCTION	OBJECT NUMBER	Name	Value	Length	Datapoint Type		Flags					Priority
					Data Type Name	DPT_ID	C	R	W	T	U	
	71	Control_Permit/Prohibit control of Remote Controller Louver	0-Permit;1-Prohibit	1 bit	boolean	DPT_1.002	C	-	W	T	U	Low
Filter sign	72	Control_Reset Filter	1-Reset filter	1 bit	reset	DPT_1.015	C	-	W	T	U	Low
Save Operation	73	Control_Save Operation Normal Operation	1-Activate no save	1 bit	boolean	DPT_1.002	C	-	W	T	U	Low
	74	Control_Save Operation 100-50% Operation	1-Activate 1..49% save	1 bit	boolean	DPT_1.002	C	-	W	T	U	Low
	75	Control_Save Operation 50% Operation	1-Activate 50% save	1 bit	boolean	DPT_1.002	C	-	W	T	U	Low
	76	Control_Save Operation Thermo Off	1-Activate 100% save	1 bit	boolean	DPT_1.002	C	-	W	T	U	Low
Ventilation On/Off	77	Control_Ventilation On/Off	0-Off; 1-On	1 bit	switch	DPT_1.001	C	-	W	T	U	Low
Ventilation Mode	78	Control_Ventilation Mode Heat Exchange	1-Activate Ventilation Heat Exchange Mode	1 bit	boolean	DPT_1.002	C	-	W	T	U	Low
	79	Control_Ventilation Mode Bypass	1-Activate Ventilation Bypass Mode	1 bit	boolean	DPT_1.002	C	-	W	T	U	Low
	80	Control_Ventilation Mode Automatic	1-Activate Ventilation Automatic Mode	1 bit	boolean	DPT_1.002	C	-	W	T	U	Low
	81	Control_Ventilation Mode -/+	0-Decrease;1-Increase	1 bit	step	DPT_1.007	C	-	W	-	-	Low
	82	Control_Ventilation Mode +/-	0-Up;1-Down	1 bit	up/down	DPT_1.008	C	-	W	-	-	Low
Ventilation Volume	83	Control_Ventilation Air Volume Stop	1-Activate Ventilation air volume stop	1 bit	boolean	DPT_1.002	C	-	W	T	U	Low
	84	Control_Ventilation Air Volume H	1-Activate Ventilation air volume H	1 bit	boolean	DPT_1.002	C	-	W	T	U	Low
	85	Control_Ventilation Air Volume L	1-Activate Ventilation air volume L	1 bit	boolean	DPT_1.002	C	-	W	T	U	Low
	86	Control_Ventilation Air Volume Imbalance	1-Activate Ventilation air volume imbalance	1 bit	boolean	DPT_1.002	C	-	W	T	U	Low
	87	Control_Ventilation Air Volume -/+	0-Decrease;1-Increase	1 bit	step	DPT_1.007	C	-	W	-	-	Low

FUNCTION	OBJECT NUMBER	Name	Value	Length	Datapoint Type		Flags					Priority
					Data Type Name	DPT_ID	C	R	W	T	U	
	88	Control_ Ventilation Air Volume +/-	0-Up;1-Down	1 bit	up/down	DPT_1.008	C	-	W	-	-	Low
Soft Cooling	89	Control_ Soft Cooling	0-Off;1-On	1 bit	switch	DPT_1.001	C	-	W	T	U	Low

4.2 Status

FUNCTION	OBJECT NUMBER	Name	Value	Length	Datapoint Type		Flags					Priority
					Data Type Name	DPT_ID	C	R	W	T	U	
On/Off	90	Status_ On/Off	0-Off;1-On	1 bit	switch	DPT_1.001	C	R	-	T	-	Low
Mode	91	Status_ Mode	0-Auto;1-Heat;3-Cool;9-Fan;14-Dry	1 byte	HVAC control mode	DPT_20.10	C	R	-	T	-	Low
	92	Status_ Mode Cool/Heat	0-Cool;1-Heat	1 bit	cooling/heating	DPT_1.100	C	R	-	T	-	Low
	93	Status_ Mode Auto	1-AUTO mode is active	1 bit	boolean	DPT_1.002	C	R	-	T	-	Low
	94	Status_ Mode Heat	1-HEAT mode is active	1 bit	boolean	DPT_1.002	C	R	-	T	-	Low
	95	Status_ Mode Cool	1-COOL mode is active	1 bit	boolean	DPT_1.002	C	R	-	T	-	Low
	96	Status_ Mode Fan	1-FAN mode is active	1 bit	boolean	DPT_1.002	C	R	-	T	-	Low
	97	Status_ Mode Dry	1-DRY mode is active	1 bit	boolean	DPT_1.002	C	R	-	T	-	Low
	98	Status_ Mode Au-toHeat	1-AUTOHEAT mode is active	1 bit	boolean	DPT_1.002	C	R	-	T	-	Low
	99	Status_ Mode Au-toCool	1-AUTOCOOL mode is active	1 bit	boolean	DPT_1.002	C	R	-	T	-	Low
	100	Status_ Mode Text	ASCII String	14 bytes	Character String (ASCII)	DPT_16.00	C	R	-	T	-	Low
Fan	101	Status_ Fan Speed / N Speeds	100*n/N % ①3Fan Speed(L,H,HH) L :33% H :67% HH:100% ②5Fan Speed (L,L+,H,H+,HH) L :20% L+:40% H :60% H+:80% HH:100%	1 byte	percentage (0..100%)	DPT_5.001	C	R	-	T	-	Low
	102	Status_ Fan Speed / N Speeds	Speed values: 1...N	1 byte	counter pulses (0..255)	DPT_5.010	C	R	-	T	-	Low

FUNCTION	OBJECT NUMBER	Name	Value	Length	Datapoint Type		Flags					Priority
					Data Type Name	DPT_ID	C	R	W	T	U	
	103	Status_ Fan Speed Man/ Auto	0-Manual;1-Auto	1 bit	boolean	DPT_1.002	C	R	-	T	-	Low
	104	Status_ Fan Speed Stop	1-Fan Stop	1 bit	boolean	DPT_1.002	C	R	-	T	-	Low
	105	Status_ Fan Speed LL	1-Fan Extra Low	1 bit	boolean	DPT_1.002	C	R	-	T	-	Low
	106	Status_ Fan Speed 1	1-Fan in speed 1	1 bit	boolean	DPT_1.002	C	R	-	T	-	Low
	107	Status_ Fan Speed 2	1-Fan in speed 2	1 bit	boolean	DPT_1.002	C	R	-	T	-	Low
	108	Status_ Fan Speed 3	1-Fan in speed 3	1 bit	boolean	DPT_1.002	C	R	-	T	-	Low
	109	Status_ Fan Speed 4	1-Fan in speed 4	1 bit	boolean	DPT_1.002	C	R	-	T	-	Low
	110	Status_ Fan Speed 5	1-Fan in speed 5	1 bit	boolean	DPT_1.002	C	R	-	T	-	Low
	111	Status_ Fan Speed Text	ASCII String	14 bytes	Character String (ASCII)	DPT_16.00	C	R	-	T	-	Low
Louver	112	Status_ Louver / 5 Pos	20%, 40%, 60%, 80%, 100% F1:20% F2:40% F3:60% F4:80% F5:100%	1 byte	percentage (0..100%)	DPT_5.001	C	R	-	T	-	Low
	113	Status_ Louver / 5 Pos	Position values: 1,2,3,4,5 F1:1 F2:2 F3:3 F4:4 F5:5	1 byte	counter pulses (0..255)	DPT_5.010	C	R	-	T	-	Low
	114	Status_ Louver Stop	1-Louver Stop	1 bit	boolean	DPT_1.002	C	R	-	T	-	Low
	115	Status_ Louver Pos 1	1-Louver in Position 1	1 bit	boolean	DPT_1.002	C	R	-	T	-	Low
	116	Status_ Louver Pos 2	1-Louver in Position 2	1 bit	boolean	DPT_1.002	C	R	-	T	-	Low
	117	Status_ Louver Pos 3	1-Louver in Position 3	1 bit	boolean	DPT_1.002	C	R	-	T	-	Low
	118	Status_ Louver Pos 4	1-Louver in Position 4	1 bit	boolean	DPT_1.002	C	R	-	T	-	Low
	119	Status_ Louver Pos 5	1-Louver in Position 5	1 bit	boolean	DPT_1.002	C	R	-	T	-	Low
	120	Status_ Louver Swing	1-Louver Swing	1 bit	boolean	DPT_1.002	C	R	-	T	-	Low
	121	Status_ Louver Text	ASCII String	14 bytes	Character String (ASCII)	DPT_16.00	C	R	-	T	-	Low

FUNCTION	OBJECT NUMBER	Name	Value	Length	Datapoint Type		Flags					Priority
					Data Type Name	DPT_ID	C	R	W	T	U	
4-way Louver1	122	Status_ Louver 4-way-1 / 5 Pos	20%, 40%, 60%, 80%, 100% F1:20% F2:40% F3:60% F4:80% F5:100%	1 bit	boolean	DPT_5.001	C	R	-	T	-	Low
	123	Status_ Louver 4-way-1 / 5 Pos	Position values: 1,2,3,4,5 F1:1 F2:2 F3:3 F4:4 F5:5	1 byte	counter pulses (0..255)	DPT_5.010	C	R	-	T	-	Low
	124	Status_ Louver 4-way-1 Stop	1-Louver Stop	1 bit	boolean	DPT_1.002	C	R	-	T	-	Low
	125	Status_ Louver 4-way-1 Swing	1-Louver Swing	1 bit	boolean	DPT_1.002	C	R	-	T	-	Low
	126	Status_ Louver 4-way-1 Text	ASCII String	14 bytes	Character String (ASCII)	DPT_16.00	C	R	-	T	-	Low
4-way Louver2	127	Status_ Louver 4-way-2 / 5 Pos	20%, 40%, 60%, 80%, 100% F1:20% F2:40% F3:60% F4:80% F5:100%	1 bit	boolean	DPT_5.001	C	R	-	T	-	Low
	128	Status_ Louver 4-way-2 / 5 Pos	Position values: 1,2,3,4,5 F1:1 F2:2 F3:3 F4:4 F5:5	1 byte	counter pulses (0..255)	DPT_5.010	C	R	-	T	-	Low
	129	Status_ Louver 4-way-2 Stop	1-Louver Stop	1 bit	boolean	DPT_1.002	C	R	-	T	-	Low
	130	Status_ Louver 4-way-2 Swing	1-Louver Swing	1 bit	boolean	DPT_1.002	C	R	-	T	-	Low
	131	Status_ Louver 4-way-2 Text	ASCII String	14 bytes	Character String (ASCII)	DPT_16.00	C	R	-	T	-	Low

FUNCTION	OBJECT NUMBER	Name	Value	Length	Datapoint Type		Flags					Priority
					Data Type Name	DPT_ID	C	R	W	T	U	
4-way Louver3	132	Status_ Louver 4-way-3 / 5 Pos	20%, 40%, 60%, 80%, 100% F1:20% F2:40% F3:60% F4:80% F5:100%	1 bit	boolean	DPT_5.001	C	R	-	T	-	Low
	133	Status_ Louver 4-way-3 / 5 Pos	Position values: 1,2,3,4,5 F1:1 F2:2 F3:3 F4:4 F5:5	1 byte	counter pulses (0..255)	DPT_5.010	C	R	-	T	-	Low
	134	Status_ Louver 4-way-3 Stop	1-Louver Stop	1 bit	boolean	DPT_1.002	C	R	-	T	-	Low
	135	Status_ Louver 4-way-3 Swing	1-Louver Swing	1 bit	boolean	DPT_1.002	C	R	-	T	-	Low
	136	Status_ Louver 4-way-3 Text	ASCII String	14 bytes	Character String (ASCII)	DPT_16.00	C	R	-	T	-	Low
4-way Louver4	137	Status_ Louver 4-way-4 / 5 Pos	20%, 40%, 60%, 80%, 100% F1:20% F2:40% F3:60% F4:80% F5:100%	1 bit	boolean	DPT_5.001	C	R	-	T	-	Low
	138	Status_ Louver 4-way-4 / 5 Pos	Position values: 1,2,3,4,5 F1:1 F2:2 F3:3 F4:4 F5:5	1 byte	counter pulses (0..255)	DPT_5.010	C	R	-	T	-	Low
	139	Status_ Louver 4-way-4 Stop	1-Louver Stop	1 bit	boolean	DPT_1.002	C	R	-	T	-	Low
	140	Status_ Louver 4-way-4 Swing	1-Louver Swing	1 bit	boolean	DPT_1.002	C	R	-	T	-	Low
	141	Status_ Louver 4-way-4 Text	ASCII String	14 bytes	Character String (ASCII)	DPT_16.00	C	R	-	T	-	Low

FUNCTION	OBJECT NUMBER	Name	Value	Length	Datapoint Type		Flags					Priority
					Data Type Name	DPT_ID	C	R	W	T	U	
Setpoint	142	Status_ Temperature Setting	°C	2 bytes	temperature (°C)	DPT_9.001	C	R	-	T	-	Low
Dual Setpoint	143	Status_ AutoCool Temperature Setting	°C	2 bytes	temperature (°C)	DPT_9.001	C	R	-	T	-	Low
	144	Status_ AutoHeat Temperature Setting	°C	2 bytes	temperature (°C)	DPT_9.001	C	R	-	T	-	Low
TA	145	Status_ TA	°C	2 bytes	temperature (°C)	DPT_9.001	C	R	-	T	-	Low
Control Temp	146	Status_ Control Temperature	°C	2 bytes	temperature (°C)	DPT_9.001	C	R	-	T	-	Low
Permit Prohibit	147	Status_ Permit/Prohibit control of Remote Controller ALL	0-Permitted;1-Prohibited	1 bit	boolean	DPT_1.002	C	R	-	T	-	Low
	148	Status_ Permit/Prohibit control of Remote Controller On/Off	0-Permitted;1-Prohibited	1 bit	boolean	DPT_1.002	C	R	-	T	-	Low
	149	Status_ Permit/Prohibit control of Remote Controller Mode	0-Permitted;1-Prohibited	1 bit	boolean	DPT_1.002	C	R	-	T	-	Low
	150	Status_ Permit/Prohibit control of Remote Controller Temperature Setting	0-Permitted;1-Prohibited	1 bit	boolean	DPT_1.002	C	R	-	T	-	Low
	151	Status_ Permit/Prohibit control of Remote Controller FAN speed	0-Permitted;1-Prohibited	1 bit	boolean	DPT_1.002	C	R	-	T	-	Low
	152	Status_ Permit/Prohibit control of Remote Controller Louver	0-Permitted;1-Prohibited	1 bit	boolean	DPT_1.002	C	R	-	T	-	Low
Filter sign	153	Status_ Filter Status	0-No alarm;1-Alarm	1 bit	alarm	DPT_1.005	C	R	-	T	-	Low

FUNCTION	OBJECT NUMBER	Name	Value	Length	Datapoint Type		Flags					Priority
					Data Type Name	DPT_ID	C	R	W	T	U	
Alarm	154	Status_ Alarm	0-No alarm;1-Alarm	1 bit	alarm	DPT_1.005	C	R	-	T	-	Low
	155	Status_ Alarm Code	0-No error '-1'-communication error (*4) '-3'-paused '-4'-initialization (*3) '-5'-Low-power-consumption mode Any other, see manual "Check Code"	2 bytes	2-byte signed value	—	C	R	-	T	-	Low
	156	Status_ Alarm Text	ASCII String	14 bytes	Character String (ASCII)	DPT_16.00	C	R	-	T	-	Low
	157	Status_ Alarm Address Interface	0-Off; 1-On	1 bit	switch	DPT_1.001	C	R	-	T	-	Low
	158	Status_ Alarm Address RC	0-Off; 1-On	1 bit	switch	DPT_1.001	C	R	-	T	-	Low
	159	Status_ Alarm Address IU's	0-Off; 1-On	1 bit	switch	DPT_1.001	C	R	-	T	-	Low
Save Operation	160	Status_ Save Operation Normal Operation	1-No save is active	1 bit	boolean	DPT_1.002	C	R	-	T	-	Low
	161	Status_ Save Operation 100-50% Operation	1-1..49% save is active	1 bit	boolean	DPT_1.002	C	R	-	T	-	Low
	162	Status_ Save Operation 50% Operation	1-50% save is active	1 bit	boolean	DPT_1.002	C	R	-	T	-	Low
	163	Status_ Save Operation Thermo Off	1-100% save is active	1 bit	boolean	DPT_1.002	C	R	-	T	-	Low
Ventilation On/Off	164	Status_ Ventilation On/Off	0-Off; 1-On	1 bit	switch	DPT_1.001	C	R	-	T	-	Low
Ventilation Mode	165	Status_ Ventilation Mode Heat Exchange	1-Ventilation Heat Exchange Mode is active	1 bit	boolean	DPT_1.002	C	R	-	T	-	Low
	166	Status_ Ventilation Mode Bypass	1-Activate Ventilation Bypass Mode	1 bit	boolean	DPT_1.002	C	R	-	T	-	Low
	167	Status_ Ventilation Mode Automatic	1-Activate Ventilation Automatic Mode	1 bit	boolean	DPT_1.002	C	R	-	T	-	Low

FUNCTION	OBJECT NUMBER	Name	Value	Length	Datapoint Type		Flags					Priority
					Data Type Name	DPT_ID	C	R	W	T	U	
Ventilation Volume	168	Status_ Ventilation Air Volume Stop	1-Ventilation air volume stop is active	1 bit	boolean	DPT_1.002	C	R	-	T	-	Low
	169	Status_ Ventilation Air Volume H	1-Ventilation air volume H is active	1 bit	boolean	DPT_1.002	C	R	-	T	-	Low
	170	Status_ Ventilation Air Volume L	1-Ventilation air volume L is active	1 bit	boolean	DPT_1.002	C	R	-	T	-	Low
	171	Status_ Ventilation Air Volume Imbalance	1-Ventilation air volume imbalance is active	1 bit	boolean	DPT_1.002	C	R	-	T	-	Low
TF	172	Status_ TF	°C	2 bytes	temperature (°C)	DPT_9.001	C	R	-	T	-	Low
Function On/Off	173	Status_ Soft Cooling	0-Off; 1-On	1 bit	switch	DPT_1.001	C	R	-	T	-	Low
	174	Status_ Operation Standby	0-Off; 1-On	1 bit	switch	DPT_1.001	C	R	-	T	-	Low
	175	Status_ Heating Standby	0-Off; 1-On	1 bit	switch	DPT_1.001	C	R	-	T	-	Low
	176	Status_ Frost Protection Setting	0-Disable;1-Enable	1 bit	enable	DPT_1.003	C	R	-	T	-	Low
	177	Status_ Night Low Noise	0-Off; 1-On	1 bit	switch	DPT_1.001	C	R	-	T	-	Low
	178	Status_ Cleaning	0-Off; 1-On	1 bit	switch	DPT_1.001	C	R	-	T	-	Low
	179	Status_ Heat Exchanger Clean Operation	0-Off; 1-On	1 bit	switch	DPT_1.001	C	R	-	T	-	Low
	180	Status_ Frost Protection	0-Off; 1-On	1 bit	switch	DPT_1.001	C	R	-	T	-	Low
	181	Status_ Refrigerant Leakage	0-Off; 1-On	1 bit	switch	DPT_1.001	C	R	-	T	-	Low
	182	Status_ Energy Saving Operation	0-Off; 1-On	1 bit	switch	DPT_1.001	C	R	-	T	-	Low
	183	Status_ Demand Response	0-100%	1 byte	percentage (0..100%)	DPT_5.001	C	R	-	T	-	Low
	184	Status_ Multi Tenant Control	0-Off; 1-On	1 bit	switch	DPT_1.001	C	R	-	T	-	Low
	185	Status_ Night Purge	0-Off; 1-On	1 bit	switch	DPT_1.001	C	R	-	T	-	Low
186	Status_ 24 Hours Operation	0-Off; 1-On	1 bit	switch	DPT_1.001	C	R	-	T	-	Low	

FUNCTION	OBJECT NUMBER	Name	Value	Length	Datapoint Type		Flags					Priority
					Data Type Name	DPT_ID	C	R	W	T	U	
	187	Status_ Ventilation Standby	0-Off; 1-On	1 bit	switch	DPT_1.001	C	R	-	T	-	Low
Central Controll Address	188	Status_ Central Controll Address	0-255	1 byte	counter pulses (0..255)	DPT_5.010	C	R	-	T	-	Low
Indoor Unit Setting	189	Status_ Cooling Temp Upper Limit	°C	2 bytes	temperature (°C)	DPT_9.001	C	R	-	T	-	Low
	190	Status_ Cooling Temp Lower Limit	°C	2 bytes	temperature (°C)	DPT_9.001	C	R	-	T	-	Low
	191	Status_ Heating Temp Upper Limit	°C	2 bytes	temperature (°C)	DPT_9.001	C	R	-	T	-	Low
	192	Status_ Heating Temp Lower Limit	°C	2 bytes	temperature (°C)	DPT_9.001	C	R	-	T	-	Low
	193	Status_ Dry Temp Upper Limit	°C	2 bytes	temperature (°C)	DPT_9.001	C	R	-	T	-	Low
	194	Status_ Dry Temp Lower Limit	°C	2 bytes	temperature (°C)	DPT_9.001	C	R	-	T	-	Low
	195	Status_ AutoTemp Upper Limit	°C	2 bytes	temperature (°C)	DPT_9.001	C	R	-	T	-	Low
	196	Status_ AutoTemp Lower Limit	°C	2 bytes	temperature (°C)	DPT_9.001	C	R	-	T	-	Low
	197	Status_ Setting Permit Mode-Fan	0-Disable;1-Enable	1 bit	enable	DPT_1.003	C	R	-	T	-	Low
	198	Status_ Setting Permit Mode-Cooling	0-Disable;1-Enable	1 bit	enable	DPT_1.003	C	R	-	T	-	Low
	199	Status_ Setting Permit Mode-Dry	0-Disable;1-Enable	1 bit	enable	DPT_1.003	C	R	-	T	-	Low
	200	Status_ Setting Permit Mode-Heating	0-Disable;1-Enable	1 bit	enable	DPT_1.003	C	R	-	T	-	Low
	201	Status_ Setting Permit Mode-Auto	0-Disable;1-Enable	1 bit	enable	DPT_1.003	C	R	-	T	-	Low
202	Status_ Setting Fan Auto	0-Disable;1-Enable	1 bit	enable	DPT_1.003	C	R	-	T	-	Low	
203	Status_ Setting Fan LL	0-Disable;1-Enable	1 bit	enable	DPT_1.003	C	R	-	T	-	Low	

FUNCTION	OBJECT NUMBER	Name	Value	Length	Datapoint Type		Flags					Priority
					Data Type Name	DPT_ID	C	R	W	T	U	
	204	Status_ Setting Fan Speed Range	Num of Fan Speeds	1 byte	counter pulses (0..255)	DPT_5.010	C	R	-	T	-	Low
	205	Status_ Setting Louver	0-Disable;1-Enable	1 bit	enable	DPT_1.003	C	R	-	T	-	Low
	206	Status_ Setting Louver Num Ways	0-No ways; 1-1 way; 2-2 ways; 4-4 ways	1 byte	counter pulses (0..255)	DPT_5.010	C	R	-	T	-	Low
	207	Status_ Setting Ventilation	0-Disable;1-Enable	1 bit	enable	DPT_1.003	C	R	-	T	-	Low
	208	Status_ Setting Ventilation Heat Exchange Mode	0-Disable;1-Enable	1 bit	enable	DPT_1.003	C	R	-	T	-	Low
	209	Status_ Setting Ventilation Bypass Mode	0-Disable;1-Enable	1 bit	enable	DPT_1.003	C	R	-	T	-	Low
	210	Status_ Setting Ventilation Automatic Mode	0-Disable;1-Enable	1 bit	enable	DPT_1.003	C	R	-	T	-	Low
	211	Status_ Setting Ventilation Fan Speed Low	0-Disable;1-Enable	1 bit	enable	DPT_1.003	C	R	-	T	-	Low
	212	Status_ Setting Ventilation Fan Speed High	0-Disable;1-Enable	1 bit	enable	DPT_1.003	C	R	-	T	-	Low
	213	Status_ Setting Ventilation Fan Speed Unbalance	0-Disable;1-Enable	1 bit	enable	DPT_1.003	C	R	-	T	-	Low
	214	Status_ Setting Dual Setpoint Function	0-Disable;1-Enable	1 bit	enable	DPT_1.003	C	R	-	T	-	Low
	215	Status_ Setting Soft Cooling Function	0-Disable;1-Enable	1 bit	enable	DPT_1.003	C	R	-	T	-	Low
	216	Status_ Setting Fan 5 Speed Function	0-Disable;1-Enable	1 bit	enable	DPT_1.003	C	R	-	T	-	Low
	217	Status_ Setting Save Function	0-Disable;1-Enable	1 bit	enable	DPT_1.003	C	R	-	T	-	Low

- (*1) Temperature Read data 0x8000 means No Sensor or Sensor Error.
- (*2) While this product is being initialized or a communication error is present with the indoor unit, some objects are set to "0x7FFF".
- (*3) When DN Code Setting is performed from the "FIELD SETTING MENU" of the remote controller, this product also performs initialization.
- (*4) When communication is interrupted between this product and the indoor unit as well as the remote controller and the indoor unit for 3 minutes, it is assumed an indoor unit communication error. Performing DN Code Setting from the "FIELD SETTING MENU" of the remote controller may cause a communication error.

5. Precautions

5.1 *If the remote controller is not installed*

Use the ETS tool to set the parameter "GENERAL"- "This interface is header of the bus" to "Yes", and then supply power to the indoor unit.

Example

- Wired remote controller is not present or installed.
- Wireless remote controller receiver unit (sold separately) is not installed.
- Indoor unit is a wall-mounting type.

5.2 *"Permit/Prohibit of local" setting*

If the power of the indoor unit is interrupted after setting the parameter to "Prohibit of local", the indoor unit setting returns to "Permit of local" and it is necessary to set it to "Prohibit of local" again.

When the parameter "GENERAL" - "Disallow control from remote controller on initialization" is set to "Yes" by the ETS tool, the same Prohibit setting as the case where "1-Prohibit" is input to "Control_ Permit/Prohibit control of Remote Controller ALL" during initialization of this product is sent to the indoor unit.

"Control_ Permit/Prohibit control of Remote Controller ALL" setting

	0-When "Permit" is input	1-When "Prohibit" is input
Remote Controller On/Off	Permit	Prohibit
Remote Controller Mode	Permit	Prohibit
Remote Controller Temperature Setting	Permit	Prohibit
Remote Controller FAN speed	Permit	Prohibit
Remote Controller Louver	Permit	Prohibit

5.3 *Louver setting*

If the louver of the indoor unit is set from TCB-IFKX0TLR-E, the same louver setting is applied to both Header and Follower devices. For the 4-way louver, the same setting is applied to the 4-way louvers 1 to 4.

5.4 *4-way louver setting*

The 4-way louver setting is available when the indoor unit (Individual and Header) uses the 4-way louver. The Follower device cannot set the 4-way louver.

5.5 *Auto-cooling/Auto-heating setpoint*

If auto-cooling setpoint \geq auto-heating setpoint, the setting values of the auto-cooling setpoint and auto-heating setpoint are transmitted to the indoor unit. If auto-cooling setpoint $<$ auto-heating setpoint, the setting values are ignored.

5.6 *When alarm code remains at (-4)-initialization*

If communication with the outdoor unit is not available when power is supplied to the indoor unit, the alarm status of TCB-IFKX0TLR-E is "1-Alarm" and the alarm code may remain at "(-4)- initialization". Supply power to the outdoor unit.

5.7 Temperature setting unit of 1°C or 0.5°C (indoor unit)

(1) For 1°C unit

- Pressing +/- or +/- increase or decreases the temperature by 1°C.
- A decimal number input for the temperature is ignored.

(Example)

Input value	Set value for the indoor unit
24.1	24
24.2	24
24.3	24
24.4	24
24.5	24
24.6	24
24.7	24
24.8	24
24.9	24

(2) For 0.5°C unit

- Pressing +/- or +/- increase or decreases the temperature by 1°C.
- When a decimal number is input for the temperature, a value corresponding to it as listed in the table below is transmitted. Therefore, for 0.5°C unit, input 1°C- or 0.5°C-unit values.

(Example)

Input value	Set value for the indoor unit
24.1	24.0
24.2	24.0
24.3	24.5
24.4	24.5
24.5	24.5
24.6	24.5
24.7	24.5
24.8	25.0
24.9	25.0

5.8 Ventilation functions

Ventilation On/Off is available when the indoor unit has a ventilation fan, the indoor unit is a total enthalpy heat exchange or direction expansion type, the indoor Follower unit is a total enthalpy heat exchange or direction expansion type.

Ventilation mode and ventilation volume is available when the indoor unit is a total enthalpy heat exchange or direction expansion type, or the indoor Follower unit is a total enthalpy heat exchange or direction expansion type.

5.9 Fan speed status

When the fan speed of the indoor unit is changed to "Auto" or "Stop", the parameters No.101 "Status_ Fan Speed / N Speeds" and No.102 "Status_ Fan Speed / N Speeds" retain the values before change.

5.10 Louver status

When the louver of the indoor unit is changed to "Stop" or "Swing", the parameters No.112 "Status_ Louver / 5 Pos" and No.113 "Status_ Louver / 5 Pos" retain the values before change. This is also true for the louvers 4-way-1 to 4-way-4.

5.11 Total enthalpy heat exchange unit status

Since the total enthalpy heat exchange unit does not have the mode, fan speed, and louver settings, the mode, fan speed, and louver status settings are ignored.

6. Setting Using ETS Tool

This product is a KNX device that complies with the KNX standard, so configuration and commissioning can be performed with the ETS tool of KNX Association. Use the ETS4 or ETS5 version of the ETS tool.

6.1 How to obtain the ETS database

Download the ETS database from the following website.

http://www.toshiba-carrier.co.jp/global/appli/ets_db/download/index.htm

Database file for ETS5/4 BMS-IFKX0TLR-E_v1.0r.knxprod

NOTE

"_v1.0" of the database file name is the version number. This number may change.

6.2 ETS Parameters

Use the Parameter screen of the ETS tool to configure this product.

[GENERAL screen]

15.15.255 KNX Interface for Toshiba AC > GENERAL		
GENERAL	Download latest database entry for this product and its User Manual from:	<input type="text" value="http://www.toshiba-carrier.co.jp/global/appli/ets_db/c"/>
MODE	Send READs for objects on bus recovery (T & U flags must be active)	<input type="radio"/> No <input checked="" type="radio"/> Yes
FANSPEED	Delay before sending READs	<input type="text" value="10"/> [s]
LOUVER	This interface is header of the bus	<input checked="" type="radio"/> No <input type="radio"/> Yes
TEMPERATURE	Disallow control from remote controller on initialization	<input checked="" type="radio"/> No <input type="radio"/> Yes
OTHER	Enable "Permit/Prohibit Remote Controller" objects	<input checked="" type="radio"/> No <input type="radio"/> Yes
	Enable system configuration objects (status)	<input checked="" type="radio"/> No <input type="radio"/> Yes
	Enable use of objects for Filter (for Control and Status)	<input checked="" type="radio"/> No <input type="radio"/> Yes
	Enable object "Alarm Code [2byte]"	<input checked="" type="radio"/> No <input type="radio"/> Yes
	Enable object "Alarm Text [14byte]"	<input checked="" type="radio"/> No <input type="radio"/> Yes

[MODE screen]

15.15.255 KNX Interface for Toshiba AC > MODE	
GENERAL	Indoor unit has mode AUTO (see docum. for your indoor unit) <input type="radio"/> No <input checked="" type="radio"/> Yes
MODE	Indoor unit has mode HEAT (see docum. for your indoor unit) <input type="radio"/> No <input checked="" type="radio"/> Yes
FANSPEED	Indoor unit has mode COOL (see docum. for your indoor unit) <input type="radio"/> No <input checked="" type="radio"/> Yes
LOUVER	Indoor unit has mode FAN (see docum. for your indoor unit) <input type="radio"/> No <input checked="" type="radio"/> Yes
TEMPERATURE	Indoor unit has mode DRY (see docum. for your indoor unit) <input type="radio"/> No <input checked="" type="radio"/> Yes
OTHER	Enable "Mode Cool/Heat" objects (for Control and Status) <input type="radio"/> No <input checked="" type="radio"/> Yes Enable PID-Compat. Scaling Mode objects (for Control) <input type="radio"/> No <input checked="" type="radio"/> Yes Enable use of +/- object for Mode <input type="radio"/> No <input checked="" type="radio"/> Yes > DPT type for +/- Mode Object <input checked="" type="radio"/> 0-Decrease / 1-Increase [DPT_1.007] <input type="radio"/> 0-Up / 1-Down [DPT_1.008] Enable use of bit-type Mode objects (for Control) <input type="radio"/> No <input checked="" type="radio"/> Yes Enable use of bit-type Mode objects (for Status) <input type="radio"/> No <input checked="" type="radio"/> Yes Enable use of Text object for Mode <input type="radio"/> No <input checked="" type="radio"/> Yes ASCII strings shown in comm object "Status_Mode Text" <<14-byte string values >> ... when mode is AUTO mode AUTO ... when mode is HEAT mode HEAT ... when mode is COOL mode COOL ... when mode is FAN mode FAN ... when mode is DRY mode DRY

[FANSPEED screen]

15.15.255 KNX Interface for Toshiba AC > FANSPEED		
GENERAL	Num. of FanSpeeds Available	5
MODE	Indoor unit has AUTO fan speed (see docum. for your indoor unit)	<input type="radio"/> No <input checked="" type="radio"/> Yes
FANSPEED	Enable use of DPT_5001 for Fan Speed	<input type="radio"/> No <input checked="" type="radio"/> Yes
LOUVER	Enable use of DPT_5010 for Fan Speed	<input type="radio"/> No <input checked="" type="radio"/> Yes
TEMPERATURE	Enable use of +/- object for Fan Speed	<input type="radio"/> No <input checked="" type="radio"/> Yes
OTHER	> DPT type for +/- Fan Speed object	<input checked="" type="radio"/> 0-Decrease / 1-Increase [DPT_1.007] <input type="radio"/> 0-Up / 1-Down [DPT_1.008]
	> Does +/- sequence include fan speed AUTO?	<input type="radio"/> No <input checked="" type="radio"/> Yes
	> Rollover Speed at upper/lower limit (when controlling with +/- obj)	<input type="radio"/> No <input checked="" type="radio"/> Yes
	Enable "Fan Speed Man/Auto" objects (for Control and Status)	<input type="radio"/> No <input checked="" type="radio"/> Yes
	Enable use of bit-type Fan Speed objects (for Control)	<input type="radio"/> No <input checked="" type="radio"/> Yes
	Enable use of bit-type Fan Speed objects (for Status)	<input type="radio"/> No <input checked="" type="radio"/> Yes
	Enable use of Text object for Fan Speed	<input type="radio"/> No <input checked="" type="radio"/> Yes
	ASCII strings shown in comm object "Status_FanSpeed Text"	<<14-byte string values >>
	... when fan is AUTO	fan AUTO
	... when fan is STOP	fan STOP
	... when fan is LL	fan EXTRA LOW
	... when fan is SPEED 1	fan SPEED 1
	... when fan is SPEED 2	fan SPEED 2
	... when fan is SPEED 3	fan SPEED 3
	... when fan is SPEED 4	fan SPEED 4
	... when fan is SPEED 5	fan SPEED 5

[LOUVER screen]

15.15.255 KNX Interface for Toshiba AC > LOUVER		
GENERAL	Indoor unit has Louver (see docum. for your indoor unit)	<input type="radio"/> No <input checked="" type="radio"/> Yes
MODE	Num. Of Ways in Indoor Unit (see docum. for your indoor unit)	4 ways
FANSPEED	Indoor unit has Louver Positions (see docum. for your indoor unit)	<input type="radio"/> No <input checked="" type="radio"/> Yes
LOUVER	Available positions in Indoor Unit (see docum. for your indoor unit)	5
TEMPERATURE	Enable use of DPT_5001 for Louver	<input type="radio"/> No <input checked="" type="radio"/> Yes
OTHER	Enable use of DPT_5010 for Louver	<input type="radio"/> No <input checked="" type="radio"/> Yes
	Enable use of bit-type Louver objects (for Control)	<input type="radio"/> No <input checked="" type="radio"/> Yes
	Enable use of bit-type Louver objects (for Status)	<input type="radio"/> No <input checked="" type="radio"/> Yes
	Enable "Louver Swing" objects (for Control and Status)	<input type="radio"/> No <input checked="" type="radio"/> Yes
	Enable use of +/- object for Louver	<input type="radio"/> No <input checked="" type="radio"/> Yes
	> DPT type for +/- Louver object	<input checked="" type="radio"/> 0-Decrease / 1-Increase [DPT_1.007] <input type="radio"/> 0-Up / 1-Down [DPT_1.008]
	> Does +/- sequence include STOP Louver?	<input type="radio"/> No <input checked="" type="radio"/> Yes
	> Does +/- sequence include SWING Louver?	<input type="radio"/> No <input checked="" type="radio"/> Yes
	> Rolllover Louver at upper/lower limit (when controlling with +/- obj)	<input type="radio"/> No <input checked="" type="radio"/> Yes
	Enable use of Text object for Louver	<input type="radio"/> No <input checked="" type="radio"/> Yes
	ASCII strings shown in comm object "Status_ Louver Text"	<<14-byte string values >>
	... when louver is SWING	louver SWING
	... when louver is POSITION 1	louver POS 1
	... when louver is POSITION 2	louver POS 2
	... when louver is POSITION 3	louver POS 3
	... when louver is POSITION 4	louver POS 4
	... when louver is POSITION 5	louver POS 5
	... when louver is STOP	louver STOP

	... when louver 4-way-1 is SWING	louver SWING
	... when louver 4-way-1 is POSITION 1	louver POS 1
	... when louver 4-way-1 is POSITION 2	louver POS 2
	... when louver 4-way-1 is POSITION 3	louver POS 3
	... when louver 4-way-1 is POSITION 4	louver POS 4
	... when louver 4-way-1 is POSITION 5	louver POS 5
	... when louver 4-way-1 is STOP	louver STOP
	... when louver 4-way-2 is SWING	louver SWING
	... when louver 4-way-2 is POSITION 1	louver POS 1
	... when louver 4-way-2 is POSITION 2	louver POS 2
	... when louver 4-way-2 is POSITION 3	louver POS 3
	... when louver 4-way-2 is POSITION 4	louver POS 4
	... when louver 4-way-2 is POSITION 5	louver POS 5
	... when louver 4-way-2 is STOP	louver STOP

	... when louver 4-way-3 is SWING	louver SWING
	... when louver 4-way-3 is POSITION 1	louver POS 1
	... when louver 4-way-3 is POSITION 2	louver POS 2
	... when louver 4-way-3 is POSITION 3	louver POS 3
	... when louver 4-way-3 is POSITION 4	louver POS 4
	... when louver 4-way-3 is POSITION 5	louver POS 5
	... when louver 4-way-3 is STOP	louver STOP
	... when louver 4-way-4 is SWING	louver SWING
	... when louver 4-way-4 is POSITION 1	louver POS 1
	... when louver 4-way-4 is POSITION 2	louver POS 2
	... when louver 4-way-4 is POSITION 3	louver POS 3
	... when louver 4-way-4 is POSITION 4	louver POS 4
	... when louver 4-way-4 is POSITION 5	louver POS 5
	... when louver 4-way-4 is STOP	louver STOP
	Group Objects Parameter	

[TEMPERATURE screen]

15.15.255 KNX Interface for Toshiba AC > TEMPERATURE

GENERAL	Periodic sending of "Status_Temperature Setting" (in seconds; 0=No periodic sending)	0
MODE	Transmission of "Status_Control Temperature"	Only on change
FANSPEED	Transmission of "Status_TA"	Only on change
LOUVER	Enable use of +/- objs for Temperature Setting	<input type="radio"/> No <input checked="" type="radio"/> Yes
TEMPERATURE	> DPT type for +/- Temperature Setting objects	<input checked="" type="radio"/> 0-Decrease / 1-Increase [DPT_1.007] <input type="radio"/> 0-Up / 1-Down [DPT_1.008]
OTHER		

[OTHER screen]

15.15.255 KNX Interface for Toshiba AC > OTHER

GENERAL	Enable use of Soft Cooling Objects	<input type="radio"/> No <input checked="" type="radio"/> Yes
MODE	Enable use of Save Operation Objects	<input type="radio"/> No <input checked="" type="radio"/> Yes
FANSPEED	Enable use of Ventilation Objects	<input type="radio"/> No <input checked="" type="radio"/> Yes
LOUVER	> Enable use of +/- objects for Ventilation	<input type="radio"/> No <input checked="" type="radio"/> Yes
TEMPERATURE	> DPT type for +/- Ventilation objects	<input checked="" type="radio"/> 0-Decrease / 1-Increase [DPT_1.007] <input type="radio"/> 0-Up / 1-Down [DPT_1.008]
OTHER		

Setting item	Item No.	Item	Selection type	Additional object No. (*3)	Display condition of item	Default
GENERAL	1	Send READs for objects on bus recovery (T & U flags must be active)	Radio Button (No/Yes)			Yes
	2	Delay before sending READs	Set Number		Displayed when No.1 is "Yes"	10
	3	This interface is header of the bus (*1)	Radio Button (No/Yes)			No
	4	Disallow control from remote controller on initialization (*2)	Radio Button (No/Yes)			No
	5	Enable "Permit/Prohibit Remote controller" objects	Radio Button (No/Yes)	66-71, 147-152		Yes
	6	Enable system configuration objects (status)	Radio Button (No/Yes)	174-217		Yes
	7	Enable use of objects for Filter (for Control and Status)	Radio Button (No/Yes)	72, 153		Yes
	8	Enable object "Alarm Code [2byte]"	Radio Button (No/Yes)	155		Yes
	9	Enable object "Alarm Text [14byte]"	Radio Button (No/Yes)	156		Yes
MODE	10	Indoor unit has mode AUTO (see docum. For your indoor unit)	Radio Button (No/Yes)	5, 93, 98-99		Yes
	11	Indoor unit has mode HEAT (see docum. For your indoor unit)	Radio Button (No/Yes)	4, 6, 94		Yes
	12	Indoor unit has mode COOL (see docum. For your indoor unit)	Radio Button (No/Yes)	3, 7, 95		Yes
	13	Indoor unit has mode FAN (see docum. For your indoor unit)	Radio Button (No/Yes)	8, 96		Yes
	14	Indoor unit has mode DRY (see docum. For your indoor unit)	Radio Button (No/Yes)	9, 97		Yes
	15	Enable "Mode Cool/Heat" objects (for Control and Status)	Radio Button (No/Yes)	2, 92		Yes
	16	Enable PID-Compat. Scaling Mode objects (for Control)	Radio Button (No/Yes)	3, 4		Yes
	17	Enable use of +/- object for Mode	Radio Button (No/Yes)			Yes
	18	> DPT type for +/- Mode Object	Radio Button (DPT_1.007/ DPT_1.008)	10 or 11	Displayed when No.17 is "Yes"	0-Decrease
	19	Enable use of bit-type Mode objects (for Control)	Radio Button (No/Yes)	5-9		Yes

Setting item	Item No.	Item	Selection type	Additional object No. (*3)	Display condition of item	Default
	20	Enable use of bit-type Mode objects (for Status)	Radio Button (No/Yes)	93-99		Yes
	21	Enable use of Text object for Mode	Radio Button (No/Yes)	100		Yes
	22	... when mode is AUTO	Text BOX		Displayed when No.10 and No.21 are "Yes"	mode AUTO
	23	... when mode is HEAT	Text BOX		Displayed when No.21 is "Yes"	mode HEAT
	24	... when mode is COOL	Text BOX		Same as above	mode COOL
	25	... when mode is FAN	Text BOX		Same as above	mode FAN
	26	... when mode is DRY	Text BOX		Same as above	mode DRY
FANSPEED	27	Num. of FanSpeeds Available	Set Number (1-5)	16-19, 107-110		5
	28	Indoor unit has AUTO fan speed (see docum. For your indoor unit)	Radio Button (No/Yes)			Yes
	29	Enable use of DPT_5001 for Fan Speed	Radio Button (No/Yes)	12, 101		Yes
	30	Enable use of DPT_5010 for Fan Speed	Radio Button (No/Yes)	13, 102		Yes
	31	Enable use of +/- object for Fan Speed	Radio Button (No/Yes)			Yes
	32	> DPT type for +/- Fan Speed object	Radio Button (DPT_1.007/ DPT_1.008)	20 or 21	Displayed when No.31 is "Yes"	0-Decrease
	33	> Does +/- sequence include fan speed AUTO?	Radio Button (No/Yes)		Displayed when No.31 and No.28 are "Yes"	Yes
	34	> Rollover Speed at upper/lower limit (when controlling with +/- obj)	Radio Button (No/Yes)		Displayed when No.31 is "Yes"	Yes
	35	Enable "Fan Speed Man/ Auto" objects (for Control and Status)	Radio Button (No/Yes)	14, 103		Yes
	36	Enable use of bit-type Fan Speed objects (for Control)	Radio Button (No/Yes)	15-19		Yes
	37	Enable use of bit-type Fan Speed objects (for Status)	Radio Button (No/Yes)	106-110		Yes
	38	Enable use of Text object for Fan Speed	Radio Button (No/Yes)	111		Yes
	39	... when fan is AUTO	Text BOX		Displayed when No.31 and No.38 are "Yes"	fan AUTO
	40	... when fan is STOP	Text BOX		Displayed when No.38 is "Yes"	fan STOP
	41	... when fan is LL	Text BOX		Same as above	fan EXTRA LOW
	42	... when fan is SPEED 1	Text BOX		Same as above	fan SPEED 1

Setting item	Item No.	Item	Selection type	Additional object No. (*3)	Display condition of item	Default
	43	... when fan is SPEED 2	Text BOX		Displayed when No.27 is 2 or more and No.38 is "Yes"	fan SPEED 2
	44	... when fan is SPEED 3	Text BOX		Displayed when No.27 is 3 or more and No.38 is "Yes"	fan SPEED 3
	45	... when fan is SPEED 4	Text BOX		Displayed when No.27 is 4 or more and No.38 is "Yes"	fan SPEED 4
	46	... when fan is SPEED 5	Text BOX		Displayed when No.27 is 5 and No.38 is "Yes"	fan SPEED 5
LOUVER	47	Indoor unit has Louver (see docum. for your indoor unit)	Radio Button (No/Yes)	22-55, 112-141		Yes
	48	Num. Of Ways in Indoor Unit (see docum. for your indoor unit)	Pull-Down Menu (No ways/1 way/ 2 ways/4 ways)	[33, 35-37, 122, 124-126], [39, 41-43, 127, 129-131], [45, 47-49, 51, 53-55, 132, 134-137, 139-141]		4 way
	49	Indoor unit has Louver Positions (see docum. for your indoor unit)	Radio Button (No/Yes)	22, 25-29, 33, 39, 45, 51, 112, 115-119, 122, 127, 132, 137	Displayed when No.47 is "Yes"	Yes
	50	Available positions in Indoor Unit (see docum. for your indoor unit)	Set number (fixed to "5")		Displayed when No.47 is "Yes"	5
	51	Enable use of DPT_5001 for Louver	Radio Button (No/Yes)	22, 33, 39, 45, 51, 112, 122, 127, 132, 137		Yes
	52	Enable use of DPT 5010 for Louver	Radio Button (No/Yes)	23, 34, 40, 46, 52, 113, 123, 128, 133, 138		Yes
	53	Enable use of bit-type Louver objects (for Control)	Radio Button (No/Yes)	25-29	Displayed when No.47 is "Yes"	Yes
	54	Enable use of bit-type Louver objects (for Status)	Radio Button (No/Yes)	115-119	Displayed when No.47 is "Yes"	Yes
	55	Enable "Louver Swing" objects (for Control and Status)	Radio Button (No/Yes)			Yes
	56	Enable use of +/- object for Louver	Radio Button (No/Yes)		Displayed when No.47 is "Yes"	Yes
	57	> DPT type for +/- Louver object	Radio Button (DPT_1.007/ DPT_1.008)	[31, 37, 43, 49, 55] or [32, 38, 44, 50, 56]	Displayed when No.56 is "Yes"	0-Decrease
	58	> Does +/- sequence include STOP Louver?	Radio Button (No/Yes)		Displayed when No.47 and No.56 are "Yes"	Yes

Setting item	Item No.	Item	Selection type	Additional object No. (*3)	Display condition of item	Default
	59	> Does +/- sequence include SWING Louver?	Radio Button (No/Yes)		Same as above	Yes
	60	> Rollover Louver at upper/lower limit (when controlling with +/- obj)	Radio Button (No/Yes)		Same as above	Yes
	61	Enable use of Text object for Louver	Radio Button (No/Yes)	121, 126, 131, 136, 141	Displayed when No.47 is "Yes"	Yes
	62	... when louver is SWING	Text BOX		Displayed when No.47 and No.61 are "Yes"	louver SWING
	63	... when louver is POSITION 1	Text BOX		Same as above	louver POS 1
	64	... when louver is POSITION 2	Text BOX		Same as above	louver POS 2
	65	... when louver is POSITION 3	Text BOX		Same as above	louver POS 3
	66	... when louver is POSITION 4	Text BOX		Same as above	louver POS 4
	67	... when louver is POSITION 5	Text BOX		Same as above	louver POS 5
	68	... when louver is STOP	Text BOX		Same as above	louver STOP
	69	... when louver 4-way-1 is SWING	Text BOX		Displayed when No.47 and No.61 are "Yes" and No.47 is 1 way or more	louver SWING
	70	... when louver 4-way-1 is POSITION 1	Text BOX		Same as above	louver POS 1
	71	... when louver 4-way-1 is POSITION 2	Text BOX		Same as above	louver POS 2
	72	... when louver 4-way-1 is POSITION 3	Text BOX		Same as above	louver POS 3
	73	... when louver 4-way-1 is POSITION 4	Text BOX		Same as above	louver POS 4
	74	... when louver 4-way-1 is POSITION 5	Text BOX		Same as above	louver POS 5
	75	... when louver 4-way-1 is STOP	Text BOX		Same as above	louver STOP
	76	... when louver 4-way-2 is SWING	Text BOX		Displayed when No.47 and No.61 are "Yes" and No.47 is 2 ways or more	louver SWING
	77	... when louver 4-way-2 is POSITION 1	Text BOX		Same as above	louver POS 1
	78	... when louver 4-way-2 is POSITION 2	Text BOX		Same as above	louver POS 2
	79	... when louver 4-way-2 is POSITION 3	Text BOX		Same as above	louver POS 3
	80	... when louver 4-way-2 is POSITION 4	Text BOX		Same as above	louver POS 4
	81	... when louver 4-way-2 is POSITION 5	Text BOX		Same as above	louver POS 5

Setting item	Item No.	Item	Selection type	Additional object No. (*3)	Display condition of item	Default
	82	... when louver 4-way-2 is STOP	Text BOX		Same as above	louver STOP
	83	... when louver 4-way-3 is SWING	Text BOX		Displayed when No.47 and No.61 are "Yes" and No.47 is 4 ways or more	louver SWING
	84	... when louver 4-way-3 is POSITION 1	Text BOX		Same as above	louver POS 1
	85	... when louver 4-way-3 is POSITION 2	Text BOX		Same as above	louver POS 2
	86	... when louver 4-way-3 is POSITION 3	Text BOX		Same as above	louver POS 3
	87	... when louver 4-way-3 is POSITION 4	Text BOX		Same as above	louver POS 4
	88	... when louver 4-way-3 is POSITION 5	Text BOX		Same as above	louver POS 5
	89	... when louver 4-way-3 is STOP	Text BOX		Same as above	louver STOP
	90	... when louver 4-way-4 is SWING	Text BOX		Displayed when No.47 and No.61 are "Yes" and No.47 is 4 ways or more	louver SWING
	91	... when louver 4-way-4 is POSITION 1	Text BOX		Same as above	louver POS 1
	92	... when louver 4-way-4 is POSITION 2	Text BOX		Same as above	louver POS 2
	93	... when louver 4-way-4 is POSITION 3	Text BOX		Same as above	louver POS 3
	94	... when louver 4-way-4 is POSITION 4	Text BOX		Same as above	louver POS 4
	95	... when louver 4-way-4 is POSITION 5	Text BOX		Same as above	louver POS 5
	96	... when louver 4-way-4 is STOP	Text BOX		Same as above	louver STOP
TEMPER- ATURE	97	Periodic sending of "Status_ Temperature Setting" (in seconds; 0=No periodic sending)	Set Number			0
	98	Transmission of "Status_ Control Temperature"	Pull-Down Menu (Only cyclically/ Only on change/ Cyclically and on change)			Only on change
	99	> "Status_ Control Temperature" periodic sending time (in sec)	Set Number (1-255)		Displayed when No.98 is "Only cyclically" or "Cyclically and on change"	Only on change
	100	Transmission of "Status_ TA"	Pull-Down Menu (Only cyclically/ Only on change/ Cyclically and on change)			Yes

Setting item	Item No.	Item	Selection type	Additional object No. (*3)	Display condition of item	Default
	101	> "Status_ TA" periodic sending time (in sec)	Set Number (1-255)		Displayed when No.100 is "Only cyclically" or "Cyclically and on change"	180
	102	Enable use of +/- objs for Temperature Setting	Radio Button (No/Yes)			Yes
	103	> DPT type for +/- Temperature Setting objects	Radio Button (DPT_1.007/ DPT_1.008)	[58, 61, 64] or [59, 62, 65]	Displayed when No.102 is "Yes"	0-Decrease
OTHER	104	Enable use of Soft Cooling Objects	Radio Button (No/Yes)	89, 173		Yes
	105	Enable use of Save Operation Objects	Radio Button (No/Yes)	73-76, 160-163		Yes
	106	Enable use of Ventilation Objects	Radio Button (No/Yes)	77-80, 83-86, 164-171		Yes
	107	> Enable use of +/- objects for Ventilation	Radio Button (No/Yes)		Displayed when No.106 is "Yes"	Yes
	108	> DPT type for +/- Ventilation objects	Radio Button (DPT_1.007/ DPT_1.008)	[81, 87], [82, 88]	Displayed when No.106 and No.107 are "Yes"	0-Decrease

(*1) Set this parameter to "Yes" when the remote controller is not used. This product reads the status of the indoor unit on behalf of the remote controller.

(*2) When set to "Yes", the same Prohibit setting as the case where "1-Prohibit" is input to "Control_ Permit/Prohibit control of Remote Controller ALL" during initialization of this product is sent to the indoor unit.

(*3) The object may not be displayed until multiple parameter settings are changed.

(Example) To add the objects No. 5, 9, 98, and 99 by setting the parameter No.10 "Indoor unit has mode AUTO" to "Yes", it is also necessary to set the parameter No.19 "Enable use of bit-type Mode objects (for Control)" and parameter No.20 "Enable use of bit-type Mode objects (for Status)" to "Yes".

7. Check Code

Check code		Alarm Unit	Alarm Description
Hexadecimal Number	Remote Controller Display		
00	A00	-	No error
01	A01	Indoor unit	Flow switch operation error
02	A02	Indoor unit	Water temperature decrease error
04	A04	Indoor unit	Activation of water heat exchanger frost protection
06	A06	Indoor unit	Ignition failed
1B	A27	Indoor unit	Abnormal increase at temperature sensor for refrigerant heating outlet
1C	A28	Indoor unit	Other thermal component error
25	C05	-	Sending error in TCC-LINK central control device
26	C06	-	Receiving error in TCC-LINK central control device
2C	C12	-	Batch alarm of general-purpose interface
2F	C15	-	Error codes for thermal storage unit
41	E01	Remote controller	Communication error between indoor and remote controller
42	E02	Remote controller	Sending error of remote controller
43	E03	Indoor unit	Communication error between indoor and remote controller
44	E04	Indoor unit	Communication circuit error between indoor and outdoor
46	E06	Outdoor unit	Decrease of No. of indoor units
47	E07	Outdoor unit	Communication circuit error between indoor/outdoor
48	E08	Indoor unit Outdoor unit	Duplicated indoor addresses
49	E09	Remote controller	Duplicated Header remote controllers
4A	E10	Indoor unit	Communication error between indoor P.C.board
4B	E11	Outdoor unit	Communication error at optional PCB in indoor unit
4C	E12	Outdoor unit	Automatic address start error
4D	E13	Indoor unit	Periodic communication error (DX-kit -> 0 - 10 V I/F) at indoor unit <-> 0 - 10 V interface
4E	E14	Indoor unit	Periodic communication error between indoor unit and 0 to 10 V interface
4F	E15	Outdoor unit	No indoor automatic address
50	E16	Outdoor unit	Capacity over/No. of connected indoor units
51	E17	Indoor unit	Bad reception from flow selector (FS) unit
52	E18	Indoor unit	Communication error between indoor header and follower units
53	E19	Outdoor unit	Outdoor header units quantity error
54	E20	Outdoor unit	Other line connected during automatic address
55	E21	Outdoor unit	Header thermal storage units quantity error
56	E22	Outdoor unit	Decrease of No. of thermal storage units
57	E23	Outdoor unit	Sending error in communication between outdoor units
59	E25	Outdoor unit	Duplicated follower outdoor address
5A	E26	Outdoor unit	Decrease of No. of connected outdoor units
5C	E28	Outdoor unit	Follower outdoor unit error
5F	E31	Outdoor unit	IPDU communication error

Check code		Alarm Unit	Alarm Description
Hexadecimal Number	Remote Controller Display		
61	F01	Indoor unit	Indoor TCJ sensor error
62	F02	Indoor unit	Indoor TC2 sensor error
63	F03	Indoor unit	Indoor heat exchanger temperature sensor (TC1) error
64	F04	Outdoor unit	TD1 sensor error
65	F05	Outdoor unit	TD2 sensor error
66	F06	Outdoor unit	TE1/TE2 sensor error
67	F07	Outdoor unit	TL sensor error
68	F08	Outdoor unit	TO sensor error
69	F09	Outdoor unit	TG sensor error
6A	F10	Indoor unit	Indoor TA/TSA sensor error
6B	F11	Indoor unit	Indoor TF/TFA sensor error
6C	F12	Outdoor unit	TS1 sensor error
6D	F13	Outdoor unit	TH sensor error
6E	F14	Outdoor unit	TR sensor error
6F	F15	Outdoor unit	Outdoor temp. sensor misconnection (TE1/TL)
70	F16	Outdoor unit	Outdoor pressure sensor misconnection (Pd/Ps)
71	F17	Indoor unit	TOA sensor error
72	F18	Indoor unit	TRA sensor error
73	F19	Indoor unit	Indoor heat exchanger temperature sensor (TF) error
74	F20	Outdoor unit	PL (fluid piping pressure) sensor error
76	F22	Outdoor unit	TD3 sensor error
77	F23	Outdoor unit	Ps sensor error
78	F24	Outdoor unit	Pd sensor error
79	F25	Indoor unit	Indoor heat exchanger temperature sensor (TA) error
7A	F26	Indoor unit	Indoor heat exchanger temperature sensor (TC2) error
7D	F29	Indoor unit	Indoor other error
7E	F30	Indoor unit	Occupancy sensor error
7F	F31	Outdoor unit	Outdoor EEPROM error
81	H01	IPDU	Compressor break down
82	H02	IPDU	Magnet switch / Overcurrent operation / Compressor error
83	H03	IPDU	Current detection circuit error
84	H04	Outdoor unit	Comp-1 case thermo operation
85	H05	Outdoor unit	Outdoor temp. sensor misconnection (TD1)
86	H06	Outdoor unit	Low pressure protective operation
87	H07	Outdoor unit	Low oil level protection
88	H08	Outdoor unit	Oil level temp. sensor error
8E	H14	Outdoor unit	Comp-2 case thermo operation
8F	H15	Outdoor unit	Outdoor temp. sensor misconnection (TD2)
90	H16	Outdoor unit	Oil level circuit / Magnet switch / Overcurrent error
99	H25	Outdoor unit	Outdoor temp. sensor misconnection (TD3)
A1	J01	Indoor unit	Flow selector (FS) unit has bad reception from indoor unit (main unit)
A3	J03	Indoor unit	Flow selector (FS) unit is duplicated

Check code		Alarm Unit	Alarm Description
Hexadecimal Number	Remote Controller Display		
AA	J10	Indoor unit	Float SW operating at flow selector (FS) unit
AB	J11	Indoor unit	TCS sensor error in flow selector (FS) unit
AC	J12	Indoor unit	Sensor 2 error in flow selector (FS) unit
C2	L02	Indoor unit	Inconsistency error of outdoor units
C3	L03	Indoor unit	Duplicated indoor header units
C4	L04	Outdoor unit	Duplicated outdoor line address
C5	L05	Outdoor unit	Duplicated indoor units with priority
C6	L06	Outdoor unit	Duplicated indoor units with priority
C7	L07	Indoor unit	Group line in individual indoor unit
C8	L08	Indoor unit	Indoor group/Address unset
C9	L09	Indoor unit	Indoor capacity unset
CA	L10	Outdoor unit	Outdoor capacity unset
CC	L12	Indoor unit	Flow selector system error
D1	L17	Outdoor unit	Inconsistency error of outdoor units
D2	L18	Indoor unit	FS unit error
D4	L20	Indoor unit	Duplicated central control addresses
D5	L21	Indoor unit	200 V applied voltage error
D6	L22	Indoor unit	There are units in the group that do not support DX-KIT.
D7	L23	Outdoor unit	Setting abnormality
D8	L24	Indoor unit	Flow selector unit is set incorrectly
DA	L26	Indoor unit	Over No. of conneced thermal strage units
DB	L27	Indoor unit	Thermal storage units quantity error
DC	L28	Outdoor unit	Maximum number of outdoor units exceeded
DD	L29	Outdoor unit	No. of IPDU error
DE	L30	Indoor unit	Auxiliary interlock in indoor unit
DF	L31	Outdoor unit	IC error
E1	P01	Indoor unit	Indoor fan motor error
E2	P02	Indoor unit	Boost circuit error
E3	P03	Outdoor unit	Discharge temp. TD1 error
E4	P04	IPDU	High-pressure switch detection error
E5	P05	Outdoor unit	Phase-missing detection / Phase order error
E7	P07	Outdoor unit IPDU	Heat sink overheat error
E8	P08	Indoor unit	Intake air temperature error
EA	P10	Indoor unit	Indoor overflow error
EC	P12	Indoor unit	Indoor fan motor error
ED	P13	Outdoor unit	Outdoor liquid back detection error
EF	P15	Outdoor unit	Gas leak detection
F1	P17	Outdoor unit	Discharge temp. TD2 error
F2	P18	Outdoor unit	Discharge temp. TD3 error
F3	P19	Outdoor unit	4-way valve inverse error
F4	P20	Outdoor unit	High-pressure inverse error
F6	P22	IPDU	Outdoor fan IPDU error

Check code		Alarm Unit	Alarm Description
Hexadecimal Number	Remote Controller Display		
FA	P26	IPDU	G-Tr short circuit protection error
FD	P29	IPDU	Comp position detection circuit error
FE	P30	Indoor unit	Group terminal unit error
FF	P31	Indoor unit	Follower indoor unit error (Group error)
FFFF(-1)	-	I/F	I/F Error in the communication of BMS-IFKX0TLR-E device with the Indoor unit
FFFF(-2)	-	I/F	The BMS-IFKX0TLR-E has temporarily stopped communicating because the indoor unit or wired remote controller transmitted the system stop command.
FFFF(-4)	-	I/F	The BMS-IFKX0TLR-E is performing the initialization process.
FFFF(-5)	-	I/F	The BMS-IFKX0TLR-E has stopped communicating because the indoor unit switched to the low-power-consumption mode.

In case you detect an error code not listed, contact your nearest Toshiba technical support service.

TOSHIBA CARRIER EUROPE S.A.S

Route de Thil 01120 Montluel France